



# CHEMISTRY



**Graduate Program**  
**2023-2024**



Dear Prospective Graduate Student:

We are thrilled for your interest in our graduate program in the Department of Chemistry at Michigan State University. We offer the opportunity for you to embark on an exciting and transformative journey in our vibrant community of scholars, researchers, and educators, dedicated to pushing the boundaries of chemical knowledge and innovation.

As Chair, I take immense pride in our diverse and inclusive environment that fosters creativity, critical thinking, and collaboration. We offer research opportunities at the frontiers of chemistry and allied fields with mentorship by faculty experts and access to state-of-the-art facilities that provide outstanding opportunities for scientific growth.

The table on pages 16-17 outlines an impressive range of science covered by our faculty that enables our students to address global problems including those that connect to energy, sustainability, the environment and health. Active student groups such as the Chemistry Graduate Student Organization and Women in Chemistry additionally support professional and personal growth during our students' graduate school journey. Our goal is to educate the next generation of scientists to prepare them for the diverse range of careers that a PhD in Chemistry leads to.

Beyond this brochure, please check out our website and Twitter feed for recent highlights from our vibrant MSU Chemistry community. We appreciate your interest and hope that you reach out to us to learn more!

With best wishes,

A handwritten signature in black ink that reads "Timothy H. Warren".

Timothy H. Warren  
Rosenberg Professor of Chemistry and Chair  
Web: [www.chemistry.msu.edu](http://www.chemistry.msu.edu)  
Twitter: [@MSUChem](https://twitter.com/MSUChem)

# **CHEMISTRY GRADUATE BROCHURE 2023 - 2024**

## **Table of Contents**

Letter from the Chair . . . . .	Inside Front Over
Welcome . . . . .	page 4
The Department of Chemistry. . . . .	pages 5-6
The Chemistry Graduate Program. . . . .	pages 7-10
Graduate Student Life. . . . .	pages 11-12
Graduate Student Organizations. . . . .	pages 13-14
After Graduation. . . . .	page 15
Chemistry Research Faculty. . . . .	pages 16-61
Admission to Graduate Study. . . . .	page 62
Michigan State University. . . . .	pages 63-66
The Lansing Area. . . . .	page 67
In Closing. . . . .	page 68
MSU Campus Map. . . . .	Inside Back Cover
Lansing Area Map. . . . .	Outside Back Cover

### **Chemistry Graduate Office**

320 Chemistry Building  
Michigan State University  
East Lansing, MI 48824  
(517) 353-1092  
fax: (517) 353-1793

[graduateoffice@chemistry.msu.edu](mailto:graduateoffice@chemistry.msu.edu)

<http://www.chemistry.msu.edu>

# WELCOME

*to our Graduate Program brochure! We appreciate you considering the pursuit of a graduate degree in Chemistry at MSU, and we'd like to introduce you to our faculty, give you an overview of some of the broad-based cutting-edge scientific research that they and their graduate students are performing here at Michigan State University every day, and provide a brief description of our graduate program. We'll also give you a glimpse of MSU's beautiful 5,200+ acre campus, and describe a little of mid-Michigan life in the greater Lansing area.*

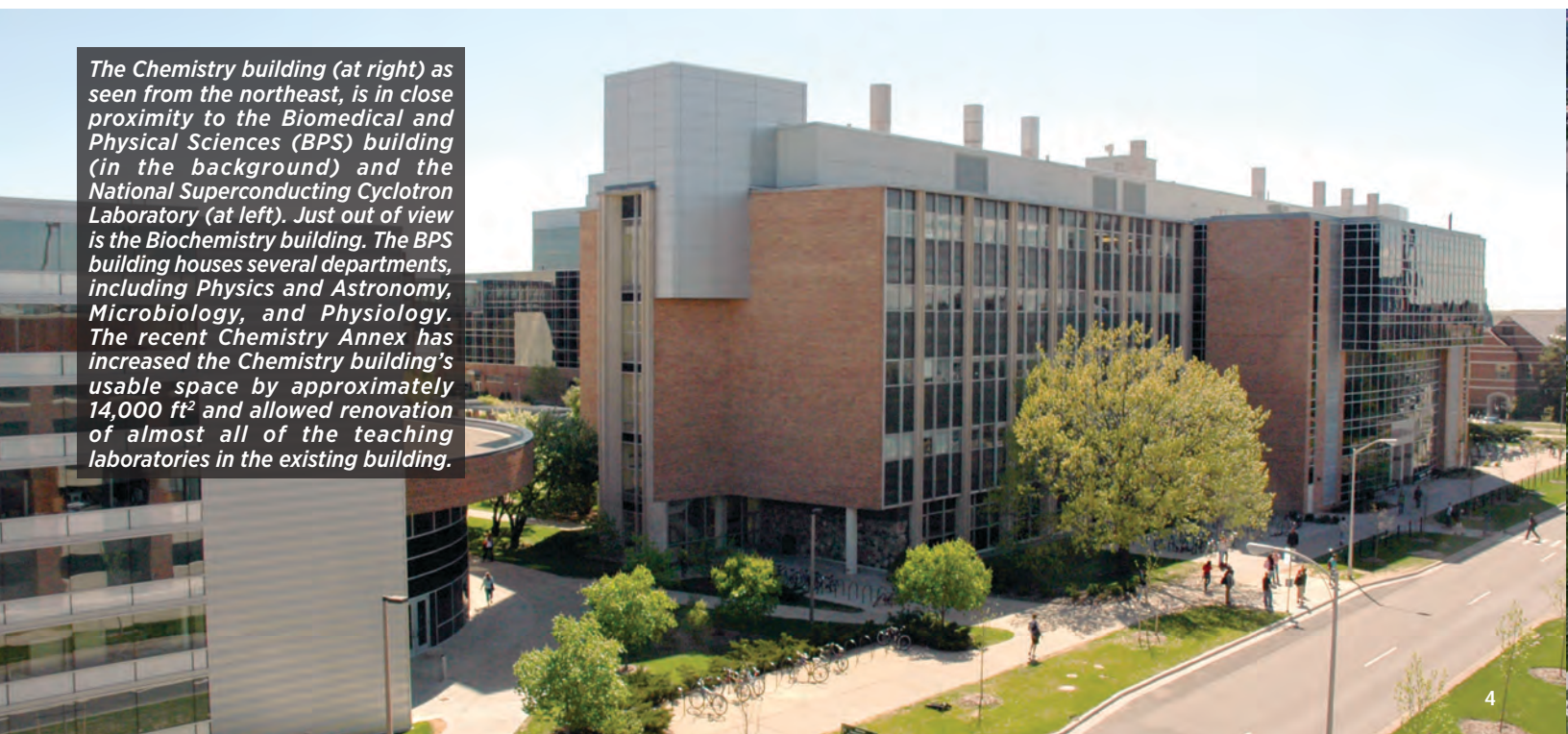
As our understanding of the workings of nature expands with the advancement of scientific knowledge and technology, the science of Chemistry, which lies at the center of many of the universe's mysteries, today is growing and changing at an unprecedented rate. MSU's Department of Chemistry has nonetheless consistently managed to stay at the forefront in chemistry research and teaching. We have done this by evolving and transforming as the science changes: through established faculty members developing and expanding their research interests to encompass the new challenges presented by the expanding frontier of knowledge; by hiring new faculty to broaden and enhance the capabilities of the department; and by changing course curricula, developing new teaching methods and techniques, and creating new courses to cover the ever-increasing knowledge base, while at the same time maintaining an academic program rooted in the basics of the discipline. Achieving these tasks is both challenging and exciting, and we invite you to join us in our ever-changing exploration at the forefront of chemistry research.

In the pages that follow, we can only give you only the broadest overview of the Chemistry Department, its faculty and their research interests, and what it's like to be a graduate student in Chemistry at MSU. You may have questions and concerns which are not met by the information found herein, and we encourage you to access our website or contact the Chemistry Graduate Office staff who will be happy to answer your questions directly. The contact information can be found on the Table of Contents page at the front of this brochure. We also encourage you to contact faculty members directly if you have questions or interest in their particular research. Their contact information may be found on the pages in the Research Interest section beginning on page 12.

We hope you will choose the MSU Department of Chemistry for pursuing your graduate education. It can be your stepping-stone to a successful career in Chemistry, as it has been for many others! 🍀



*The Chemistry building (at right) as seen from the northeast, is in close proximity to the Biomedical and Physical Sciences (BPS) building (in the background) and the National Superconducting Cyclotron Laboratory (at left). Just out of view is the Biochemistry building. The BPS building houses several departments, including Physics and Astronomy, Microbiology, and Physiology. The recent Chemistry Annex has increased the Chemistry building's usable space by approximately 14,000 ft<sup>2</sup> and allowed renovation of almost all of the teaching laboratories in the existing building.*



# THE DEPARTMENT

*of Chemistry occupies an air-conditioned building with 280,000 ft<sup>2</sup> of floor space distributed over five main floors, two basements, a penthouse complex, an office annex and a lecture-hall wing. Approximately 60% is devoted to research laboratories, instrument facilities, and supporting shops. All graduate students have 24-hour access to the building, their research laboratories and offices, and the computer rooms.*

The Chemistry Department moved into its current building when its construction was completed in 1964. At that time it was a state-of-the-art chemistry teaching and research facility. In the late 1990s the building underwent a large scale \$11 million renovation, and was later further improved in another \$12 million renovation to preserve that status. In April 2005, the State of Michigan funded a \$17.1 million addition to the Chemistry Building to accommodate our expansion and enhance our efforts in both graduate and undergraduate education. Construction of this annex was completed in Fall 2007, along with the expansion and renovation of all the chemistry teaching laboratories. Recently, the construction of a new \$72.5 million, 117,000 sq. ft. STEM teaching building which is nearly completed will allow moving most of the service-course teaching labs out of the Chemistry building, allowing for an increase in research lab space. This new STEM building is now completed. These updates provide for current state-of-the-art research and teaching facilities that allow the continued pursuit of our world-class research and teaching programs. Such costly investments by the University in the infrastructure of our Department reflect the high

level of support and respect that the Chemistry Program commands from MSU's administration.

## Research Facilities

Individual research laboratories typically have a substantial collection of supplies and equipment, including spectroscopic and structural analysis tools. Increasingly, however, modern research in Chemistry requires access to expensive state-of-the-art equipment, making it necessary to purchase such items on a shared basis and to provide staff for operation and maintenance. Facilities to pursue research in emerging areas of Chemistry are present in the Chemistry Building and are accessible to all graduate students:

Located in the Chemistry building, the Max T. Rogers NMR Facility provides fourteen high-field Bruker/Varian/Agilent NMR spectrometers with proton resonance frequencies ranging from 300 to 800 MHz. These include three 300 MHz instruments for routine studies, three 400 MHz NMR spectrometers for solid-state experiments including spinning speeds up to 60 kHz, two 500 MHz spectrometers for routine and advanced experiments, two fully

automated 500 MHz spectrometers equipped each with 96 sample robotic autosamplers, and a 600 MHz instrument for biomolecular and advanced small molecule work.

In early 2021, the NMR facility completed major room renovations to three labs and extensive upgrades to the research instruments. The new Bruker instruments include a 500 MHz spectrometer with a Prodigy BBO cryoprobe and a reaction monitoring accessory, a 600 MHz system with Prodigy TCI cryoprobe, a 800 MHz system with a helium TCI cryoprobe and fast-MAS and E-free solid-state NMR capabilities, and two 400 MHz solid-state NMR systems optimized for bio-solids including E-free, fast-MAS, and HR-MAS probes. The new 500, 600, and 800 MHz systems are equipped with autosamplers, with the latter two having cooled sample racks. The existing and new cutting-edge NMR capabilities at the Max T. Rogers NMR Facility demonstrate Michigan State University's commitment to supporting world-class research.

Since mass spectrometry is an indispensable tool in many research areas, Department researchers have easy access to twelve mass spectrometers



*An artist's rendering of the new MSU STEM teaching building, which was completed for Fall 2021.*

at the MSU Mass Spectrometry and Metabolomics Core (<https://rtsf.natsci.msu.edu/mass-spectrometry/>), located in the adjacent Biochemistry Building. The Core offers a variety of GC/MS, LC/MS/MS, UPLC/MS and MALDI mass spectrometers with an assortment of inlets and ionization methods, and functions as an open access laboratory. Students are encouraged to become trained instrument users; training includes discussions of theory and operation of Core instruments; following training, users enjoy 24/7 access using a Google Calendar reservation system. Recent Chemistry researchers have used these instruments for low- and high-resolution (accurate mass) analyses of synthetic compounds, quantitative analyses, and compound localization using mass spectrometry imaging. Facility staff are available to provide expert consultation regarding method development and data interpretation, and perform sample analyses upon request. Mass spectrometers can also be found in many individual research laboratories.

The Chemistry Department X-ray Facility was awarded (2019) an MRI-NSF grant for a dual microfocus source with a HYPIX Detector, which allows for rapid shutterless operation. In February of 2020, a new Rigaku Synergy S Diffractometer with dual source wavelength for single crystal x-ray diffraction was installed. This gives MSU the latest technology for



single crystal structural analysis. The University continues to provide access to the APS Synchrotron through LSCAT for protein crystallography and other X-ray diffraction needs. The department also houses a routine powder X-ray diffractometer and an X-ray fluorescence spectrometer for qualitative and semi-quantitative analyses. Graduate students may request hands-on training in the use of these instruments, which allows them to gain valuable experience and expertise in X-ray technologies.

In addition to these major instrument facilities in the Department, conveniently-located instrument rooms house liquid and gas chromatographic equipment, UV-VIS, FTIR, FT-MS, and fluorescence and Raman spectrometers. Elemental analysis via x-ray fluorescence, AA, and ICP are also available in the Chemistry Building.

The Chemistry Department operates well-equipped shops for the design and fabrication of unique and custom instrumentation and apparatus, and the repair of existing equipment required for research and teaching. The Machine Shop and the Glassblowing Facility are staffed by experienced professionals who are a vital component of the research performed at MSU. If you need something but can't buy it anywhere, it can likely be constructed with facilities in our Department.

### IT Facilities

The University provides access to supercomputers in the MSU High Performance Computer Center, and has 50 microcomputer and PC workstation laboratories around Campus, including a PC laboratory here in the Chemistry Building.

A 10 Gb/s fiber-optic network connects nearly all the buildings on campus; the Chemistry Building is internally networked by a twisted-pair wired LAN operating at 100 Mb/s which connects to the rest of campus through the 10 Gb/s fiber-optic backbone. The building also has WiFi connectivity throughout the entire building. MSU's campus is connected to the Internet through two dedicated 10 Gb/s links.

### Academic and Technical Staff

The Chemistry Department's technical staff assist in the execution of research and teaching by faculty and graduate students, and they do so extremely well. During their stay, most graduate students find that many of these people become integral parts of their education and research programs. In addition to the administrative and secretarial staff, we owe much to the dedication and outstanding work of the following academic and technical support staff:

#### Academic Specialists/Lecturers:

- Dr. Ardeshir Azadnia,  
*Organic Labs Coordinator*
- Dr. Brittany Busby  
*General Chemistry & Organic Lab Co-Coordinator*
- Dr. Virginia Cangelosi,
- Dr. Johanna Herman  
*General Chemistry Lab Co-Coordinator*
- Dr. Krystyna Kijewska
- Dr. Sheba Onchiri
- Dr. Amy Pollock,  
*Director of General Chemistry*
- Dr. Fangyi Shen
- Dr. Chrysoula Vasileiou
- Dr. Veronica Zhang

#### Computing and Information Technology:

- Mr. Chris Pfeffer
- Mr. Paul Reed

#### Max T. Rogers NMR Facility:

- Dr. Daniel Holmes
- Dr. Li Xie

#### X-ray Crystallography Facility:

- Dr. Richard J. Staples

#### Scientific Glassblowing Facility:

- Mr. Scott Bankroff,  
*Master Glassblower*

#### Machine Shop:

- Mr. Glenn Wesley

# THE GRADUATE PROGRAM

structure that applies to all students working toward their Ph.D. in

Chemistry is summarized below. Complete requirements for specific programs are available from the Chemistry Graduate Office, or in our on-line graduate student handbook "Chemistry Graduate Program Guide", available at <https://www.chemistry.msu.edu/graduate-program/current-students/graduate-program-guide/>.

## Financial Support

Essentially every Chemistry graduate student is provided financial support while pursuing their graduate degree. There are two types of support typically available: Teaching Assistantships (TAs), and Research Assistantships (RAs). Because the Chemistry Department provides chemistry courses to service a large number of students in many other disciplines (e.g., Engineering, Biology or Physics majors), our need for TAs is always great.

First-year graduate student TAs typically serve as instructors in recitations or lab sections in the lower undergraduate courses, while TAs who are further along in their graduate education typically serve in upper-level undergraduate courses and even graduate-level courses. However, the Chemistry Faculty are very aggressive in pursuing research grant support, so quite often their students are paid from these grants and serve as RAs instead, and are paid to perform research. RAs are not required to teach.

In the Fall of 2022, incoming first-year graduate students received annual stipends of \$27,348.00. Furthermore, Graduate Assistants (both TAs and RAs) are provided with health insurance, a tuition waiver of up to nine credits for each of the Fall and Spring semesters and up to five credits for the Summer semester (the normal full course load for Chemistry Graduate Students is six credits per semester), and a waiver of the matriculation fees each semester. These fringe benefits are substantial, totaling over \$15,000 per year for an out-of-state student. These assistantship stipends are automatically increased in the second year, and for 2023-24, the increase for second year students was to \$28,902.71 annually. (The Chemistry Department has historically supported Ph.D. candidates in good standing for a period of up to 5 years to allow for successful completion of their degree requirements.) We expect these values to be increased for the coming 2024-25 academic year.

Most students are appointed as TAs when they first arrive, and are assigned a faculty member as their initial advisor until they formally join a research group. This

occurs in their first year, and thereafter the remainder of their graduate career typically consists of a combination of TA and RA appointments, where the distribution of time spent as TA or RA depends on the student's ability, the individual research group, and availability of research funds.

In addition to TA and RA support, several types of Graduate Fellowships are also available. Historically, the high quality of Chemistry Graduate Students has allowed them to compete successfully for first-year Fellowships from the College of Natural Science and the University. The Graduate School at MSU is dedicated to a diverse educational community through Fellowship programs as well. Students and faculty routinely work together to secure National Fellowships from organizations such as the American Chemical Society, the National Science Foundation, the National Institutes of Health, and the Department of Homeland Security.

## Research Advisor Selection

Our Ph.D. program is designed to encourage students to get involved in their research quickly. New graduate students are expected to interview faculty and select a Research Advisor in their first semester, so they can begin their dissertation research project by the beginning of their second semester. By the end of their second semester, each student, in consultation with their Research Advisor, suggests three additional Faculty to serve with their Research Advisor as a Guidance Committee for their Ph.D. degree.

## Examinations

All entering students take Placement Examinations that test their basic skills at the undergraduate level in analytical, inorganic, organic, and physical chemistry. These exams aid us in identifying any inadequacies that exist in a student's technical background. Based on their outcome, courses and/or TA assignments are prescribed for the student as necessary, to ensure that the tools they need to successfully complete a graduate research program are in place.

The Comprehensive Exam requirement in Chemistry at Michigan State University serves as a structure to guide the student in progress toward their PhD. It has a written and an oral component. In their second semester in the Program, the student prepares a brief written statement of the research they will be doing in the summer following their first year. This document is reviewed by the student's guidance committee and the student's progress is evaluated in the fall of their second year. This evaluation is intended to guide the student in the preparation of their written report for their second year oral exam. The written document is submitted to the student's guidance committee two weeks prior to their oral exam, in the Spring semester of the second year. The purposes of both the written and oral components of this exam are to evaluate the candidate's knowledge of the field and relevant literature, their research progress to date, and their potential to develop into independent scientists.

## Language Requirement

While we believe that mastery of a second language is an important aspect of any education, and we strongly encourage all students to give serious consideration to the study of an additional language, there is no formal language requirement in the Graduate Program in Chemistry.

## Seminar

Each Ph.D. candidate is required to give two seminars—one in their second year, and another before graduating. Each week throughout the year, public seminars in each of the four areas are presented by graduate students. These seminars are a vital component of our Ph.D. program, and provide essential educational opportunities to both the speakers and their audiences.

## Course Requirements

As part of their education, graduate students are required to take at least six graduate-level courses. Depending on the student's research interests and prior training, some of these courses may be in other departments such as

Biochemistry, Chemical Engineering, Physics, or Environmental Toxicology. There are no core-course requirements. Each student works in consultation with their Advisor and Guidance Committee to establish personalized course work requirements. In this way, each student can tailor the appropriate balance between focused course work in a single area and the breadth of their overall graduate education.

### Research

Performing research at the forefront of science and developing the ability to think critically about complex problems are the essence of the Ph.D. in Chemistry. Examinations, seminars, and course work are all designed to prepare the student for research.

Descriptive titles of our Faculty's research interests (research which is carried out mainly by graduate students) are listed on pages 12 and 13, and more detailed descriptions of their research are given on subsequent pages. Selection of a Research Advisor normally includes selection of a research topic at the same time.

In addition to the research carried out in the Chemistry Department, there are a number of centers and programs on campus that provide research opportunities and financial support to graduate students in Chemistry. Groups of faculty on campus have created a number of programs to bring together researchers from different departments who share common interests. Frequently, the grants they secure provide for student support. In some cases, student participation in such programs is rather informal; while in other cases, students become a part of both the department and the program, satisfying course work and research requirements in each. Some examples of such entities which are currently active on campus include the Biotechnology Training Program, the Institute for Integrative Toxicology, the Center for Biological Modeling, the Center for Microbial Ecology, and the Center for Structural Biology. Such programs allow students in the Chemistry Department to pursue a variety of interdisciplinary research projects that involve scientists in other departments. In addition to these formal programs, faculty in Chemistry collaborate on research projects with many other departments and colleges, and some Chemistry Faculty hold joint appointments in other departments.

### Dissertation and Final Defense

The independent research and creative components of each student's research program are described in a written dissertation. This original contribution to the body of knowledge in the Chemical Sciences is defended by the candidate before the student's Guidance Committee. A portion of this examination is open to the public.

### Graduate Courses

We believe that our graduate course offerings are unique, and afford our students the opportunity of obtaining an outstanding education. Included in our catalog are several graduate laboratory courses such as **CEM 834-Advanced Analytical Chemistry**. Another important aspect of our program are Special Topics Courses. One way that students can learn about a research area is by joining a professor's research program; a second way is by taking an advanced Special Topics course given by a faculty member on their research area. By having the faculty offer in-depth courses in their areas of expertise, students can master several new and exciting areas of chemical research as represented in our Department. 📍



*Chemistry graduate student Benjamin Klahr in Prof. Hamann's group measures the photoelectrochemical efficiency of a thin-film electrode their group has designed.*



**The following graduate-level courses are currently offered by the Chemistry Department:**

- 811 Advanced Inorganic Chemistry I**  
*Fall. 3 credits.*  
Principles of chemical bonding, electronic structure, and reaction mechanisms of main group and transition metal compounds. Concepts of group theory.
- 812 Advanced Inorganic Chemistry II**  
*Spring. 3 credits.*  
Descriptive chemistry of inorganic compounds. Emphasis on synthesis, structure, and reactivity patterns of coordination, organometallic, and solid state compounds of transition metals and main group elements.
- 820 Organometallic Chemistry**  
*Spring. 3 credits.*  
Organometallic functional groups. Principles of electronic structure, and bonding in organometallic species will be related to reactivity patterns in common systems. Preparation of complexes with applications to catalytic and stoichiometric organic syntheses.
- 832 Mass Spectrometry**  
*Spring. 3 credits.*  
Instrumentation of mass spectrometry. Interpreting mass spectra of organic and inorganic molecules. Applications to analysis of large molecules and chromatography.
- 834 Advanced Analytical Chemistry I**  
*Fall. 3 credits.*  
Basic electronics and data acquisition/analysis, electrochemistry, and statistics for chemists.
- 835 Advanced Analytical Chemistry II**  
*Fall. 3 credits.*  
Separations, molecular spectroscopy, and mass spectrometry.
- 836 Separation Science**  
*Spring of odd-numbered years. 3 credits.*  
Physical and chemical principles of separations, column technology, and instrumentation for gas, liquid, and supercritical fluid chromatography.
- 837 Electroanalytical Chemistry**  
*Spring of even-numbered years. 3 credits.*  
Modern electroanalytical chemistry. Theory and applications to chemical and biological problems. Coulometry, voltammetry, ion-selective potentiometry and other electrochemical techniques.
- 845 Structure and Spectroscopy of Organic Compounds**  
*Fall. 3 credits.*  
Structural and stereochemical principles in organic chemistry. Applications of spectroscopic methods, especially nuclear magnetic resonance, static and dynamic aspects of stereochemistry. Spectroscopy in structure determination.
- 850 Intermediate Organic Chemistry**  
*Fall. 3 credits*  
Traditional and modern basic reaction mechanisms and principles and their synthetic applications.
- 851 Advanced Organic Chemistry**  
*Spring. 3 credits.*  
Structure, reactivity, and methods. Acid-base reactions, substitution, addition, elimination, and pericyclic processes. Major organic intermediates related to simple bonding theory, kinetics, and thermodynamics.
- 852 Methods of Organic Synthesis**  
*Spring. 3 credits*  
Principal reactions leading to carbon-carbon bond formation and functional group transformations. Strategies and methods of organic synthesis.
- 881 Atomic and Molecular Structure**  
*Fall. 3 credits.*  
Postulates of quantum mechanics, analytical solutions of the Schrödinger equation, theoretical descriptions of chemical bonding, spectroscopy, statistical mechanics, and statistical thermodynamics.
- 882 Kinetics and Spectroscopic Methods**  
*Spring. 3 credits.*  
Rate equations and mechanisms of chemical reactions: reaction rate theory, kinetic theory of gases, photochemistry. Spectroscopic methods, and applications of spectroscopy in reaction kinetics.
- 883 Computational Quantum Chemistry**  
*Fall. 3 credits.*  
Computational methods in determining electronic energy levels, equilibrium nuclear configurations, and other molecular properties.
- 888 Computational Chemistry**  
*Spring. 3 credits.*  
Computational approaches to molecular problems. Use of ab initio and semi-empirical electronic structure, molecular mechanics and molecular dynamics software.
- 890 Chemical Problems and Reports**  
*Fall, Spring, Summer. 1 to 6 credits.*  
Investigation and report of a non-thesis problem in chemistry.  
Sec. 001 – Faculty Seminar Series  
Sec. 002 – Second Year Oral  
Sec. 003 – Graded Research  
Sec. 004 – Summer Area Seminars/Special Topics
- 899 Master's Thesis Research**  
*Fall, Spring, Summer. 1 to 20 credits.*
- 913 Selected Topics in Inorganic Chemistry**  
*Fall, Spring. 1 to 3 credits.*  
Chemistry of metal-metal bonds and clusters, organometallic chemistry, layered oxides, and complex layered oxides. Photochemistry. Solid state chemistry and applications of quantum mechanics.
- 918 Inorganic Chemistry Seminar**  
*Fall, Spring. 1 credit.*  
Advances in inorganic chemistry reported by graduate students.
- 924 Selected Topics in Analytical Chemistry**  
*Fall, Spring. 2 to 3 credits.*  
Advanced computer techniques, surface chemistry, analytical chemistry of polymers, or statistics for chemists.
- 938 Analytical Chemistry Seminar**  
*Fall, Spring. 1 credit.*  
Advances in analytical chemistry reported by graduate students, faculty and guest lecturers.
- 956 Selected Topics in Organic Chemistry**  
*Fall, Spring. 1 to 3 credits.*  
Heterocyclic and organometallic chemistry, natural products, photochemistry, free radicals, or reaction mechanisms.
- 958 Organic Chemistry Seminar**  
*Fall, Spring. 1 credit.*  
Advances in organic chemistry reported by graduate students.
- 971 Emerging Topics in Chemistry**  
*Fall, Spring. 1 to 3 credits.*  
Discussion of a research topic of emerging interest in chemistry. Preparation of a proposal for funding of research.
- 987 Selected Topics in Physical Chemistry I**  
*Fall. 1 to 3 credits.*  
Topics such as kinetics and photochemistry, macromolecular and surface chemistry, molecular spectroscopy, electric and magnetic properties of matter, or applications of statistical mechanics to chemical problems.
- 988 Selected Topics in Physical Chemistry II**  
*Spring. 1 to 3 credits.*  
Topics such as analysis and interpretation of molecular spectra, advanced molecular structure theory, magnetic resonance, X-rays and crystal structure, scientific analysis of vacuum systems, or problems in statistical mechanics.

**991 Quantum Chemistry & Statistical Thermodynamics I**

*Fall. 3 credits.*

Principles and applications of quantum chemistry. Partition functions, spectroscopic measurements, and thermodynamic applications.

**992 Quantum Chemistry & Statistical Thermodynamics II**

*Spring. 3 credits.*

Analytical and numerical methods for solving quantum chemical problems. Statistical mechanics of solids and liquids.

**993 Advanced Topics in Quantum Chemistry**

*Spring of odd-numbered years.*

*3 credits.*

Spectroscopic theory, properties, of atoms and molecules in electric and magnetic fields, intermolecular forces. Many-body theory, molecular electronic structure, solid state chemistry, or molecular reaction dynamics.

**994 Advanced Topics in Statistical Mechanics**

*Spring of even-numbered years.*

*3 credits.*

Non-equilibrium statistical mechanics and thermodynamics. Correlation functions and spectroscopy, light scattering, magnetic relaxation, transport properties of fluids and gases, or statistical mechanics of chemical reactions.

**995 Nuclear Chemistry Seminar**

*Fall, Spring. 1 credit.*

Advances in nuclear chemistry reported by graduate students, faculty, and guest lecturers.

**998 Physical Chemistry Seminar**


*Fall, Spring. 1 credit.*

Advances in physical chemistry reported by graduate students.

**999 Doctoral Dissertation Research**

*Fall, Spring, Summer.*

*1 to 20 credits.* ♡



*MSU's campus is spectacularly beautiful in autumn. (Can you find the heart?)*

# GRADUATE STUDENT LIFE

*can be challenging, but it is also rewarding. While some students who come to MSU anticipate being overwhelmed by the more than 50,000 students and thousands of faculty and staff on campus, graduate students in Chemistry quickly settle in to the friendly atmosphere that our Department provides.*

In a typical year, approximately 40 new graduate students begin the Graduate Program in Chemistry. When they arrive, they are each assigned to a faculty advisor in their chosen area of interest, and provided with desk space in a research lab. In this way, first year graduate students quickly get to know the faculty and other more established graduate students, accelerating their integration into the Department. By the end of their first semester, the new students are expected to choose their permanent research advisors who then provide office space in their own research laboratories. With ~200 graduate students currently distributed among our approximately 40 faculty members, the average research group's size is around 5 students. Since multiple research projects are usually underway in every faculty member's group, students do not typically encounter situations where a large number of researchers are working on small aspects of a single large project. In many cases, a graduate student and their advisor are the sole researchers working on a particular

project. Our Department's high faculty-to-graduate student ratio allows for individual interactions between advisor and student on a very frequent if not daily basis.

As discussed previously, graduate students are supported as teaching assistants (TAs) or research assistants (RAs). When students are assigned a teaching assistantship, there are often many TA positions available, and students have the opportunity to state the teaching assignment that they prefer — such as laboratory instructor or recitation instructor. During the summer semester a smaller number of courses are offered, and fewer TA positions are available. Most students are supported in the summer either as a Graduate Research Assistant or as a Student Research Assistant, allowing them to concentrate full-time on their research. Support during Summer is normally provided by research grants. Our Department is committed to providing uninterrupted support for all students in good standing for a period of up to

five years, and we expect to do so in the future, as long as current financial conditions continue.

The graduate student experience in Chemistry begins with graduate class work, and an introduction to chemical research through interactions with the faculty, senior graduate students and postdoctoral fellows. As a new student's research skills mature, they develop into fully contributing members of the scientific community and help advance the forefront of knowledge in the Chemical Sciences.

In addition to these roles, graduate students are also vital participants in the Department and the University. Graduate students elect members to serve on Departmental decision-making committees such as the Educational Policies Committee, the Advisory Committee, and the Undergraduate Chemistry and Lab Committee. Graduate students may also serve on University-wide Committees. The Council of Graduate Students (COGS) has



**Professor Xuefei Huang and Ph.D. student Zahara Rashidjahanaba working in the Huang Group Lab.**

traditionally played a strong leadership role on campus. It has worked with the University to negotiate tuition waivers, health insurance and other benefits for graduate students.

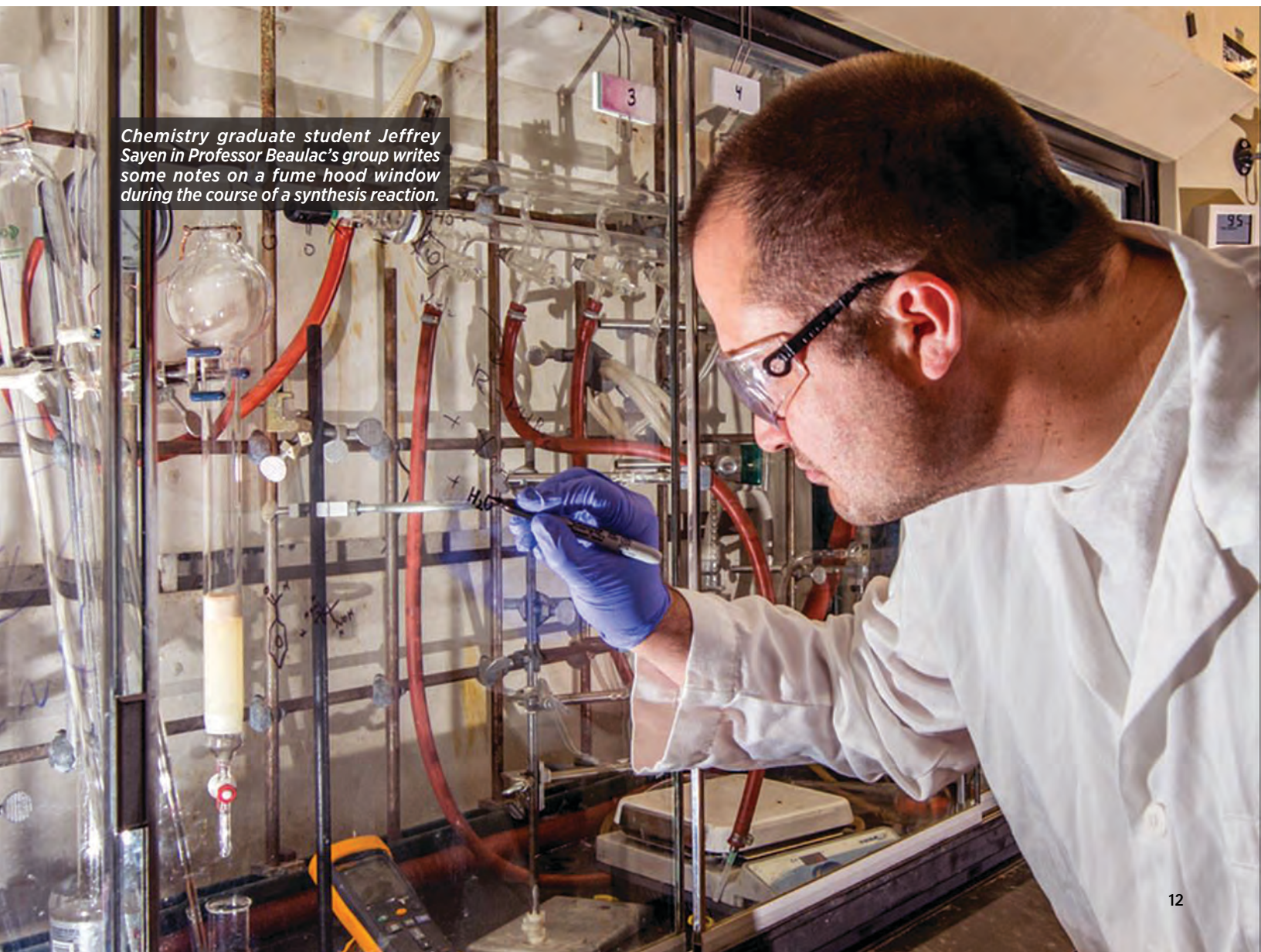
A new student's first interaction with the Department is the Orientation Program, which has been organized and run by the Chemistry Graduate Office and Graduate Students since 1976. Some graduate students in Chemistry elect to participate in Science Theatre, an award-winning campus-wide group of volunteers who, through public demonstrations and presentations, stimulate public interest in science. Science Theatre reaches over 20,000 students, parents, and teachers each year. It has received the 1993 American Association for the Advancement of Science Award for Public Understanding of Science and Technology, and has been featured on CNN's "Headline News" and "Science and Technology Week."

There are also several professional organizations that many in the Department participate in. These include the American Chemical Society, ACS Women in Chemistry, and The National Organization for the Professional Advancement of Black Chemists and Chemical Engineers (NOBCChE). These organizations have all recently won awards for their very active and inventive outreach efforts.

The daily activities within the Department for graduate students are rich and varied. Their typical day may include attending classes, presenting a recitation as a TA, taking in seminars or departmental colloquia, stealing a little time out at one of the University's three fitness gymnasiums or three pool facilities, and of course, research. Many students ask about the time "required" in the lab, after hearing horror stories of long hours required slaving over test tubes. While it's true

that being in graduate school is not the same as having a 9-to-5 job, the time involved in research should be viewed as a learning opportunity, not a chore. Students naturally become excited and enthusiastic about their research, and about being involved in pursuits that yield never-before-obtained results and information, which is a unique and truly exciting experience. Graduate students come back to lab after dinner and on weekends not because they are required to, but because they are eager to find what they will learn next. Research is an exhilarating experience, and this is what motivates the best students. The work that they perform here as graduate students has an impact on Science and a profound effect on what they achieve later on in their professional careers. 📌

*Chemistry graduate student Jeffrey Sayen in Professor Beaulac's group writes some notes on a fume hood window during the course of a synthesis reaction.*



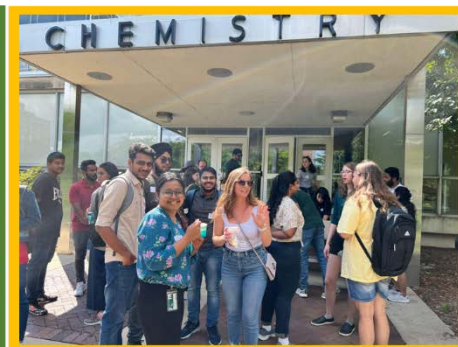
# STUDENT ORGANIZATIONS

are a thriving part of Department life, offering additional support, community, and exciting opportunities.

## Chemistry Graduate Student Organization (CGSO)

The Michigan State University CGSO is a representative organization with the sole aim of fostering professional development and enriching the experience of graduate students within and beyond the chemistry community. Since its inception in 2022, MSU CGSO has organized workshops and panel discussions designed to illuminate alternative career paths in the industry, empowering graduate students with valuable insights and knowledge while nurturing networking opportunities between current graduate students and alumni. Through various events, including but not limited to monthly coffee hours, research days, and social gatherings, we strive to nurture meaningful relationships between graduate students and faculties within the chemistry department.

CGSO is teamed up with the Michigan State University Local Chapter of The American Chemical Society (ACS) to reach a broader community and participate in conferences and workshops. Our association with ACS allows us to actively be involved in local and national ACS-GSO programs, further enhancing the collective impact of our efforts. Additionally, this partnership provides us with access to grants that can support our graduate students' attendance at workshops and conferences, enriching their academic and professional journeys. Membership in MSU CGSO is inclusive, as all graduate students enrolled in the chemistry program at Michigan State University are considered members. We embrace diversity and encourage active involvement from every member of our esteemed institution. In pursuit of effective governance, any eligible member who satisfies the criteria outlined in the CGSO Elections Bylaws is qualified to be an officer of the organization and may serve on any CGSO committee. We believe in transparent and accountable leadership, ensuring that the voices of our members are heard, valued, and respected. Should you have any questions or concerns, we welcome you to reach out to us at [cem.cgso@msu.edu](mailto:cem.cgso@msu.edu), or visit our website at: <https://www2.chemistry.msu.edu/cgso/>. Our dedicated team is eager to address any inquiries and support the success and well-being of our vibrant graduate student community.



## American Chemical Society Women in Chemistry (ACS WiC)

The American Chemical Society Women in Chemistry (ACS WiC) organization is a student-led group with the aim to foster a supportive and welcoming community for all chemists to grow both professionally and personally. While our name is Women in Chemistry, our organization is open for anyone to join! We promote diversity, and as such WiC is composed of an assorted group of individuals ranging from first-year students to students getting ready to graduate. There are no limitations on joining WiC, therefore we encourage all to join our steering committee

WiC is divided into four different subcommittees: social, workshops/professional development, peer mentoring, and outreach. Each of these subcommittees focuses on different goals. Over the years, our social committee has organized different events including but not limited to football tailgates, holiday parties, and county fairs. Our workshops/professional development team focuses on organizing various workshops and panels targeted towards professional development, such as first year panels, graduating student panels, meetings with visiting speakers, and presentation practices. The peer mentoring committee is geared toward first-year students with the goal to make the transition into graduate school as smooth as possible, with the additional perk of making new friends along the way. Through this program first-year students are paired with older graduate students based on a common interest survey. Throughout the year we plan events for students participating in the program, allowing students to come together and further raise a sense of community. With our recent expansion to



include outreach into our array of committees we have been able to work closely with schools in the East Lansing/Lansing area. We currently have a large endeavor in which we are donating chemistry equipment and glassware to local schools. Furthermore, we have done various demonstrations at local schools as well.

Through our various events, the main objective of WiC is to promote a lasting sense of community not only within the department, but also the local area, as well as allow students to develop both professionally and personally in a way that works best for them. We are a part of the local section of the American Chemical Society allowing our team to reach an even broader group of individuals. Please feel free to contact Women in Chemistry if you have any questions or are interested in joining at CEM.ACSWIC@msu.edu, or visit <https://www2.chemistry.msu.edu/acswic/>.



### **Chemistry Research Safety Team (RST)**

The Chemistry Research Safety Team (RST) was established to bridge the communication gap between graduate student safety officers and established safety organizations such as MSU's Environmental Health and Safety (EHS) department and the Safety Committee. The team's mission is to increase safety awareness and promote a safety culture as a core institutional value in all academic and research endeavors within the Department of Chemistry.

With the formation of RST and close collaboration with EHS, safety officers now have an official forum to discuss concerns with their peers, without the pressure or apprehension associated with asking departmental or university-level safety resources independently. If necessary, this organization can act as an intermediary to connect researchers to the appropriate resources within the university. This sense of community within the chemistry department is aimed to increase the overall safety and wellbeing of all students and researchers.

RST hosts monthly meetings and regularly creates posters dubbed "Safety Minutes" that feature safety reminders, as well as "Safety Seconds" that demonstrate individuals displaying proper safety procedures. Monthly fliers can also be found around the department dubbed "Safety Femtoseconds" that aim to equip students with the knowledge and tools necessary to maintain a safe and healthy working environment. The RST also holds safety-related events throughout the year to actively promote a safety culture at MSU. New this year, RST created a forum to report "near misses" in the lab and department to address potential hazards that are encountered and may not be immediately evident. Students and researchers at all levels are encouraged to participate in RST's meetings and events. Please contact the Chemistry Research Safety Team's executive board at CEM.RST@msu.edu.



# AFTER GRADUATION

upon the successful completion of our Ph.D. program, our students have amply demonstrated their ability to conduct vital, independent research. The Chemistry Department and the University are committed to assisting our students in the pursuit of their career goals. Information about academic, governmental and industrial positions and postdoctoral fellowships is updated daily and made available to all graduate students. Assistance in résumé writing is available, and résumés are collected from students and made available to employers upon request. Each year a number of industrial recruiters, frequently MSU Chemistry alumni themselves, visit the Chemistry Department and the University for on-campus interviews of prospective employees.

The University operates an outstanding service for graduating students at all levels through the MSU Career Services Network, which can be reached at (517) 355-9510, or on the web at <http://careernetwork.msu.edu/>. This facility is the focal point for on-campus interviewing, and offers an extensive assortment of resources designed to assist students in the selection and pursuit of career options. Individual advising is available, as well as workshops on job-seeking strategies, résumé writing and interviewing. They stock a wealth of career assessment material, employer literature and information on recent hiring trends, salary levels, and employment opportunities.

Obviously, a comprehensive list of the thousands of MSU Chemistry Department alumni and their current positions cannot be listed here. However, the following list of employers is representative:

## **Selected Corporations with MSU Chemistry Ph.D. Alumni**

3M Company  
Abbott Laboratories  
BP Corporation  
BASF Corporation  
Chevron Corporation  
Novartis Corporation  
DuPont de Nemours Inc.  
Dow Inc.  
Eastman Kodak Company  
Eli Lilly and Company  
ExxonMobil R&D  
Ford Motor Company  
Hewlett Packard  
IBM Research Center  
Merck & Co.  
Monsanto Company  
Procter & Gamble  
Shell Oil Company  
GlaxoSmithKline  
Texas Instruments  
Pfizer  
McCormick & Company

## **Selected Universities with MSU Chemistry Ph.D. Alumni**

George Washington University  
Indiana University  
Miami University (Ohio)  
Morehead State University  
National Taiwan University  
Northwestern University  
Oberlin College  
The Ohio State University  
Oregon State University  
Wayne State University  
Stanford University  
University of Akron  
University of Athens  
University of Crete  
University of Delaware  
University of Florida  
University of Illinois  
University of Kentucky  
University of Michigan  
University of New Mexico  
University of Puerto Rico  
Florida A&M  
Southern Illinois University  
Saginaw Valley State University  
Grand Valley State University  
University of Wisconsin  
College of the Holy Cross

## **National Research Laboratories with Chemistry Ph.D. Alumni (permanent staff and post-doctoral positions)**

Argonne National Laboratory  
Brookhaven National Laboratory  
NASA Jet Propulsion Laboratory  
Lawrence Livermore National Laboratory  
Los Alamos National Laboratory  
Naval Research Laboratory  
Oak Ridge National Laboratory  
Lawrence Berkeley Laboratory  
National Institutes of Health  
National Superconducting Cyclotron Laboratory  
NASA  
National Institute of Standards and Technology  
United States Food and Drug Administration  
Federal Bureau of Investigation

# THE DIVERSE RESEARCH INTERESTS

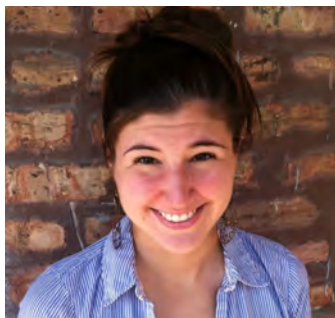
of the Chemistry Faculty do not permit their easy classification into the traditional areas of Chemistry: Analytical, Physical, Organic and Inorganic. However, they are listed here

Faculty Member	Analytical	Inorganic	Organic	Physical	Nuclear	Chemical Physics	Theoretical	Organo-metallic	Biolog
Andorfer, Mary		•	★						•
Beck, Warren F.		•		★		•			•
Blanchard, Gary J.	★								•
Borhan, Babak			★						•
Brown, Kyle W.					★				
Chiu, Melanie			★					•	
Cooper, Melanie M.									
Dantus, Marcos	•			★		•			•
Demir, Selvan		★		•	•			•	
Domnanich, Katharina	•	•			★				•
Draths, Karen			★						•
Fan, Jinda			★			•			•
Gair, Joseph		•	★					•	•
Gaiser, Alyssa				★					•
Geiger, James H.				★					•
Hamann, Thomas		★		•					
Harel, Elad				★					
Hong, Heedeok				•					★
Hu, Jian		•		•					★
Huang, Xuefei	•		★						•
Jackson, James E. (Ned)		•	★				•		
Jin, Xiangshu	•			•					★
Kim, Seokhyoung		★		•					
Lee, Kin Sing Stephen			★						•
Liddick, Sean N.				•	★	•			
Maleczka, Robert E.			★					•	
McCusker, James K.		★		•					
Odom, Aaron L.		★	•					•	
O'Halloran, Thomas V.	•	★							•
Piecuch, Piotr				★	•	•	•		
Posey, Lynmarie A.				•					•
Qiu, Tian (Autumn)	★								•
Severin, Gregory W.		•			★				•
Smith, Milton (Mitch) R. III		★						•	•
Smith, Ruth Waddell	•								
Sun, Liangliang	★								•
Swain, Greg M.	★								•
Tepe, Jetze J.			★						•
Walker, Kevin D.			★						•
Wang, Tuo	•			★					•
Warren, Timothy H.		★	•					•	•
Weliky, David P.	•	•		★		•			•
Wilson, Angela K.		•		★	•	•	•		•
Xie, Weiwei		★							



in a matrix of different aspects of chemistry research and with a broad, descriptive title for their research interests, with their principal interest indicated by a red star (★). More information about the research activities of the Faculty, including their interdisciplinary interests, is provided in the individual descriptions of their research on the pages which follow. 🌟

Disciplinary	Materials	Chemical Education	Forensic	Research Interests
				Enzyme Engineering, Organic Chemistry, Structural Biology
	•			Ultrafast Spectroscopy: Light Harvesting in Photosynthesis and Nanomaterials
	•			Synthesis and Spectroscopy of Interfaces
				Synthetic and Bioorganic Chemistry and Organic Spectroscopy
				Nuclear Chemistry
	•			Physical Organic Approaches to Polymer Synthesis
		★		Evidence-based Approaches to Improving Chemistry Education
				Ultrafast Science
	•			Single-Molecule Magnetism and Synthetic Chemistry with <i>f</i> -Element Compounds
				Nuclear Chemistry
				Sustainable Synthesis, Organic Chemistry, Synthetic Biology
	•			Radiochemistry and Radiotracer Development for PET Imaging
				Selective Catalysis, Organic, Organometallic
				Radiochemistry
				Structural Biology Using X-Ray Crystallography
	•			Inorganic Materials / Electrochemistry
				Deep Spectroscopy for Breakthrough Molecular Discovery
				Biophysical Chemistry of Membrane Protein Folding and Degradation
				Membrane Protein Structure-Function Characterization
	•			Organic Chemistry, Synthetic Chemistry, Nanoscience and Immunology
	•			Mechanism and Design in Green and Organic Materials Chemistry
				Biological and Physical Chemistry, Structural Biology
	•			Nanomaterials Synthesis, Photonics and Solar Energy
				Molecular Mechanism of Dietary Lipids and Environmental Toxicants on Human Health
				Nuclear Chemistry
				Synthetic Organic Chemistry
	•			Synthesis and Spectroscopy of Transition Metal Complexes
				Organometallic/Inorganic Synthesis and Transition Metal Catalysis in Organic Synthesis
				Transition Metal Chemistry of Living Systems and Medicine
				Quantum Chemistry and Physics
		★		Mathematics in Chemistry Education
	•			Analytical Chemistry, Environmental Toxicology, Microbiome-Gut-Brain Axis
				Radiochemistry
	•			Inorganic and Organic Chemistry for Sustainability in the 21 <sup>st</sup> Century
			★	Forensic Chemistry
	•			High-resolution, Ultrasensitive, and Native Proteomics
	•			Electrochemistry, Carbon Material Science, Corrosion and Neuroanalytical Chemistry
				Synthetic and Medicinal Chemistry
				Functional Analysis of Enzymes on Biosynthetic Pathways of Plant-derived Bioactive Compounds
	•			Structural Analysis of Biomolecules and Biomaterials by Solid-State NMR
				Synthetic Inorganic Chemistry for Catalysis and Biology
	•			Biophysical Chemistry and Nuclear Magnetic Resonance
	•			Physical, Theoretical, and Computational Chemistry
				Experimental and Theoretical Quantum Materials



**Mary C. Andorfer**

## Enzyme Engineering, Organic Chemistry, Structural Biology

### ASSISTANT PROFESSOR

B.S.,  
Butler Univ.;  
Ph.D.,  
Univ. of Chicago;  
Postdoctoral Fellow,  
Massachusetts Inst. of Technology.

517-355-9715



#### SELECTED PUBLICATIONS

*Rescuing Activity of Oxygen-Damaged Pyruvate Formate-Lyase by a Spare Part Protein*, Andorfer, M.C.; Backman, L.R.F.; Li, P.L.; Ulrich, E.C.; Drennan, C.L., *J. Biol. Chem.* **2021**, 297, 101423.

*Fixing Nature's Carbon Inefficiencies*, Andorfer, M.C.; Drennan, C.L., *Joule* **2021**, 5, 765.

*Molecular Basis for Catabolism of the Abundant Metabolite trans-4-hydroxy-L-proline by a Microbial Glycyl Radical Enzyme*, Backman, L.R.F.; Huang, Y.Y.; Andorfer, M.C.; Gold, B.; Raines, R.T.; Balskus, E.P.; Drennan, C.L., *eLife* **2020**, 9, e51420.

*Solution Structure and Biochemical Characterization of a Spare Part Protein that Restores Activity to an Oxygen-Damaged Glycyl Radical Enzyme*, Bowman, S.E.J.; Backman, L.R.F.; Bjork, R.E.; Andorfer, M.C.; Yori, S.; Caruso, A.; Stultz, C.M.; Drennan, C.L., *J. Biol. Inorg. Chem.* **2019**, 24, 817.

*Understanding and Improving the Activity of Flavin Dependent Halogenases via Random and Targeted Mutagenesis*, Andorfer, M.C.; Lewis, J.C., *Annu. Rev. Biochem.* **2018**, 87, 159.

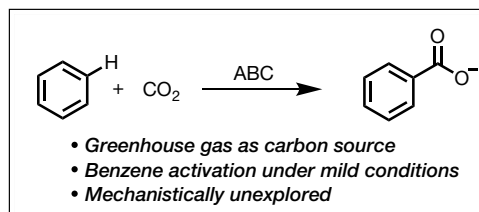
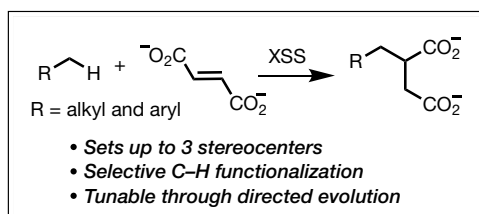
*Understanding Flavin-Dependent Halogenase Reactivity via Substrate Activity Profiling*, Andorfer, M.C.; Grob, J.E.; Hajdin, C.E.; Chael, J.; Siuti, P.; Lilly, J.; Tan, K.L.; Lewis, J.C., *ACS Catal.* **2017**, 7, 1897.

*Directed Evolution of RebH for Catalyst-Controlled Halogenation of Indole C-H Bonds*, Andorfer, M.C.; Park, H.J.; Vergara-Coll, J.; Lewis, J.C., *Chem. Sci.* **2016**, 7, 3720.

*Improving the Stability and Catalyst Lifetime of the Halogenase RebH By Directed Evolution*, Poor, C.B.; Andorfer, M.C.; Lewis, J.C., *ChemBioChem* **2014**, 15, 1286.

*Regioselective Arene Halogenation using the FAD-Dependent Halogenase RebH*, Payne, J.T.; Andorfer, M.C.; Lewis, J.C. *Angew. Chem. Int. Ed.* **2013**, 52, 5271.

The Andorfer lab seeks to develop sustainable biocatalysts for producing value-added chemicals from inexpensive and abundant feedstocks, namely CO<sub>2</sub> and hydrocarbons. We will target enzymes that allow anaerobic microbes to activate components of crude oil (e.g. toluene, *n*-alkanes, and benzene) and subsequently use them as carbon sources for metabolism. Because anaerobic, crude-oil-polluted environments are recalcitrant to typical remediation methods, these enzymes could be useful for bioremediation efforts in anaerobic environments as well. The challenging task of anaerobic hydrocarbon activation is enabled by a range of enzyme cofactors, including both inorganic cofactors (e.g. 4Fe4S clusters) and/or organic radical cofactors (e.g. amino acid radicals). We aim to not only engineer these enzymes for selective catalysis, but also to elucidate molecular-level mechanistic understanding.



We will take two major approaches to study these crude oil degrading enzymes:

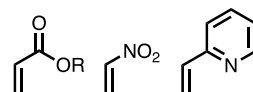
- Directed evolution of selective C-H functionalization biocatalysts for synthetically-useful transformations
- Structural and mechanistic characterization of putative hydrocarbon-degrading enzymes to understand basic principles of how they work

In addition to more traditional organic and molecular biology techniques, members of the group will use single particle cryo-electron microscopy (cryo-EM), EPR spectroscopy, as well as anaerobic enzyme purifications and biochemical assays.

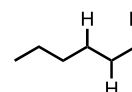
### Directed Evolution of Anaerobic Enzymes -

Directed evolution methodology has been used for decades to repurpose enzymes for synthetically useful organic transformations; however, it has not been used for anaerobic

hydrocarbon activating enzymes due to the complexity of these systems. We will create tools to engineer these enzymes to alter functionality and develop them as synthetically useful catalysts. Some of the reactions we will be exploring will include olefin hydroalkylation and benzene carboxylation.



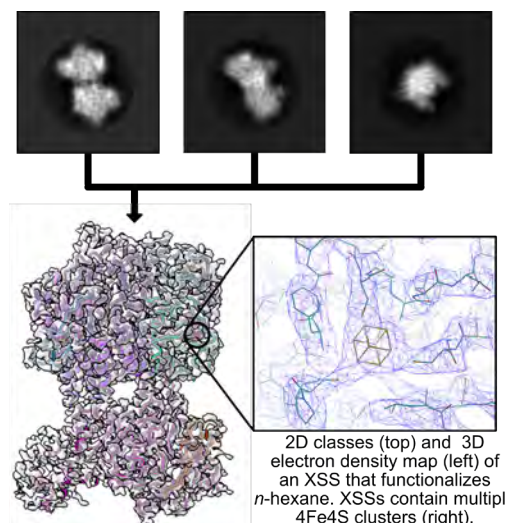
How far can we expand scope of the olefin?



Is C-H functionalization tunable?

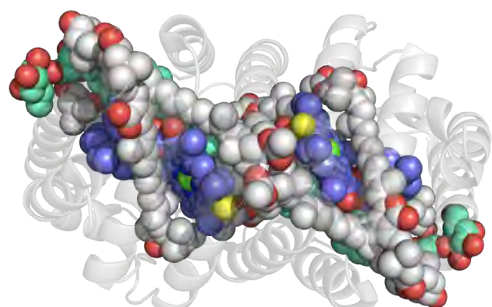


**Single Particle Cryo-EM** - We will use MSU's Talos Arctica electron microscope to collect images to visualize single protein molecules. Single particles can be sorted into 2D classes and used to build 3D electron density maps for the protein of interest. Using these maps, we can build in molecular models to ultimately solve new protein structures. We will leverage the molecular-level mechanistic understanding gained through structure determination to inform protein engineering efforts. 🌟



At Michigan State University, the Beck group has continued its studies of the structures and physical mechanisms that photosynthetic organisms employ to capture the energy of solar photons. Over the last several years, we have reestablished in East Lansing a state-of-the-art experimental program in femtosecond laser spectroscopy to carry out studies of light-harvesting proteins and related systems, with broadband multidimensional electronic spectroscopy as the principal technique used in the most recent work. An important theme has been to determine the structural origin and functional significance of the ultrafast nonradiative relaxation pathways that are enabled by the presence of *molecular excitons*, collective optical excitations of paired or clustered electronic chromophores in a light-harvesting pigment-protein complex.

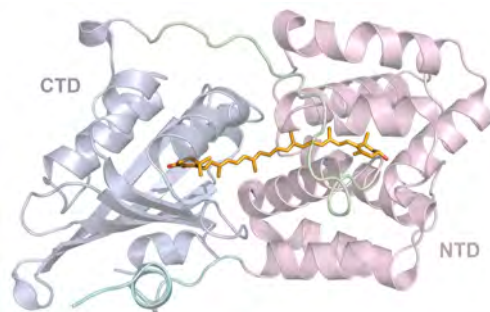
A distinctive aspect of our publications during this period is an additional focus on the molecular mechanisms that induce intramolecular charge transfer (ICT) character in electronic chromophores, initially in carotenoids but now also in bilin (linear tetrapyrrole) chromophores. By combining femtosecond nonlinear spectroscopies with ultrasensitive fluorescence measurements, we have established a new mechanism for the structural dynamics that accompany radiationless decay in carotenoids after optical preparation of the second excited singlet state,  $S_2$ , by absorption of light in the mid-visible range. This work prepared us for a series of publications on the nature of excitation energy transfer pathways and mechanisms in the peridinin-chlorophyll protein (PCP) from marine dinoflagellates. Here we showed that an ultrafast interexciton relaxation mechanism competes with dynamic exciton localization, with both processes intimately involving out-of-plane vibrational motions of the peridinin.



**Structure of the peridinin-chlorophyll protein from marine dinoflagellates.**

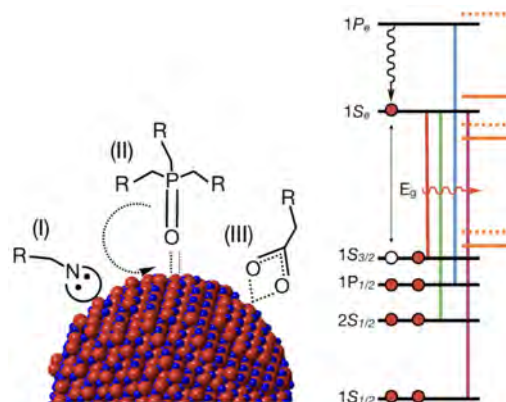
In current work, induction of ICT character and out-of-plane vibrational dynamics are also central to our investigations of the orange carotenoid protein (OCP) and of the intact cyanobacterial phycobilisome. In the OCP, fluorescence anisotropy and 3DES studies of vibrational coherences are being used to determine how excited-state conformational

motions of a ketocarotenoid trigger the conversion of the resting, orange form (OCP<sup>0</sup>) to the active, red form (OCP<sup>R</sup>). 2DES and 3DES studies are also being used in studies of the vibronic excitons in the intact phycobilisome, where we have found that the hydrogen-out-of-plane (HOOP) vibrations of the bilin chromophores contribute to delocalized excitations in ultrafast excitation transfer pathways from the rods to the core segments.



**Structure of the Orange Carotenoid Protein.**

These themes have recently been extended into a new program of studies on the light-harvesting photophysics of CdSe quantum dots (QDs), where the dynamical role of organic surface-capping ligands is being investigated. Our 2DES and 3DES studies of electronic and vibrational coherences in QDs demonstrate for the first time that extensive quantum coherent mixing of the core electronic states with the vibrational states of the ligands imparts a vibronic character to the exciton states. This work establishes a novel *molecular* picture for the exciton states of QDs in which hot-carrier cooling processes involve a coherent nonadiabatic mechanism. 🌟



**Surface-capping organic ligands and exciton energy levels of semiconductor QDs.**



**Warren F. Beck**

## Ultrafast Spectroscopy: Light Harvesting in Photosynthesis and Nanomaterials

**PROFESSOR**

B.S.,  
Davidson College;

Ph.D.,  
Yale Univ.;

Miller Institute Postdoctoral Fellowship,  
Univ. of California, Berkeley.



517-353-1137

### SELECTED PUBLICATIONS

*Vibronic excitons and conical intersections in semiconductor quantum dots*, Tilluck, R.W.; Mohan T.M., N.; Hetherington, C.V.; Leslie, C.H.; Sil, S.; Frazier, J.; Zhang, M.; Leving, B.G.; Van Patten, P.G.; Beck, W.F., *J. Phys. Chem. Lett.* **2021**, *12*, 9677. DOI: 10.1021/acs.jpcclett.1c02630.

*Broadband 2DES detection of vibrational coherence in the  $S_2$  state of canthaxanthin*, Mohan T. M., N.; Leslie, C.H.; Sil, S.; Rose, J.B.; Tilluck, R.W.; Beck, W.F., *J. Chem. Phys.* **2021**, *155*, 035103. DOI: 10.1063/5.0055598.

*Interexciton nonradiative relaxation pathways in the peridinin-chlorophyll protein*, Tilluck, R.W.; Ghosh, S.; Guberman-Pfeffer, M.J.; Roscioli, J.D.; Gurchiek, J.K.; LaFountain, A.M.; Frank, H.A.; Gascón, J.A.; Beck, W.F., *Cell Reports Phys. Sci.* **2021**, *2*, 100380. DOI: 10.1016/j.xcrp.2021.100380.

*Fluorescence anisotropy detection of barrier crossing and ultrafast conformational dynamics in the  $S_2$  state of  $\beta$ -carotene*, Gurchiek, J.K.; Röse, J.B.; Guberman-Pfeffer, M.J.; Tilluck, R.W.; Ghosh, S.; Gascón, J.-A.; Beck, W.F., *J. Phys. Chem. B* **2020**, *124*, 9029. DOI: 10.1021/acs.jpcc.0c06961.

*Structural tuning of quantum decoherence and coherent energy transfer in photosynthetic light harvesting*, Roscioli, J.D.; Ghosh, S.; LaFountain, A. M.; Frank, H.A.; Beck, W.F., *J. Phys. Chem. Lett.* **2018**, *9*, 5071. DOI: 10.1021/acs.jpcclett.8b01919.



## Gary J. Blanchard

### Synthesis and Spectroscopy of Interfaces

#### PROFESSOR

B.S., 1981,  
Bates College;  
Ph.D., 1985,  
Univ. of Wisconsin-Madison;  
Member of Technical Staff, 1985-91,  
Bell Communications Research.

517-353-1105



#### SELECTED PUBLICATIONS

*Quantitating the Binding Energy of Metal Ions to Langmuir-Blodgett Monolayers. The Copper (II)-Octadecylphosphonic Acid System*, Homa Sadeghzadeh and G.J. Blanchard, *J. Phys. Chem. B* **2022**, 126, 3366-3373.

*The Effect of Dilution on Induced Free Charge Density Gradients in Room Temperature Ionic Liquids*, Md. Iqbal Hossain and G.J. Blanchard, *Phys. Chem. Chem. Phys.* **2022**, 24, 3844-3853.

*Intramolecular Relaxation Dynamics Mediated by Solvent-Solute Interactions of Substituted Fluorene Derivatives. Solute Structural-Dependence*, Briana A. Capistran, Stephen H. Yuwono, Mehdi Moemeni, Babak Borhan, James E. Jackson, Piotr Piecuch, Marcos Dantus and G. J. Blanchard, *J. Phys. Chem. B* **2021**, 125, 12486-12499.

*Excited State Dynamics of a Substituted Fluorene Derivative. The Central Role of Hydrogen Bonding Interactions with the Solvent*, Briana A. Capistran, Stephen H. Yuwono, Mehdi Moemeni, Soham Maity, Aria Vahdani, Babak Borhan, James E. Jackson, Piotr Piecuch, Marcos Dantus and G. J. Blanchard, *J. Phys. Chem. B* **2021**, 125, 12242-12253.

*Spectral phase control of the quantum interference between two-photon optical excitation pathways*, J. Lahiri, S. H. Yuwono, I. Magoulas, M. Moemeni, B. Borhan, G. J. Blanchard, P. Piecuch and M. Dantus, *J. Phys. Chem. A* **2021**, 125, 7534-7544.

*Translational Diffusion Dynamics in Divalent Metal Phosphonate Monolayers*, Corbin Livingston and G. J. Blanchard, *Langmuir* **2021**, 37, 7573-7581.

*Effects of Ethanol and n-Butanol on the Fluidity of Supported Lipid Bilayers*, Masroor Hossain and G. J. Blanchard, *Chem. Phys. Lipids* **2021**, 238, 105091, 1-7.

*Ceramide-Mediation of Diffusion in Supported Lipid Bilayers*, Masroor Hossain and G. J. Blanchard, *Chem. Phys. Lipids* **2021**, 238, 105090, 1-7.

The ability to control the physical properties and chemical selectivity of an interface is an issue central to areas of science including cellular function, energy storage, heterogeneous catalysis and chemical sensing. The Blanchard group works on the design, synthesis and characterization of interfaces with an eye toward achieving this control. We are currently focusing our energies on catalytic and ordered systems because of their broad utility.

**Long Range Order in Ionic Liquids** – Ionic liquids are a class of materials that can be described as salts that are liquids at room temperature. These materials are typically viscous fluids and they have found use in areas ranging from organic synthesis to chemical sensing and energy storage. The organization that exists within ionic liquids is not well understood and has until recently been thought to be on the orders of nanometers in length. Our recent work has shown that when ionic liquids are placed in proximity to a charged surface, the charge induces order that persists on the sub-millimeter length-scale – five orders of magnitude greater than expected. These new findings not only provide insight into the structure of these systems, but also open the door to novel applications in energy storage and electronically-controlled optics.

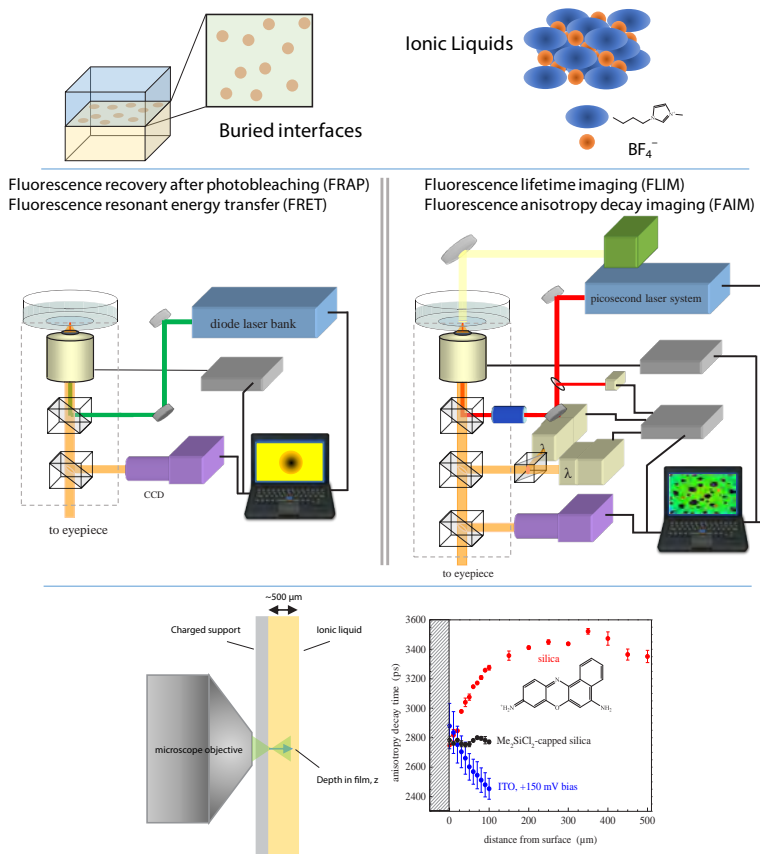
**Characterizing interfacial heterogeneity** – We quantitate molecular motion on molecular length scales and over micron to millimeter length scales, using two complementary microscopy techniques. Using these techniques, we can evaluate the fluidity of a wide range of interfaces and, significantly, we can now characterize transient structural non-uniformities in mono- and bilayer films. This latter capability offers a new way to explore the presence of previously invisible spatial variations in chemical composition, with applications ranging from sensor interface design to in situ plasma membrane characterization.

**Controlling interfacial fluidity** – Covalently bound interfacial adlayers are not

fluid, and fluid adlayers are not physically or chemically robust. These limiting cases have frustrated advances in fields such as molecular-scale lubrication, chemical separations and cellular adhesion. We are developing a novel family of interfaces that can be bound to an interface and at the same time retain the properties of a fluid. Both the thermodynamic driving force for complexation and the kinetics of surface diffusion can be controlled through metal ion complexation, system pH, the surface complexing moieties, and the amphiphile head groups.

### Measuring fluidity in live cell plasma membranes

– Diabetic retinopathy is a disease state that can compromise the vision of diabetic patients. It's origins are thought to be related to chronic exposure to high glucose conditions. Diabetic hyperglycemia leads to changes in the plasma membranes of circulating angiogenic cells which make them less rigid and thus less available to perform their repair functions in vivo. We work with Professor Julia Busik's group (physiology) to evaluate the fluidity of live cell plasma membranes using rotational and translational diffusion measurements of fluorescent molecules introduced to the cells. This work is providing new insight into the molecular-scale consequences of diabetic disease state on cells. 🌱

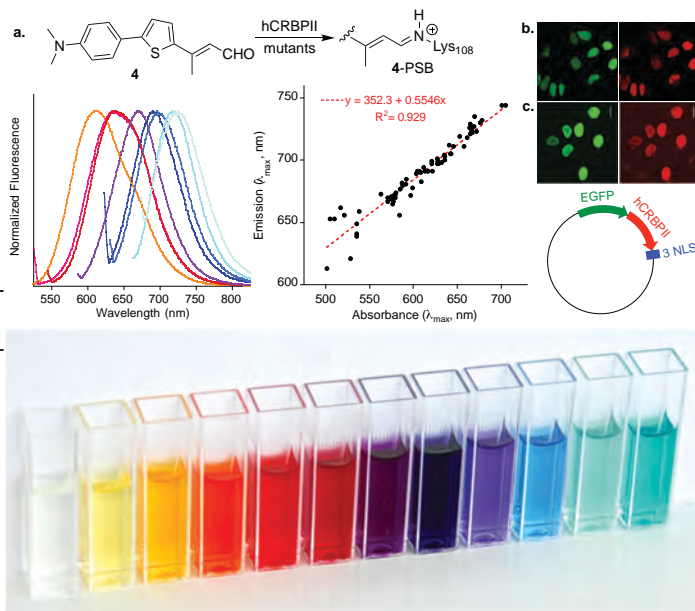


The research interests of our lab can be subdivided into the three main areas of **Bioorganic Chemistry**, **Synthetic Chemistry**, and **Organic Spectroscopy**.

Our **Bioorganic Chemistry** efforts are geared towards elucidation of the interaction of bioactive compounds with receptors and proteins. We rely heavily on de novo protein design and mimicry of natural systems to better understand how certain biological processes occur. As an example, we have initiated research into designing protein mimics of rhodopsin, the protein responsible for vision, which can bind retinal as a protonated Schiff base [PSB] (same binding mode as in rhodopsin). These protein mimics are used to investigate the wavelength regulation mechanism that enables color vision. Currently we are using our engineered proteins as colorimetric and fluorescent proteins for cellular tagging and intracellular pH sensors.

Our **Synthetic Chemistry** program is generally focused on the development of new reactions that utilize simple organic molecules and through designed manipulations lead to more complex systems. In most cases, our method-

In the area of **Organic Spectroscopy**, we are interested in developing host/guest systems that can be used in the absolute stereochemical determination of chiral compounds. We accomplish this through the design and synthesis of chromophoric receptors, which upon binding with the chiral compound function as reporters of chirality. We rely heavily on



## Babak Borhan

### Synthetic and Bioorganic Chemistry and Organic Spectroscopy

PROFESSOR

B.S.,  
Univ. of California, Davis;  
Ph.D.,  
Univ. of California, Davis;  
Postdoctoral Fellow,  
Columbia Univ.



517-353-0501

Circular Dichroism (CD) as the tool for observing the host/guest interactions between the chiral compounds and the receptors. In particular, we will take advantage of the excitonic coupling between independently conjugated chromophores that make up the receptors

#### SELECTED PUBLICATIONS

*Mimicking Microbial Rhodopsin Isomerization in a Single Crystal*, Ghanbarpour, A.; Nairat, M.; Nosrati, M.; Santos, E. M.; Vasileiou, C.; Dantus, M.; Borhan, B.; Geiger, J. H., *J. Am. Chem. Soc.* **2019**, *141*(4), 1735-1741.

*Cu-Catalyzed Oxidation of C2 and C3 Alkyl-Substituted Indole via Acyl Nitroso Reagents*, Zhang, J.; Torabi Kohlbouni, S.; Borhan, B., *Org. Lett.* **2019**, *21*(7), 14-17.

*A Near-Infrared Photoswitchable Protein-Fluorophore Tag for No-Wash Live Cell Imaging*, Sheng, W.; Nick, S. T.; Santos, E. M.; Ding, X.; Zhang, J.; Vasileiou, C.; Geiger, J. H.; Borhan, B., *Angew. Chem. Int. Ed. Engl.* **2018**, *57*, 14742-14746.

*Absolute and relative facial selectivities in organocatalytic asymmetric chloroacylation reactions*, Marzjafari Salehi, N.; Yousefi, R.; Jaganathan, A.; Ashtekar, K. D.; Jackson, J. E.; Borhan, B., *Chem. Sci.* **2018**, *9*, 2898-2908.

*Highly Regio- and Enantioselective Vicinal Dihalogenation of Alkyl Amides*, Soltanzadeh, B.; Jaganathan, A.; Yi, Y.; Yi, H.; Staples, R. J.; Borhan, B., *J. Am. Chem. Soc.* **2017**, *139*(6), 2132-2135.

*Absolute Stereochemical Determination of Asymmetric Sulfoxides via Central to Axial Induction of Chirality*, Gholami, H.; Zhang, J.; Anyika, M.; Borhan, B., *Org. Lett.* **2017**, *19*, 1722-1725.

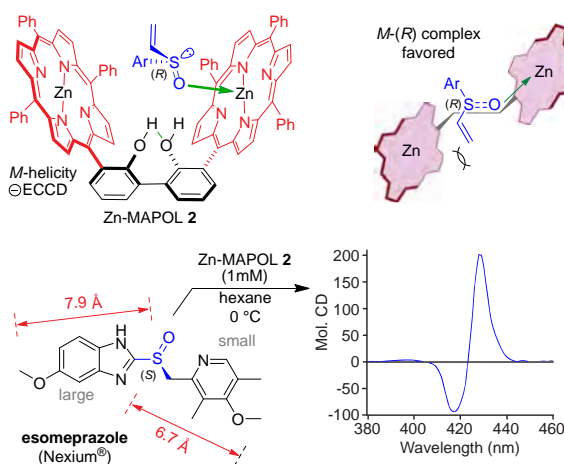
*Nucleophile-Assisted Alkene Activation: Olefins Alone are Often Incompetent, Ashtekar, K.D.; Veticatt, M.; Yousefi, R.; Jackson, J. E.; Borhan, B., Angew. Chem. Soc.* **2016**, *138*(26), 8114-8119.

*Sensing Remote Chirality: Stereochemical Determination of beta-, gamma-, and delta-Chiral Carboxylic Acids*, Tanasova, M.; Anyika, M.; Borhan, B., *Angew. Chem. Int. Ed. Engl.* **2015**, *54*, 4274-4278.

*Tuning the Electronic Absorption of Protein-Embedded All-trans-Retinal*, Wang, W.; Nossioni, Z.; Berbasova, T.; Watson, C. T.; Yapici, I.; Lee, K. S. S.; Vasileiou, C.; Geiger, J. H.; Borhan, B., *Science* **2012**, *338*, 1340-1343.

ologies lead to the production of heterocycles with regio- and stereo-control. These transformations are then highlighted in total syntheses of natural products that exhibit interesting biological activities. Our most recent efforts have focused on developing new catalytic asymmetric olefin halofunctionalization chemistry. These reactions are often catalyzed by (DHQD)<sub>2</sub>PHAL in combination with various N-chlorinated hydantoin as the terminal chlorine sources. Halofunctionalization of different compounds, along with understanding the mechanism of these transformations via NMR, REACT-IR, studies of kinetic isotope effect, and computational analyses are currently under investigation.

to establish non-empirical guidelines for the absolute stereochemical determination of asymmetric centers. ☘





## Kyle W. Brown Nuclear Chemistry

### ASSISTANT PROFESSOR

B.S.,  
Indiana Univ.;  
Ph.D.,  
Washington Univ. St. Louis;  
Faculty,  
Facility for Rare Isotope Beams.

517-908-7267



My research focuses on using nuclear reactions to probe how nuclear matter assembles in systems ranging from nuclei to neutron stars. This work is split between two main concentrations: utilizing reactions to determine the nuclear equation of state and to understand exotic decay modes in nuclei.

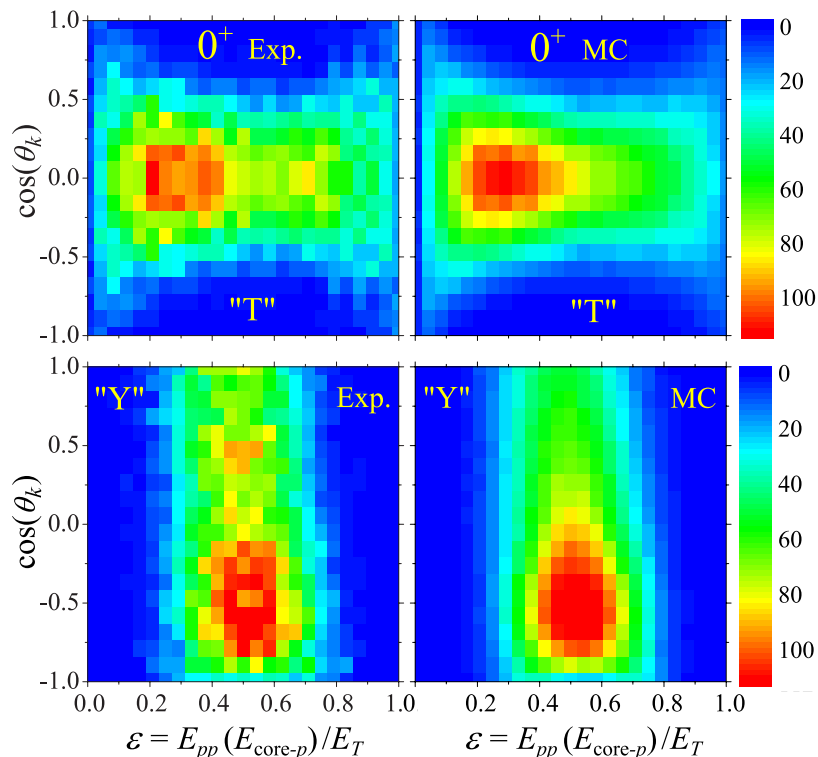
After the groundbreaking measurement of a neutron-star merger two years ago, there has been a renewed interest in pinpointing the nuclear equation of state for matter about twice as dense as found in the middle of heavy nuclei. In particular, we seek to understand the density and momentum dependence of the symmetry energy. This is a repulsive term in the binding energy that arises from an imbalance in the numbers of protons and neutrons. Using heavy-ion collisions, my group can create these very dense environments in the laboratory, and by studying the particles that are ejected from the collision we can help determine the symmetry energy.

My second research focus is using reactions to populate some of the shortest-lived nuclei and studying their decays. The most recently discovered type of nuclear decay is the two-nucleon decay, where the nucleus spontaneously emits two protons or two neutrons in a single decay. These decays occur in nuclei at the extremes of neutron-to-proton ratios. By measuring the energy and angle of the nucleons relative to the remaining

core, one can determine information about the original decaying nucleus, such as the excitation energy and lifetime. By modeling the data, we can also learn about the behavior of the nucleons inside of the nucleus prior to the decay.

These experiments are typically performed using small arrays of silicon and cesium-iodide detectors. Quite often we will use the High-Resolution Array (HiRA), which is a modular array of telescopes made of a combination of one to two silicon detectors followed by four cesium-iodide detectors arranged in quadrants behind them. These telescopes provide excellent energy and angular resolution, and the combination of detectors determines the identity of the charged particle. These detectors are often paired with neutron detectors, gamma detectors, and/or the S800 spectrometer.

Students in my group will take leading roles in the setup, execution, and analysis of these experiments. This can include design and testing of new detector systems, computer simulations of the experiment, or theoretical modeling depending on the interests of the student. Future experiments include using nuclear structure inputs to constrain the neutron skin in heavy nuclei, measuring two-proton decay in the A-30 mass region, and measuring transverse and elliptical flow observables from heavy-ion collisions. 🌟



**Energy-angular correlations for the two-proton decay of the ground state of  $^{16}\text{Ne}$ . The experimentally measured distributions (left) are compared to a three body model prediction adjusted for detector resolution (right).**

### SELECTED PUBLICATIONS

First observation of unbound  $^{10}\text{O}$ , the mirror of the halo nucleus  $^{10}\text{Li}$ , T.B. Webb et al. *PRL* **2019**, 112, 122501.

Large longitudinal spin alignment generated in inelastic nuclear reactions, D.E.M. Hoff et al. *Phys. Rev. C* **2018**, 97, 054605.

Observation of long-range three-body Coulomb effects in the decay of  $^{16}\text{Ne}$ , K.W. Brown et al. *Phys. Rev. Lett.* **2014**, 113, 232501.

What makes a material hard vs. soft; conductive vs. insulating; degradable vs. persistent? How do the molecular features of a polymeric material affect its physical properties and performance? How can we harness the tools of synthetic chemistry and our understanding of chemical reactivity to tailor the properties of polymeric materials? Driven by these overarching questions, **researchers in the Chiu group will gain expertise in molecular synthesis and studying chemical reactivity in a collaborative environment that embraces organic chemistry, polymer chemistry, and materials science and engineering.**

Remarkable innovations over the past few decades in controlled polymerization techniques and post-polymerization functionalization have enabled access to myriad well-defined polymer structures incorporating a broad range of functional groups. Building on these important, ongoing advances, a vigorously growing area of interest in polymer chemistry is the development and study of polymerization systems that can be modulated by external stimuli. Among several intriguing external stimuli, we are particularly interested in the use of **light as a tool in polymer synthesis** because it is orthogonal to many of the functional groups we seek to manipulate chemically and also because so many parameters of illumination can be tuned and automated by modern optics: timing, location, wavelength, and intensity.

Taking advantage of these features, one project features the **design, synthesis, and evaluation of photochromic polymerization agents** that enable us to tune polymer molecular weight distribution using light. We seek to expand this concept to the photomodulation of polymer tacticity and

copolymer sequence. We expect these methods to find application and impacts in advanced manufacturing techniques, like 3D printing, as well as in the quest to develop more sustainable and degradable plastics.

Another focus in the group that utilizes light as a synthetic tool is the development of **photoactivated single-chain polymer nanoparticles (SCNPs)**. SCNPs are polymer chains that undergo intramolecular cross-linking, similar to the folding of a peptide into a protein with tertiary structure. In addition to the biomedical applications of these species (e.g. drug delivery), SCNPs have demonstrated promise as catalysts. A challenge in this area is the incorporation of unsaturated, catalytically active metal species into SCNPs. Our group seeks to overcome this hurdle by developing SCNPs in which metal complexes are activated by light-induced ligand dissociation. We will characterize and evaluate the reactivity of these metal-functionalized SCNPs, and expect that this work will result in the development of more robust and recyclable catalysts that exhibit new or complementary reactivity compared to their small molecule counterparts, as well as the development of polymeric materials with interesting optical and magnetic properties.

In addition to our work on using light as a tool for polymer synthesis, we are also engaged in a variety of collaborative projects. For example, we are collaborating with materials scientists to develop **polymeric electrode binders** to enhance the performance of lithium-sulfide batteries, which are a promising, next-generation technology for electric vehicles. In another project, we are working with computational chemists to **study how copolymer sequence can give rise to emergent properties**, like self-replication. 🌱



## Melanie Chiu

### Physical Organic Approaches to Polymer Synthesis

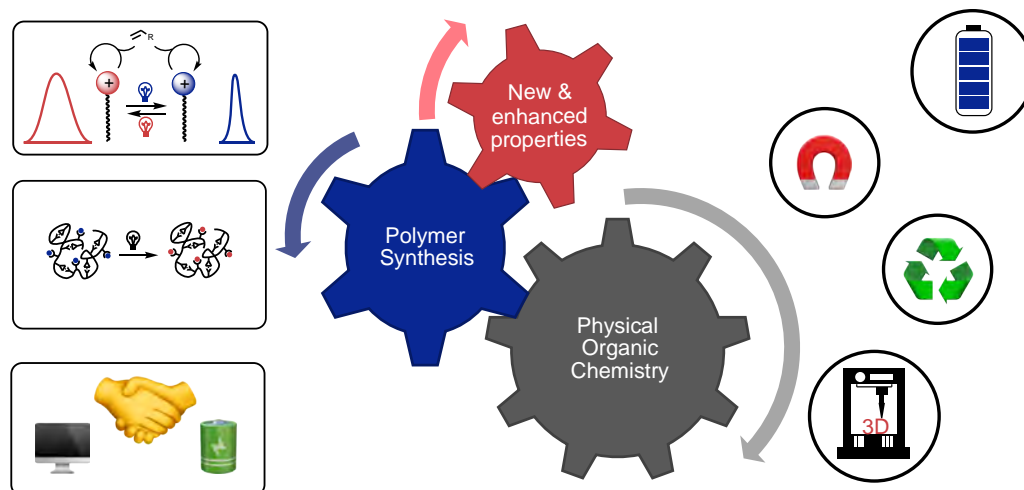
#### ASSISTANT PROFESSOR

A.B.,  
Dartmouth College;  
Ph.D.,  
Univ. of California, Berkeley;  
Postdoctoral Researcher,  
ETH Zürich;  
Postdoctoral Researcher,  
Stanford Univ.  
Assistant Professor,  
Stony Brook Univ.

517-355-9715



### Chiu Crew Research Overview



Physical organic chemistry driving polymer synthesis discoveries for next-generation catalysis, sustainability, and manufacturing

#### SELECTED PUBLICATIONS

*Synthesis strategies for non-symmetric photochromic diarylethenes*, Sponza, A. D.; Liu, D.; Chen, E. P.; Shaw, A.; Diawara, L.; Chiu, M., *Org. Biomol. Chem.* **2020**, *18*, 7238-7252. Featured in the 2020 HOT Paper Collection.

*Modulating polymer dispersity using light: cationic polymerization of vinyl ethers using photochromic initiators*, Liu, D.; Sponza, A. D.; Yang, D.; Chiu, M., *Angew. Chem. Int. Ed.* **2019**, *58*, 16210. Selected as a Hot Paper.

*Disentanglement of excite-state dynamics with implications for FRET measurements: two-dimensional electronic spectroscopy of a BODIPY-functionalized cavitand*, Otto, J.; Wang, L.; Pochorovski, I.; Blau, S. M.; Aspuru-Guzik, A.; Bao, Z.; Engel, G. S.; Chiu M., *Chem. Sci.* **2018**, *9*, 3694.

*Strain-Accelerated Formation of Chiral, Optically Active Buta-1,3-dienes*, Chiu, M.; Tchitchanov, B.; Zimmerli, D.; Sanhueza, I. A.; Schoenebeck, F.; Trapp, N.; Schweizer, W. B.; Diederich, F., *Angew. Chem. Int. Ed.* **2015**, *54*, 349



**Melanie M. Cooper**

## Evidence-based Approaches to Improving Chemistry Education

LAPPAN-PHILLIPS PROFESSOR OF SCIENCE EDUCATION  
AND  
PROFESSOR OF CHEMISTRY

B.S.,  
Univ. of Manchester, England;  
M.S.,  
Univ. of Manchester, England;  
Ph.D.,  
Univ. of Manchester, England;  
Professor,  
Clemson University;  
Honorary Doctor of Science,  
Univ. of South Florida;  
Fellow,  
Royal Society of Chemistry.

517-353-1114



### SELECTED PUBLICATIONS

Developing computational resources to automate analysis of students' London Dispersion force explanations. Noyes, K.N. Cooper, M.M., *J. Chem. Educ.* **2020**, 97, 11, 3923–3936. <https://doi.org/10.1021/acs.jchemed.0c00445>

Arrows on the Page Are Not a Good Gauge: Evidence for the Importance of Causal Mechanistic Explanations about Nucleophilic Substitution in Organic Chemistry. Crandell, O.M.; Lockhart, M.A.; Cooper, M.M., *J. Chem. Educ.* **2020**, 97 (2), 313–327. <https://doi.org/10.1021/acs.jchemed.9b00815>.

Organic Chemistry, Life, the Universe and Everything (OCLUE): A Transformed Organic Chemistry Curriculum. Cooper, M.M.; Stowe, R.L.; Crandell, O.M.; Klymkowsky, M.W., *J. Chem. Educ.* **2019**, 96 (9), 1858–1872. <https://doi.org/10.1021/acs.jchemed.9b00401>. ACS Editors Choice

Investigating Student Understanding of London Dispersion Forces: A Longitudinal Study. Noyes, K.; Cooper, M.M., *J. Chem. Educ.* **2019**, 96 (9), 1821–1832. <https://doi.org/10.1021/acs.jchemed.9b00455>.

Chemistry Education Research—From Personal Empiricism to Evidence, Theory, and Informed Practice. Cooper, M.M.; Stowe, R.L., *Chem. Rev.* **2018**, 118 (12), 6053–6087. <https://doi.org/10.1021/acs.chemrev.8b00020> ACS Editors Choice

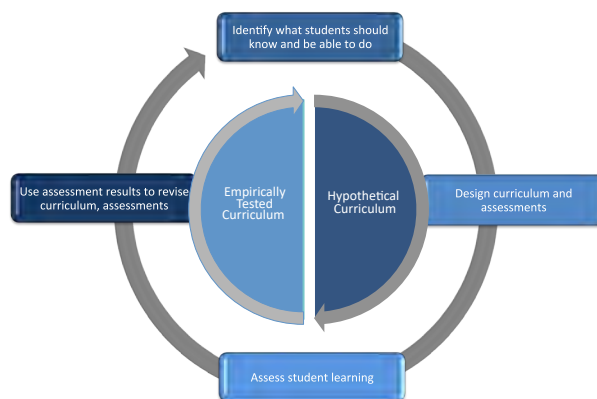
Evaluating the Extent of a Large-Scale Transformation in Gateway Science Courses. Matz, R.L.; Fata-Hartley, C.L.; Posey, L.A.; Laverty, J.T.; Underwood, S.M.; Carmel, J.H.; Herrington, D.G.; Stowe, R.L.; Caballero, M.D.; Ebert-May, D.; Cooper, M.M., *Sci. Advances* **2018**, 4 (10), eaau0554. <https://doi.org/10.1126/sciadv.aau0554>.

The focus of our research is to develop evidence-based approaches to teaching, learning and assessment. Our work involves a wide range of activities and methods including designing ways to assess both what students know and how they use their knowledge, developing curriculum materials, and evaluating the effects of transformation efforts both within and across disciplines.

Our approach to curriculum transformation uses a design-based research cycle in which we identify what students should know and be able to do, design and implement a curriculum that would meet these goals, assess student achievement, and use the results of the assessments to revise the curriculum and accompanying assessment materials. These assessments require students to construct (free form) structures, diagrams, and models, and to develop explanations for phenomena. Our formative assessment system, beSocratic (<http://besocratic.com>), is designed to recognize and respond to student input.

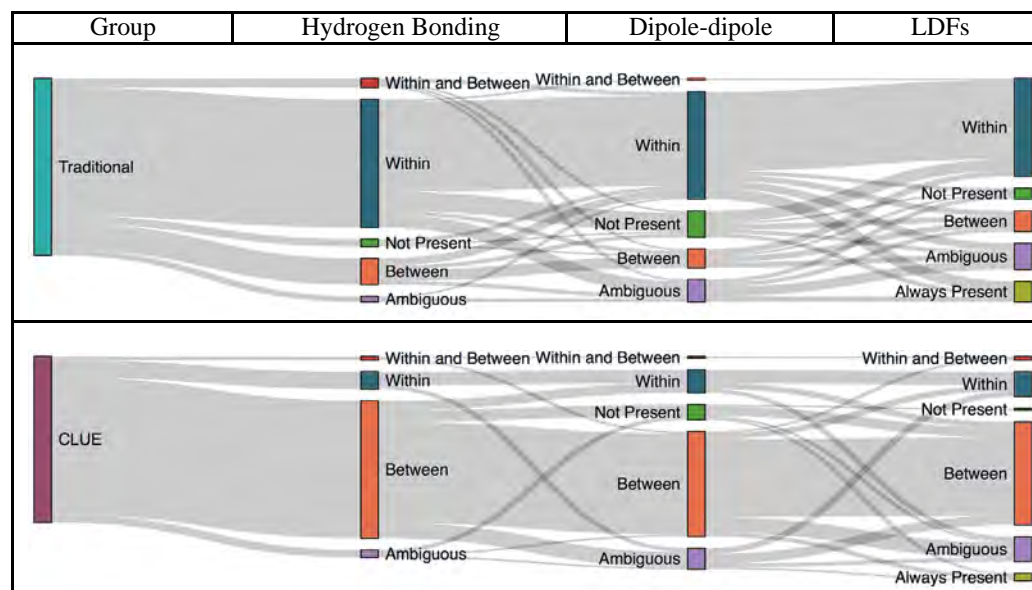
Examples of this process are *Chemistry, Life, the Universe and Everything (CLUE)*, an NSF supported general chemistry curriculum, and *Organic Chemistry, Life, the Universe and Everything (OCLUE)* (both developed in collaboration with Mike Klymkowsky, University of Colorado at Boulder).

Using this system, we have evaluated how students in both traditional and CLUE curricula understand a range of chemical ideas and phenomena. For example, we have shown that both CLUE and OCLUE students are more likely to construct causal mechanistic Design research cycle



explanations for phenomena such as acid-base reactions, nucleophilic substitutions and how London dispersion forces arise.

Current research projects include investigations of the impact of classroom culture on student learning, how students learn to use mechanistic arrows to predict and explain reactions, how energy ideas are used across disciplines, how mechanistic reasoning emerges across disciplines. 🌱



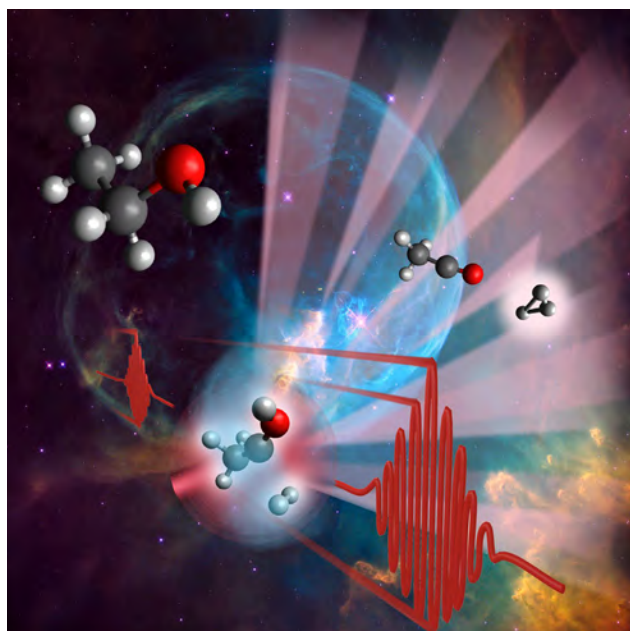
Sankey diagram showing how CLUE and traditional students represent intermolecular forces as within or between molecules.



Ultrafast lasers, with pulse durations shorter than  $10^{-13}$  s, less time than it takes for atoms to move, have already led to three Nobel Prizes in Chemistry and Physics. Our group has two well-funded thrust areas research:

**(a) Understanding and controlling chemistry under intense laser field radiation -**

Within the optical period of an intense laser an electron is pulled out from a molecule, it is accelerated, and then is driven back to the molecule as the laser field reverses its direction. The resulting high-energy electron collision results in exotic types of chemical reaction mechanisms, that have either never been observed or very little is known about their dynamics. These reactions are relevant to astrochemistry, chemical reactions occurring under X-ray radiation, and electron impact mass spectrometry. In our lab, we take advantage of laser sources and pulse shaping methods we have developed to understand and control the dynamics of chemistry induced by strong laser fields. Our recent projects include studies of chemical reactions relevant to interstellar chemistry and the formation of  $H_3^+$ .  $H_3^+$  is the most important ion in the universe because it is responsible for the formation of most organic molecules in the universe and perhaps responsible for life in the universe. Its formation from organic molecules requires dissociation and formation of multiple chemical bonds in about  $10^{-13}$  seconds. Our group is focusing on fundamental processes which proceed through the formation of a neutral  $H_2$  molecule that roams the precursor until it extracts an additional proton. More recently started exploring the dynamics of retro-Diels-Alder reactions in radical cations. We have found that concerted bond breaking is correlated with coherent vibrational motion in the molecular ion.



**(b) Developing tools and compounds for controlling chemistry in space and time -**

The ability to design light pulses that drive a specific chemical reaction enables technological advances in a range of fields from sensing, to energy conversion, to green chemistry. Thus, it is essential that new strategies towards this grand challenge are developed. This project is enhanced by close collaboration between synthesis, theory, and spectroscopy. A specific goal is to understand how to circumvent spontaneous energy flow to achieve chemical reactivity in excited states. For this project we use a wide range of frequency and time-resolved spectroscopies. The capabilities developed here will influence a range of fields that benefit from precise control of quantum objects, e.g. novel strategies for super-resolution microscopy, coherent control of chemical reactions, nanophotolithography, and strategies for creating luminescent centers in transparent materials that can be used for quantum information sciences.



This project implements novel strategies for quantum control of energy flow and reactivity in large organic molecules. Recognizing that different electronic excited states may be highly reactive, shaped laser pulses will be used to (a) populate electronic states with desirable reactivity, and (b) minimize the probability of spontaneous transition out of the desired electronic state. In pursuit of (b), quantum control strategies that range from semi-classical (driving the vibrational wave packet along a particular reaction coordinate) to quantum strategies with no classical analogue will be used. For example, topological effects near intersections between electronic states can be exploited to influence the reaction outcome and strong coupling, where the potential energy surfaces are dressed by the light field, can alter the natural energy flow enhancing coherence with the driving field. ☛



**Marcos Dantus**  
**Ultrafast Science**

**MSU FOUNDATION PROFESSOR**  
AND  
**UNIVERSITY DISTINGUISHED**  
**PROFESSOR OF CHEMISTRY**  
AND  
**ADJUNCT PROFESSOR OF PHYSICS**

B.A. & M.A.,  
Brandeis Univ.;  
Ph.D.,  
California Institute of Technology;  
Postdoctoral Research Fellow,  
California Institute of Technology;  
Member, 2014–,  
National Academy of Inventors.



517-353-1191

**SELECTED PUBLICATIONS**

*Ultrafast disruptive probing: simultaneously keeping track of tens of reaction pathways*, B. Jochim, L. Dejesus, M. Dantus, *Rev. Sci. Instr.* **2022**, 93, 033003.

*Human Serum Albumin Dimerization Enhances the  $S_2$  Emission of Bound Cyanine IR806*, J. Lahiri, S. Sandhu, B. G. Levine, M. Dantus, *J. Phys. Chem. Lett.* **2022**, 13, 1825-1832.

*Intramolecular Relaxation Dynamics Mediated by Solvent-Solute Interactions of Substituted Fluorene Derivatives. Solute Structural-Dependence*, B. Capistran, S. Yuwono, M. Moemeni, S. Maity, A. Vahdani, B. Borhan, J. Jackson, P. Piecuch, M. Dantus, G. Blanchard, *J. Phys. Chem. B* **2021**, 125, 12486-12499.

*Excited State Dynamics of a Substituted Fluorene Derivative. The Central Role of Hydrogen Bonding Interactions with the Solvent*, B. Capistran, S. Yuwono, M. Moemeni, S. Maity, A. Vahdani, B. Borhan, J. Jackson, P. Piecuch, M. Dantus, G. Blanchard, *J. Phys. Chem. B* **2021**, 125, 12242-12253.

*Linear and Nonlinear Optical Processes Controlling  $S_2$  and  $S_1$  Dual Fluorescence in Cyanine Dyes*, M. Laboe, J. Lahiri, N. Mohan T. M., F. Liang, B. Levine, W. Beck, M. Dantus, *J. Phys. Chem. A* **2021**, 125, 9770-9784.

*Controlling Quantum Interference between Virtual and Dipole Two Photon Optical Excitation Pathways Using Phase-Shaped Laser Pulses*, J. Lahiri, S. H. Yuwono, I. Magoulas, M. Moemeni, B. Borhan, G. J. Blanchard, P. Piecuch and M. Dantus, *J. Phys. Chem. A* **2021**, 125, 7534-7544.

*A comparison of strategies for state-selective coherent Raman excitation*, J. Stamm, and M. Dantus, *J. Raman Spectroscopy* **2021 (Special issue)**, 29, 14314-14325.

*Femtosecond dynamics and coherence of ionic retro-Diels-Alder reactions*, S. Li, B. Jochim, J. E. Jackson, and M. Dantus, *J. Chem. Phys.* **2021**, 155, 044303



## Selvan Demir

### Single-Molecule Magnetism and Synthetic Chemistry with f-Element Compounds

#### ASSISTANT PROFESSOR

B.S.,  
Univ. of Cologne, Germany;  
M.S.,  
Univ. of Cologne, Germany;  
Ph.D.,  
Univ. of Cologne, Germany;  
Research during Ph.D.,  
University of California, Irvine;  
FCI Doctoral Scholarship;  
Postdoctoral Fellow,  
Univ. of California, Berkeley;  
Postdoctoral Researcher,  
Lawrence Berkeley National Laboratory;  
DAAD Postdoctoral Fellowship,  
Junior Professor,  
Univ. of Goettingen, Germany;  
Assistant Professor,  
Michigan State University.

517-353-1080



#### SELECTED PUBLICATIONS

*Isolation of the Elusive Bisbenzimidazole Bbm<sup>3-</sup> Radical Anion and its Employment in a Metal Complex*, Benner, F.; Demir, S., *Chem. Sci.* **2022**, *13*, 5818. **Highlighted on the Inside Front Cover.**

*Taming Salophen in Rare Earth Metallocene Chemistry*, Castellanos, E.; Benner, F.; Demir, S., *Inorg. Chem. Front.* **2022**, *9*, 1325-1336. **Selected for Outside Front Cover.**

*Heteroleptic Rare-Earth Tris(metalloenes) Containing a Dibenzyccyclooctatetraene Dianion*, Pugliese, E. R.; Benner, F.; Castellanos, E.; Delano, IV, F.; Demir, S., *Inorg. Chem.* **2022**, *61*, 2444-2454. **Highlighted on the Cover.**

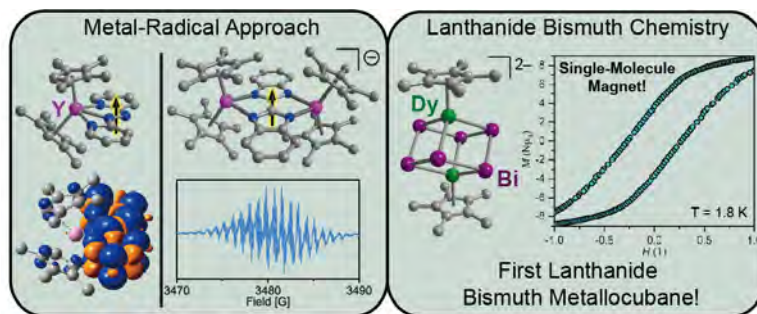
*Organometallic Lanthanide Bismuth Cluster Single-Molecule Magnets*, Zhang, P.; Benner, F.; Chilton, N. F.; Demir, S., *Chem* **2022**, *8*, 717-730. **Highlighted on the Front Cover.**

*A Rare Earth Metallocene Containing a 2,2'-Azopyridyl Radical Anion*, Delano IV, F.; Castellanos, E.; McCracken, J.; Demir, S., *Chem. Sci.* **2021**, *12*, 15219-15228. **Highlighted on the Outside Front Cover.**

*Giant Coercivity and High Magnetic Blocking Temperatures for N<sub>3</sub><sup>3-</sup> Radical-Bridged Dilanthanide Complexes Upon Ligand Dissociation*, Demir, S.; Gonzalez, M. I.; Darago, L. E.; Evans, W. J.; Long, J. R., *Nat. Commun.* **2017**, *8*, 2144.

Single-molecule magnets (SMMs) are molecules that behave like nanoscopic bar magnets. They are interesting due to various potential applications in high-density information storage, molecular spintronics, and magnetic refrigeration. The challenge in realizing these applications lies in designing molecular magnets that have high operating temperatures.

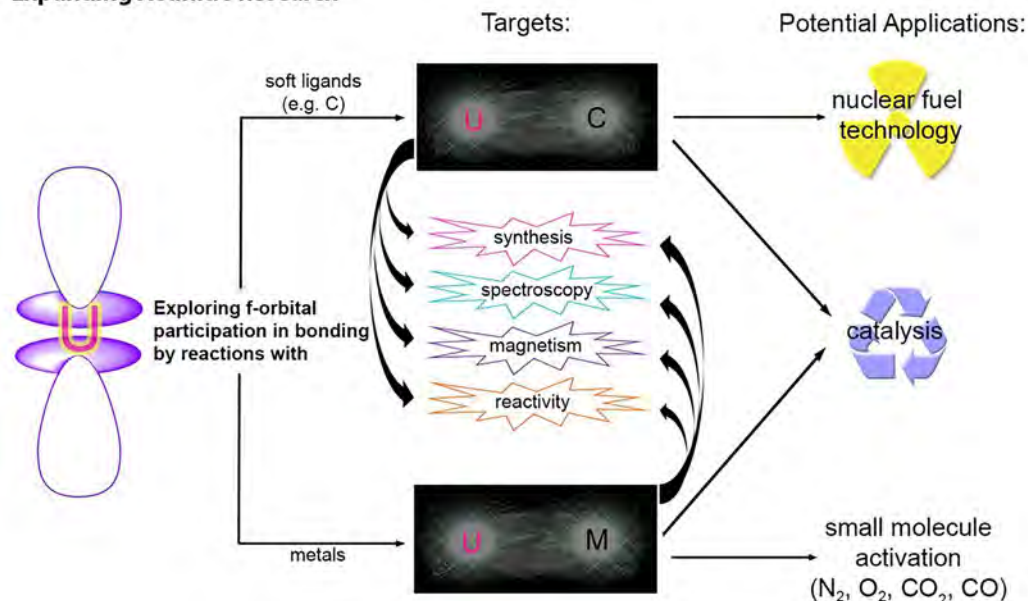
The high magnetic anisotropic nature of lanthanide ions renders them particularly well-suited for the design of SMMs. This property arises from unquenched orbital angular momentum and strong spin-orbit coupling. To suppress quantum tunneling relaxation processes that lead to a shortcut of the maximum spin-relaxation barrier and thus, a weaker magnet, strong exchange coupling between the spins is required. This can be accomplished by using radical ligands with diffuse spin orbitals to penetrate the core electron density of the deeply buried 4f orbitals. We synthesize new radical ligands and investigate the spin density distributions via EPR and computational methods. Subsequently, we explore their utility for the design of radical-containing lanthanide SMMs. Another successful approach to strong coupling targets the use of heavy p-block elements since their diffuse valence orbitals facilitate better penetration of the core electron density of the lanthanide ions relative to their lighter diamagnetic analogs. In this regard, our current focus is particularly on the chemistry of bismuth, which is synthetically challenging, yet intriguing as bismuth combines with other elements in surprisingly rich ways.



Quantum computers contain 'qubits' (short for quantum bits) as their functional units and are the next generation computers. They rely on principles of quantum information science and can execute complex algorithms which cannot be run on classical computers. A molecular approach to qubits is rare and we develop new molecular spin qubits by implementing the lanthanide ions.

Uranium's rich chemistry lies in certain properties that results in chemical bonding and reactivity that are not seen with other elements. Uranium-ligand multiple bond compounds have been recognized as promising subjects of study for advancing uranium catalysis and actinide/lanthanide separation by shedding light on the extent of covalency in bonding of 5f orbitals. Covalency is expected to be more prominent when softer ligands are used such as C ligands rather than N or O ligands. Hence, investigating the electronic and reactivity properties of molecular uranium carbenes will improve fundamental knowledge that is crucial to the development of catalysts and new generation nuclear fuels. Besides uranium carbenes, we pursue uranium-metal bonds that are extremely rare. Such bonding moieties will uncover which 5f orbitals are involved.

#### Expanding Actinide Research



At the Facility for Rare Isotope Beams (FRIB) a plethora of by-product radionuclides will be created that are of immense societal value for a number of disciplines, viz. nuclear medicine, plant biology, material science, astrophysics and stockpile stewardship science. It is an ambitious endeavor to collect these rare radionuclides at sub-nanomolar levels from the vast amount of cooling water, radiochemically purify them, and finally transfer them into a chemical form that is required for the specific applications. So far, the feasibility of 'isotope harvesting' was already probed at the National Superconducting Cyclotron Laboratory (NSCL). The next step will involve a translation towards the conditions at FRIB, where challenges like considerably increased levels of radioactivity, diluted in a greatly larger water volume will be met.

Additionally, in the normal operation mode of FRIB a broad variety of multiple isotopes of each element will be created, and often direct harvesting efforts will not yield radioisotopically pure samples. Currently this limitation is addressed by focusing on the collection of so-called 'radionuclide generator pairs', where the decaying parent radionuclide generates the desired daughter radionuclide. An option to further increase the spectrum of available pure radioisotopes would be through the implementation of mass separation. For this task, we envision to utilize the on-site available Re-Accelerator (ReA) facility.

in the last decades. We will introduce the necessary modifications at ReA and develop mass separation capabilities for the harvested radionuclides.

**Radioactive Targetry for Neutron Studies and Ion Sources** – Particular focus will be directed towards collecting and separating radionuclides which are of interest for scientific studies, such as neutron reaction studies. Precise measurement of neutron capture cross sections is imperative to elucidate the processes in cosmic environments as well as to address national security questions within the framework of the Stockpile Stewardship Program. Theoretical calculations of these cross sections are often afflicted with large uncertainties, as such only experimental efforts can address these data needs. However, a great challenge in the performance of neutron cross section studies with radioactive samples is to obtain the necessary amount of material (up to microgram quantities) at high radioisotopic purity. For the Stockpile Stewardship Program the isotopes of Eu, Lu and Tm are of priority, while the s-process branch-point isotopes viz.  $^{63}\text{Ni}$ ,  $^{79}\text{Se}$ ,  $^{147}\text{Nd}$ ,  $^{147,148}\text{Pm}$ ,  $^{153}\text{Gd}$ ,  $^{160}\text{Tb}$ , etc. are of interest for astrophysics research. To address these nuclear data needs, we will use the obtained mass-separated samples to manufacture radioisotopically pure targets. These targets will be utilized in neutron reaction studies, where we would like to collaborate with neutron source facilities and research reactors.



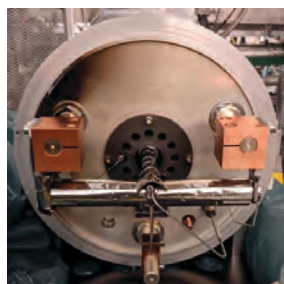
## Katharina A. Domnanich Nuclear Chemistry

### ASSISTANT PROFESSOR

B.Sc.,  
Dublin Inst. of Technology, Ireland;  
M.Sc.,  
Univ. of Vienna, Austria;  
Ph.D.,  
Univ. of Bern, Switzerland;  
Research Associate,  
National Superconducting Cyclotron  
Laboratory, Dept. of Chemistry,  
Michigan State Univ.



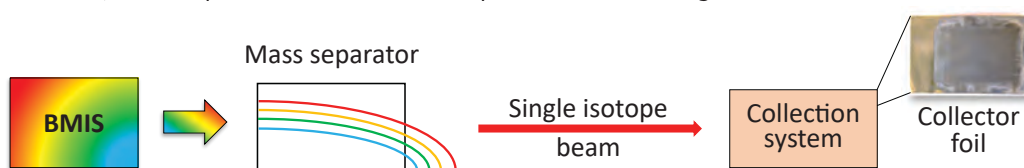
517-353-1137



**$^{32}\text{Si}$  ion source (left) to facilitate the stand-alone operation of the ReA-facility. The ion sources are introduced into the Batch Mode Ion Source module (right).**

Within this approach, the introduced isotopic mixtures will be separated according to the different mass-to-charge ratio, followed by the collection of the purified isotopes. This concept is inspired by the isotope separator facilities CERN-MEDICIS, Switzerland and TRIUMF, Canada, which pioneered this technique

Additionally, to compensate for the utilization of ReA's mass separator, we will support the stand-alone operation of this facility by the preparation of radioactive ion sources with the harvested radionuclides. The establishment of such a synergistic approach will facilitate the development of multi-user capabilities at FRIB. For the preparation of ion sources for the ReA, a high isotopic purity is not necessary and the chemically purified radioactive solutions can be used directly, without a preceding mass separation step. The experience acquired with the neutron reaction targets will be directly translatable towards the manufacturing of ReA ion sources. 📌



**Development of the mass separation capability by using the on-site available ReA facility. In the Batch Mode Ion Source (BMIS) the introduced sample will be ionized, followed by extraction and separation in the mass separator. A single ion beam will be selected and implanted into a collector foil, placed inside the collection system.**

### SELECTED PUBLICATIONS

*Harvesting krypton isotopes from the off-gas of an irradiated water target to generate  $^{76}\text{Br}$  and  $^{77}\text{Br}$* , Clause H.K., Domnanich K.A., Kleinfeldt C., Kalman M., Walker W., Vyas C., Abel E.P., Severin G.W., *Sci. Rep.* **2022**, 12, 1433.

*Harvesting  $^{62}\text{Zn}$  from an aqueous cocktail at the NSCL*, Domnanich K.A., Vyas C.K., Abel E.P., Kalman C., Walker W., Severin G.W., *New J. Chem.* **2020**, 44, 20861-20870.

*Durability test of a flowing-water target for isotope harvesting*, Abel E.P., Domnanich K.A., Kalman C., Walker W., Engle J.W., Barnhart T.E., Severin G., *Nucl. Instruments Methods Phys. Res. B* **2020**, 478, 34-45.

*Production and separation of  $^{43}\text{Sc}$  for radio-pharmaceutical purposes*, Domnanich K.A., Eichler R., Müller C., Jordi S., Yakusheva V., Braccini S., Behe M., Schibli R., Türlér A., van der Meulen N.P., *EJNMMI Radiopharm. Chem.* **2017**, 2, 14.

*$^{43}\text{Sc}$  as useful  $\beta$ -emitter for the radiotheragnostic paradigm: a comparative study of feasible production routes*, Domnanich K.A., Müller C., Benešová M., Dressler R., Haller S., Köster U., Ponsard B., Schibli R., Türlér A., van der Meulen N.P., *EJNMMI Radiopharm. Chem.* **2017**, 2, 5.

*Cyclotron production of  $^{44}\text{Sc}$ : From bench to bedside*, Van der Meulen N.P., Bunka M., Domnanich K.A., Müller C., Haller S., Vermeulen C., Türlér A., Schibli R., *Nuc Med Biol.* **2015** 42, 745-751.



**Karen Draths**

## Sustainable Synthesis, Organic Chemistry, Synthetic Biology

### ASSISTANT PROFESSOR

B.S.,  
Saint Mary's College;  
Ph.D.,  
Stanford Univ.;  
American Cancer Soc. Fellow,  
California Institute of Technology;  
Research Assistant Prof.,  
Michigan State Univ.;  
Co-founder, Senior Scientist and  
President,  
Draths Corporation;  
Assistant Prof.,  
Michigan State Univ.

517-353-0499



Research in the Draths lab focuses on creating **sustainable synthesis** methods for organic chemical production by combining **organic chemistry** and **synthetic biology**. Our projects encompass creation of new metabolic pathways, construction of microbial chassis to express these pathways, and microbial synthesis of targeted chemicals under controlled culture conditions. An iterative approach to catalyst design enables evaluation of the feasibility and techno-economics of new methods for large-scale commodity and specialty pharmaceutical applications. Organic chemistry and catalysis are pivotal for feedstock synthesis and diversification of chemical products.

In one application, methods are being devised to convert the two most abundant and harmful greenhouse gases — CO<sub>2</sub> and CH<sub>4</sub> — into alternative starting materials for commodity chemical production to reduce reliance on petroleum and biomass-derived feedstocks. Catalytic strategies that ultimately transform CO<sub>2</sub> and CH<sub>4</sub> into versatile building blocks are being examined. We rely on traditional organic and organometallic catalysis and enzyme-catalyzed transformations. In the realm of enzyme catalysis, we discover new enzymes, study structure-function relationships via x-ray crystallography, and evolve enzymes to improve catalytic characteristics. In a second application, carbohydrates obtained via anaerobic digestion from *waste organic matter* (corn stover, food waste, animal manure) are transformed into a valuable chiral synthon by microbes designed to use mixed carbohydrate feeds.

Researchers are exposed to and train in a variety of disciplines including organic synthesis/catalysis, analytical methods, molecular biological techniques, enzyme characterization and evolution, protein structure/function characterization, and bioreactor engineering. Our lab works with multiple collaborators to deepen the expertise applied to the research. We welcome researchers at all experience levels who are passionate about research and committed to addressing societal grand challenges. 🌱

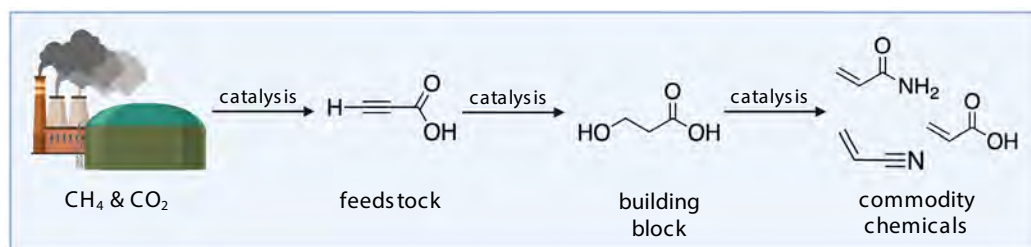
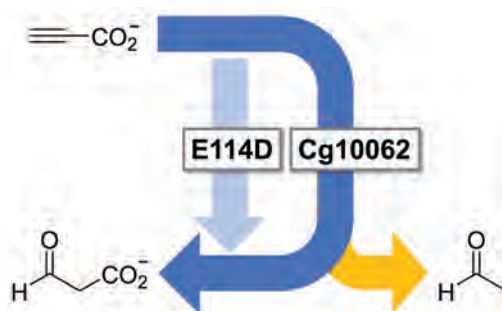
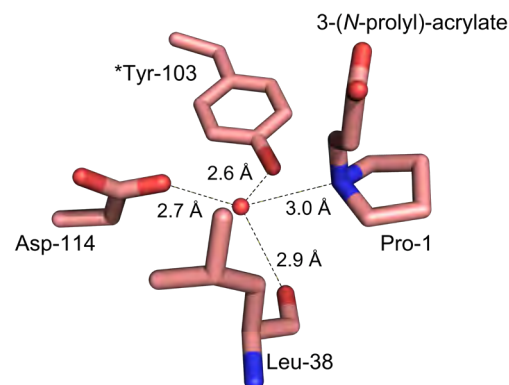
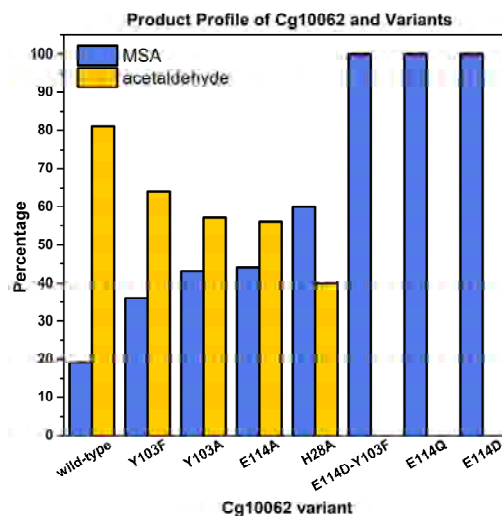
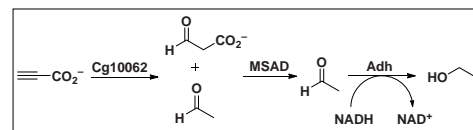
### SELECTED PUBLICATIONS

*Cg10062 Catalysis Forges a Link Between Acetylenecarboxylic Acid and Bacterial Metabolism*, Mathes Hewage, A.; Nayebi Gavvani, H.; Chi, D.; Qiu, B.; Geiger, J.H.; Draths, K., *Biochemistry* **2021**, *60*, 3879-3886.

*Characterization of two 3-deoxy-D-Arabino-Heptulosonate 7-phosphate synthases from Bacillus methanolicus*, Gruenberg, M.; Irla, M.; Myllek, S.; Draths, K., *Protein Expr. Purif.* **2021**, *188*, 105972.

*A promising new paradigm for performance-advantaged nylon sourced from β-ketoadipic acid*, Jadidi, Y.; Mathes Hewage, A.; Draths, K., *Chem Catalysis* **2022**, *2*, 664-66.

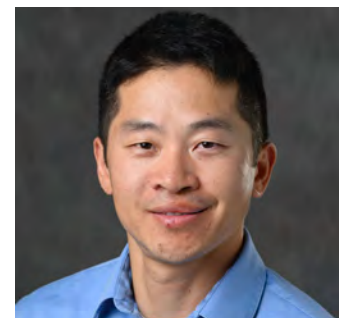
*Synthesis of 3-Hydroxypropionic Acid via Hydration of Acetylenecarboxylic Acid*, Draths, K.; Geiger, J.H.; Mathes Hewage, A.N.S.; Nayebi Gavvani, H., *U.S. Pat. Appl.* 025756, **2022**.



Positron emission tomography (PET) is a powerful imaging tool for visualization and quantification of cellular and molecular processes in live animals and in humans as well. PET is a technique that relies on radiotracers bearing positron emitters that decay inside the body of studied subjects. Thus radiotracers are essential for the success of PET imaging. My research interests focus on development of carbon-11 and fluorine-18 labeled radiotracers for imaging of cancer diseases, brain disorders and cardiovascular illnesses using PET. These developed radiotracers are employed in both preclinical and clinical research for disease diagnosis, treatment assessment, surgery evaluation and drug development. Tracer development is an interdisciplinary process including to select a target, to design the radiotracers of the target, to synthesize the radiotracers, to evaluate the tracers in vitro and in vivo, with the information to optimize the structures and labeling positions of the radiotracer, to select promising candidates to be synthesized by an automated synthesis module, and to translate the radiotracers to clinical trials. Chemistry is indispensable in the process, expertise of such chemical fields are involved: organic synthesis, medicinal chemistry, radiopharmaceutical chemistry etc. Analytical chemistry also plays a critical role for the purification and quality

control of radiotracers. Equipment includes but not limited to HPLC, Mass Spectrometry, Gas Chromatography, and Gamma Spectrometry. Moreover, the developmental process also involves in vitro evaluation of radiotracers with proteins and cells, in vivo validation with animals such as rodents and nonhuman primates, and translation to clinical studies. In addition to PET imaging, I am also interested in radioimmunotherapy, such as targeted alpha-therapy of different types of cancer, using alpha emitter lead-212 labeled monoclonal antibodies.

**Development of PDE10A radiotracers for imaging the enzyme in tumors and to support the development of anticancer drugs targeting PDE10A in colon, lung and breast tumors** – PDE10A has been mostly studied as a therapeutic target for certain psychiatric and neurological conditions. Recently, it has been reported that PDE10A is overexpressed in certain colon, lung and breast tumors, and the inhibition of PDE10A in tumor show promising anticancer effects; however, the role of PDE10A in tumor is barely studied. The overall goal is to radiolabel a highly potent and selective PDE10A PET radiotracer for PET imaging of tumor overexpressed PDE10A in animal models. ☺



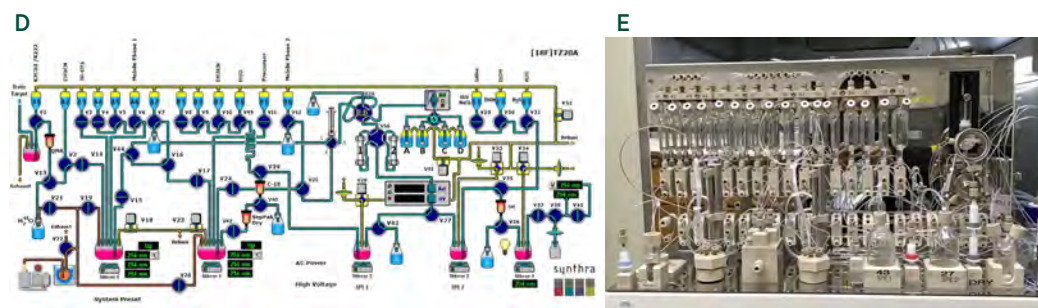
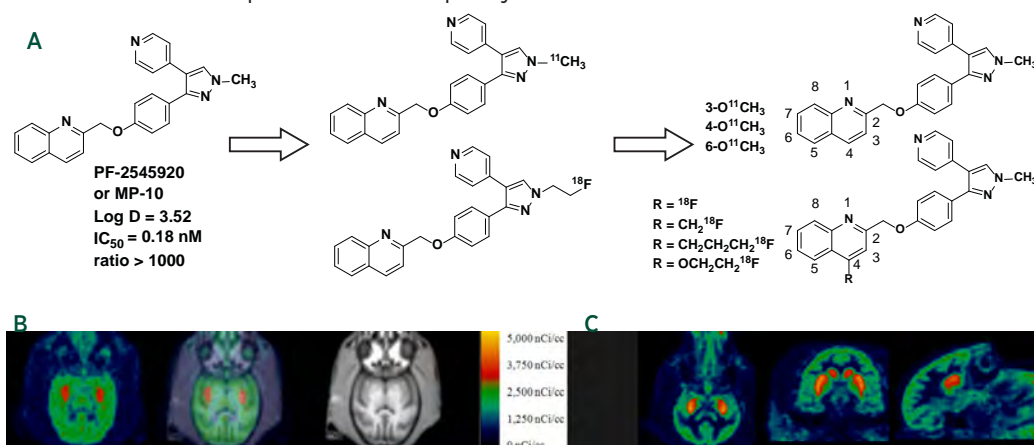
**Jinda Fan**

## Radiochemistry and Radiotracer Development for PET Imaging

ASSISTANT PROFESSOR  
AND  
ASSISTANT PROFESSOR OF  
RADIOLOGY

B.S.,  
East China Univ. of Science and Technology;  
Ph.D.,  
Southern Illinois Univ.  
Postdoctoral Scholar, Radiology,  
Washington Univ. in St. Louis;  
Staff Scientist, Radiology,  
Washington Univ. in St. Louis;  
Assistant Professor of Radiology,  
Univ. of Alabama at Birmingham.

517-353-0502



**A)** A scheme demonstrates the development of <sup>18</sup>F and <sup>11</sup>C PET radiotracers for PDE10A, from MP-10, a potent and highly selective PDE10A inhibitor, the first generation of tracers were labeled on the pyrazole moiety, and to improve metabolic stability, the second generation tracers were labeled on the quinoline. **B)** PET imaging results of Rhesus monkeys using [<sup>11</sup>C]MP-10, a representative summed image from 0 to 120 min is overlay with MRI images to accurately identify the regions of interest, caudate and putamen. **C)** Representative summed image of [<sup>18</sup>F]FEMP-10, axial, coronal, and sagittal images of a monkey's brain. **D)** A program chart displays the work flow on an automated synthesis module. **E)** A picture of the synthesis module, on which the radiolabeling synthesis is conducted.

### SELECTED PUBLICATIONS

*Radiosyntheses and in vivo evaluation of carbon-11 PET tracers for PDE10A in the brain of rodent and nonhuman primate*, Fan J, Zhang X, Li J, Jin H, Padakanti PK, Jones LA, Flores HP, Su Y, Perlmutter JS, Tu Z. *Bioorg. Med. Chem.* **2014**, 22(9), 2648-54.

*Synthesis of Fluorine-Containing Phosphodiesterase 10A (PDE10A) Inhibitors and the In Vivo Evaluation of F-18 Labeled PDE10A PET Tracers in Rodent and Nonhuman Primate*, Li J, Zhang X, Jin H, Fan J, Flores H, Perlmutter JS, Tu Z, *J. Med. Chem.* **2015**, 58(21), 8584-8600.

*<sup>212</sup>Pb-labeled B7-H3-targeting antibody for pancreatic cancer therapy in mouse models*, Kasten BB, Gangrade A, Kim H, Fan J, Ferrone S, Ferrone CR, Zinn KR, Buchsbaum DJ., *Nucl. Med. Biol.* **2018**, 58, 67-73.



**Joseph J. Gair**

## Selective Catalysis, Organic, Organometallic

### ASSISTANT PROFESSOR

B.A.,  
Saint John's University;  
Ph.D.,  
Univ. of Chicago;  
Medicinal Chemist,  
Vertex Pharmaceuticals;  
Postdoctoral Fellow,  
Harvard Univ.  
Principal Scientist 2,  
Merck.

517-355-9715



### SELECTED PUBLICATIONS

*Insight into the Scope and Mechanism for Transmetalation of Hydrocarbyl Ligands on Complexes Relevant to C-H Activation*, Chan, N.H.; Gair J.J.; Roy, M.; Qiu, Y.; Wang, D.-S.; Durak, L.J.; Chen, L.; Filatov, A.S.; Lewis, J.C., *Organometallics* **2021**, 40 (1), 6-10.

*Palladium-Catalyzed Hydrodefluorination of Fluoroarenes*, Gair, J.J.; Grey, R.L.; Giroux, S.; Brodney, M.A., *Org. Synth.* **2021**, 98, 131-146.

*Catalytic Behavior of Mono-N-Protected Amino Acid Ligands in Ligand-Accelerated C-H Activation by Palladium(II)*, Salazar, C.A.; Gair, J.J.; Flesch, K.N.; Guzei, I.A.; Lewis, J.C.; Stahl, S.S., *Angew. Chem. Int. Ed.* **2020**, 59, 10873-10878.

*Di-Palladium Complexes are Active Catalysts for Mono-N-Protected Amino Acid-Accelerated Enantioselective C-H Functionalization*, Gair, J.J.; Haines, B. E.; Filatov, A. S.; Musaev, D.G.; Lewis, J.C., *ACS Catalysis* **2019**, 9, 11386-11397.

*Palladium Catalyzed Hydrodefluorination of Fluoro-(hetero)arenes*, Gair, J.J.; Grey, R.L.; Giroux, S.; Brodney, M.A., *Organic Letters* **2019**, 21, 2482-2487.

*Synthesis, Characterization, and Theoretical Investigation of a Transition State Analogue for Proton Transfer during C-H Activation by a Rhodium-Pincer Complex*, Gair, J.J.; Qiu, Y.; Khade, R.L.; Chan, N.H.; Filatov, A.S.; Zhang, Y.; Lewis, J.C., *Organometallics* **2019**, 38 (7), 1407-1412.

*Rhodium Complexes of 2,6-bis(dialkylphosphinomethyl)pyridines: Improved C-H Activation, Expanded Reaction Scope, and Catalytic Direct Arylation*, Gair, J.J.; Qiu, Y.; Chan, N. H.; Filatov, A.S.; Lewis, J. C., *Organometallics* **2017**, 36 (24), 4699-4706.

*Mono-N-Protected Amino Acid Ligands Stabilize Dimeric Palladium(II) Complexes of Importance to C-H Functionalization*, Gair, J.J.; Haines, B.E.; Filatov, A.S.; Musaev, D.G.; Lewis, J.C., *Chem. Sci.* **2017**, 8 (8), 5746-5756.

The Gair group is focused on the invention and application of synthetic methods that fine-tune structural motifs prevalent in drug discovery and catalyst design. Tools to tailor the cores of these scaffolds will streamline access to highly valued analogs and ultimately accelerate the discovery of new function across the molecular sciences.

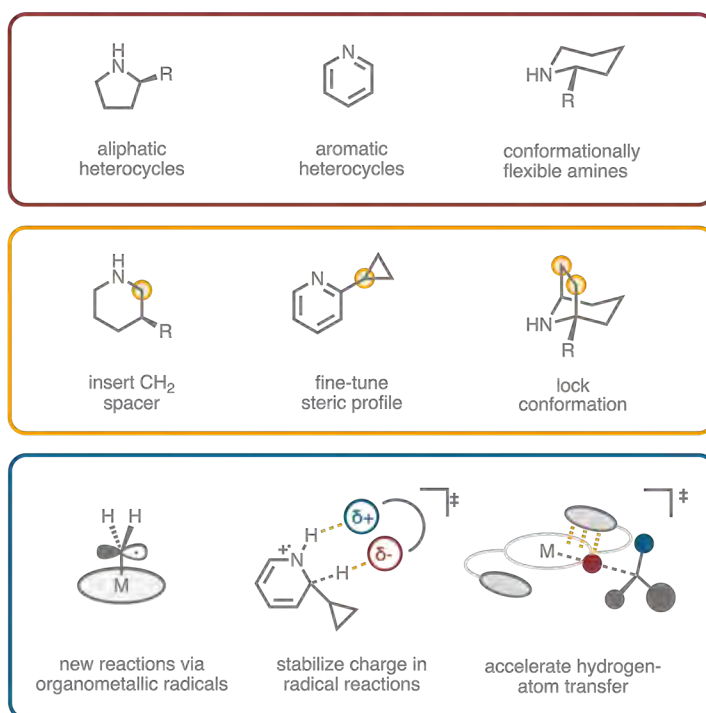
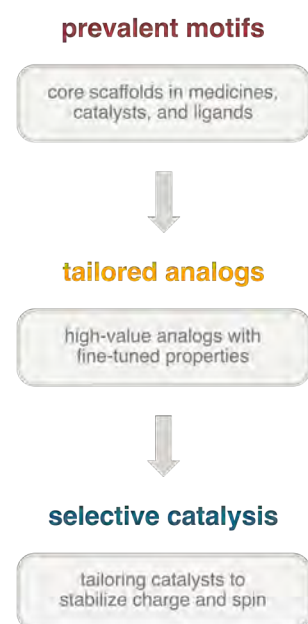
**Tailoring Molecules** – Subtle alterations to a molecule's structure often yield profound changes in function. A striking illustration of this phenomenon can be seen in what has been dubbed the "magic methyl effect", whereby replacing a hydrogen with a methyl group in a complex molecule can dramatically improve the potency of drugs. Given this sensitive balance between structure and function, the discovery of new medicines relies on access to fine-tuned analogs of lead scaffolds. The most important of these analogs are those that preserve the functional groups of the parent molecule while subtly adjusting the shape of the core scaffold. At present, these analogs are prepared via lengthy synthesis from modified starting materials or entirely redesigned routes.

Inspired by the imagery of a tailor altering a garment to achieve a perfect fit, the Gair group aims to develop synthetic tools to tailor molecules. We are targeting transformations that fine-tune the shape of lead scaffolds without perturbing the functional groups that engender function. Our strategy is to develop new reactions that engage heterocycles and amines because these motifs are abundant

across several important classes of functional molecules including medicines, biological probes, organocatalysts, and ligands. With these tools we aim to streamline access to custom-fit analogs and thereby accelerate discovery of new function across the molecular sciences.

**Selective Catalysis** – In addition to the practical applications outlined above, reaction development in the Gair group is centered on designing catalysts that engage in attractive interactions with transition states featuring unpaired electrons (open-shell) to achieve novel reactivity and selectivity (chemo, site, and stereo selectivity). One project area is focused on electronic tuning of organometallic radicals to achieve diverse  $\text{CH}_2$  insertion reactions with chemoselectivity dictated by the electronic structure of the catalyst. A second project area involves designing organocatalysts that complement the electrostatic topology of proton-transfer transition states to control site selectivity in radical alkylation of heteroarenes. The final project area aims to engineer hydrogen-bond acceptors on ligands of hydrogen-atom transfer catalysts to achieve enantioselective C-H functionalization. By studying the relationship between catalyst structure, rate, and selectivity in these transformations, we aim to decode the nature of attractive interactions between catalysts and open-shell transition states. Ultimately, we will apply these insights to design new catalysts for tailoring molecules and optimization of molecular function at large. 🍀

### tailoring molecules to optimize function



The Gaiser group's focus will be on benefiting society through both the study of relevant radiotherapy isotopes for medical use and the study of *f*-block elements targeting the energy crisis and better storage of spent nuclear fuel.

Radium will be a main target within the relevant radiotherapy isotopes. Despite radium being an FDA-approved targeted alpha therapy treatment for bone metastasized cancers, there is a significant dearth of information surrounding its structure and bonding. Developing the fundamental chemistry of radium through determining its preferred coordination and bonding environment will guide the intelligent design of a chelating system constructed for radium. A chelator specific to radium would allow biological targeting outside of where radium naturally accumulates — in the bones; thus, being able to target cancers beyond bone metastasized cancers. The Gaiser group's goal to study radium in both the solid and solution states will elucidate these unknowns of radium, which have yet to be determined due to radium's high radioactivity and daughter product of gaseous radon. The vast experience working with radioactive material of the Gaiser Group and the safety guidelines Michigan State University has in place allows for this research to be safely performed. Together, through synthesis and characterization of various radium complexes, a targeted chelating system may be designed and employed to direct radium to other parts of the body as opposed to where it naturally accumulates, in the bones.

The beam dump at FRIB will constantly be generating promethium-147. This isotope has not only shown promise as a PET imaging and beta-therapy isotope, but also within nuclear batteries as a nonthermal converter. Through optimizing the purification of promethium from the beam dump, promethium may be

isolated to begin to understand the chemistry of this exclusively radioactive lanthanide. The isolation of promethium may be beneficial toward a future of commercializing promethium batteries. Promethium-147 is a choice option as a nonthermal converter as it decays purely through beta emission and has extremely low intensity gamma lines, all easily shielded within a battery. Additionally, since promethium is the only exclusively radioactive lanthanide, there is a deep lack of knowledge surrounding its chemistry particularly compared to the rest of the lanthanides. There are many examples of trends within the lanthanide series, where missing the experiment with promethium results in a rather large gap. The isolation of promethium will allow for its fundamental chemistry to be developed, these gaps in lanthanide trends to be filled, and potentially other uses discovered. Furthermore, the foundation of promethium purification, mainly from its neighboring lanthanides—neodymium and samarium—may shed light on their actinide size analogs—americium and curium. Establishing a reliable separation of americium and curium on an industrial scale continues to be one of the larger challenges facing the cleanup and storage of spent nuclear fuel; therefore, targeting the separation of promethium without manipulating oxidation state may also aid in solving the americium and curium separation issue. ↕



**Alyssa Gaiser**

**Radiochemistry**

**ASSISTANT PROFESSOR**

Ph.D.,  
Florida State University;  
B.S.,  
Univ. of California, Los Angeles.  
Postdoctoral Fellow,  
Univ. of California, Berkeley.



517-355-9715

#### SELECTED PUBLICATIONS

*Creation of an unexpected plane of enhanced covalency in cerium(III) and berkelium(III) terpyridyl complexes*, A.N. Gaiser, C. Celis-Barros, F.D. White, M.J. Beltran-Leiva, J.M. Sperling, S.R. Salpage, T.N. Poe, D. Gomez Martinez, T. Jian, N.J. Wolford, N.J. Jones, A.J. Ritz, R.A. Lazenby, J.K. Gibson, R.E. Baumbach, D. Páez-Hernández, M.L. Neidig, T.E. Albrecht-Schönzart, *Nat. Commun.* **2021**, 12(1), 7230.

*Examination of Structure and Bonding in 10-Coordinate Europium and Americium Terpyridyl Complexes*, White, F.D.; Gaiser, A.N.; Warzecha, E.J.; Sperling, J.M.; Celis-Barros, C.; Salpage, S.R.; Zhou, Y.; Dilbeck, T.; Bretton, A.J.; Meeker, D.S.; Hanson, K.G.; Albrecht-Schmitt, T.E., *Inorg. Chem.* **2018**, 57 (20). <https://doi.org/10.1021/acs.inorgchem.8b02085>.

*Structural and Spectroscopic Investigation of Two Plutonium Mollitates*, Sperling, J. M.; Gaiser, A.N.; Windorff, C.J.; Klamm, B.E.; Whitefoot, M.A.; Chemey, A.T.; Long, B.N.; Campbell, J.G.; Albrecht-Schmitt, T.E., *Inorg. Chem.* **2020**, 59 (5), 3085. <https://doi.org/10.1021/acs.inorgchem.9b03432>.

*Compression of Curium Pyrrolidine-Dithiocarbamate Enhances Covalency*, Sperling, J.M.; Warzecha, E.J.; Celis-Barros, C.; Sergentu, D.C.; Wang, X.; Klamm, B.E.; Windorff, C.J.; Gaiser, A.N.; White, F.D.; Beery, D.A.; Chemey, A.T.; Whitefoot, M.A.; Long, B.N.; Hanson, K.; Kögerler, P.; Speldrich, M.; Zurek, E.; Autschbach, J.; Albrecht-Schönzart, T.E., *Nature* **2020**, 583 (7816), 396. <https://doi.org/10.1038/s41586-020-2479-2>.



**James H. Geiger**

## Structural Biology Using X-ray Crystallography

### PROFESSOR

B.S.,  
New College of USF (Florida);  
Ph.D.,  
Princeton Univ.;  
American Cancer Society Postdoctoral  
Fellow,  
Yale Univ.;  
Postdoctoral Fellow,  
Yale Univ.

517-353-1144



### SELECTED PUBLICATIONS

*A Photoisomerizing Rhodopsin Mimic Observed at Atomic Resolution*, Nosrati, M., Berbasova, T., Vasileiou, C., et al., *J. Am. Chem. Soc.* **2016**, *138*, 8802-8808.

*Crystal structures of Escherichia coli branching enzyme in complex with cyclodextrins*, Feng, L., Fawaz, R., Hovde, S., et al., *Acta Crystallographica Section D-Structural Biology* **2016**, *72*, 641-647.

*Domain-Swapped Dimers of Intracellular Lipid-Binding Proteins: Evidence for Ordered Folding Intermediates*, Assar, Z., Nossioni, Z., Wang, W., et al., *Structure* **2016**, *24*, 1590-1598.

*Stereochemistry and Mechanism of a Microbial Phenylalanine Aminomutase*, Ratnayake, N. D.; Wanninayake, U.; Geiger, J. H.; Walker, K. D., *J. Am. Chem. Soc.* **2011**, *133* (22), 8531-8533.

*"Turn-On" Protein Fluorescence: In Situ Formation of Cyanine Dyes*, Yapici, I., Lee, K. S. S., Berbasova, T., et al., *J. Am. Chem. Soc.* **2015**, *137*, 1073-1080.

*Kinetically and Crystallographically Guided Mutations of a Benzoate CoA Ligase (BadA) Elucidate Mechanism and Expand Substrate Permissivity*, Thornburg, C. K., Wortas-Strom, S., Nosrati, M., et al., *Biochemistry* **2015**, *54*, 6230-6242.

*Tuning the Electronic Absorption of Protein-Embedded All-trans-Retinal*, Wang, W., Nossioni, Z., Berbasova, T., et al., *Science* **2012**, *338*, 1340-1343.

*Insights into the Mechanistic Pathway of the Pantoea agglomerans Phenylalanine Aminomutase*, Strom, S., Wanninayake, U., Ratnayake, N. D., et al., *Angew. Chem.-Int. Ed.* **2012**, *51*, 2898-2902.

*Light-Activated Reversible Imine Isomerization: Towards a Photochromic Protein Switch*, Berbasova, T., Santos, E. M., Nosrati, M., et al., *ChemBiochem* **2016**, *17*, 407-414.

The major focus of our research is to both understand and engineer proteins and protein complexes at atomic resolution. This allows us to both think about and manipulate these large molecular systems chemically, with an emphasis on how the atomic resolution structural details of the systems give rise to their properties, activities and function.

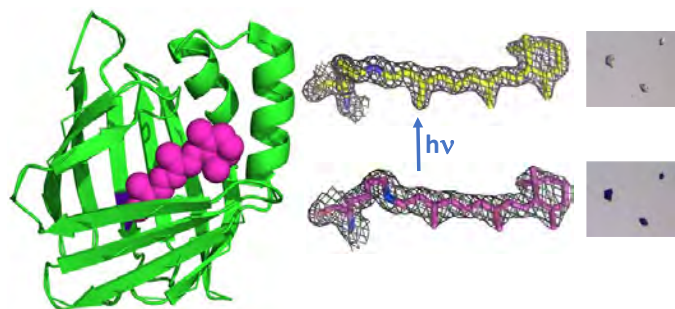
**Structure and Mechanism of Enzymes** - We have determined the structures of all three of the enzymes in the starch biosynthetic pathway, ADP-glucose pyrophosphorylase, Branching enzyme and glycogen/starch synthase. Our structures of glycogen synthase and branching enzyme showed for the first time that several glycogen binding sites exist outside the enzyme's active site. They are important for the enzyme's activity and understanding their role is a focus of our future work. More recently we have determined a structure of rice Branching enzyme bound to maltododecaside, which unveiled the trajectory of the glucans that react. We now understand the determinants of substrate specificity for this, and essentially all the other branching enzymes. This allows us to start thinking about how to predict the reactivity of these enzymes from their sequence. In collaboration with the Walker lab, we have also investigated the structure, mechanism and specificity of some of the enzymes involved in Taxol biosynthesis, including phenylalanine aminomutase (PAM) and benzoic acid CoA ligase. The structures of 2 PAMs have been determined, and a variety of benzoic acid CoA ligase substrate structures have been determined for use in rationally extending the substrate specificity of these enzymes.

**Visualizing rhodopsin mimics at atomic resolution** - In collaboration with the Borhan lab, we redesigned small cytosolic proteins (cellular retinoic acid binding protein II (hCRABPII) and cellular retinol binding protein II (hCRBPPII) to be rhodopsin mimics that form a protonated Schiff base with the retinal chromophore. Further, we constructed a spectrum of protein pigments that bind the same chromophore retinal, but alter the absorbance of this chromophore

over 219 nm. We have also developed new fluorescent proteins that can be used as fluorescent protein fusion tags, extending the range of fluorescent proteins and adding pH sensing to their repertoire. More recently we have turned our attention to understanding the photoisomerization process. To this end we have engineered retinal-bound protein variants that specifically photo-isomerize only one of the five double bonds in the chromophore. So far we have variants that specifically isomerize either the imine bond or the 13-bond, the latter of which is the very same bond isomerized in all bacterial rhodopsins. Further, we observe these isomerizations in single crystals, at atomic resolution. We are now pursuing time-resolved crystallographic experiments on these species to visualize the intermediates in the photo-isomerization process. There are very few systems that lend themselves to the difficult techniques of time resolved crystallography and our model systems are ideal candidates. The ability to design from scratch protein/chromophore systems that work so spectacularly open the door to creating completely novel photo-active proteins for a wide variety of potential applications.

### Engineering domain swapped dimers and the creation of new allosteric proteins

- We have recently discovered that variants of hCRBPPII readily and irreversibly fold into domain swapped dimers (DS dimers). A DS dimer forms when identical elements of structure swap places in two monomers to form a dimeric structure. After characterizing some of the determinants of DS dimer formation, so that we can control its formation, we discovered that ligand binding induces a dramatic conformational change in the DS dimer. A variety of ligands illicit the conformational change, including retinal, fatty acids and some fluorophores. We are currently using the DS dimer to create new allosteric proteins that can be controlled by redox state, ligand or metal binding depending on our design. Previous efforts at allosteric protein design use naturally occurring allosteric proteins to control other processes. This is one of the few cases where an allosteric protein is engineered "from scratch." ☘

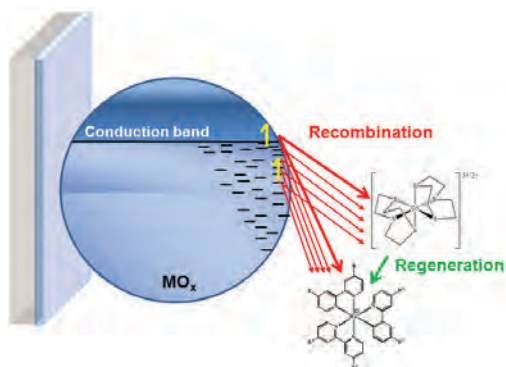


Left, The structure of a retinal-bound hCRABPII variant. Right, pictures of crystals of an hCRABPII variant before (top) and after (bottom) UV irradiation. Center, the electron density map of retinal bound to an hCRABPII variant before (top) and after (bottom) irradiation with UV light showing specific photoisomerization in the single crystal that gives rise to the color change.



**Hamann Group Research** – The Hamann group is engaged in interdisciplinary research to address basic science issues related to new methods, molecules and materials to convert solar energy to electricity and chemical fuels. Of specific interest are regenerative and non-regenerative photoelectrochemical cells, including dye-sensitized solar cells and thin-film absorber photoelectrocatalytic systems. In addition, we are interested in the use of ammonia as an energy (hydrogen) carrier and are investigating electrocatalytic nitrogen fixation and ammonia splitting.

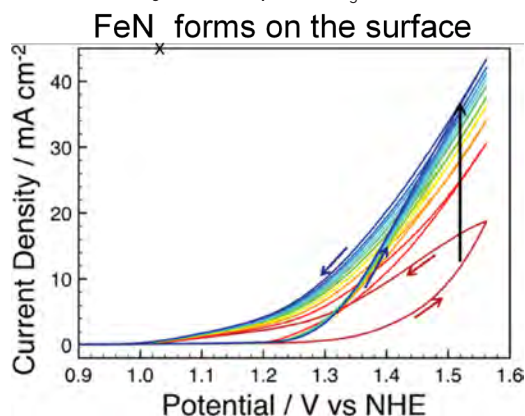
**Dye Sensitized Solar Cells** – Ultra-fast electron injection from a photoexcited sensitizer into a photoanode produces a charge separated state with typically high quantum efficiency. We are primarily interested in the subsequent processes of dye regeneration and recombination which control the efficiency of charge collection. We systematically vary the components involved in each reaction and interrogate them with a series of photoelectrochemical measurements. The general lessons learned will ultimately be used to develop design rules for next



generation DSSCs comprised of molecules and materials which can overcome the kinetic and energetic constraints of current generation cells. In addition, we are investigating new related paradigms of solar energy conversion based on the knowledge gained from more conventional systems.

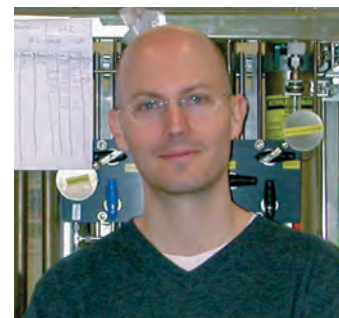
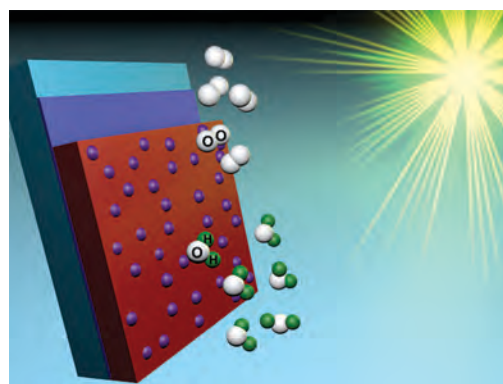
**Thin Film Absorber Solar Cells** – We are interested in exploring the use of thin film semiconductors to drive photoelectrochemical water splitting (solar fuel-forming) reactions. We are currently elucidating the rate limiting steps as well as water oxidation mechanism on the electrode surface. Additional topics of recent interest include understanding the effect of substrate and underlayer materials, incorporation of dopants, and surface layers (e.g. catalysts) on the water oxidation efficiency. Additional oxide, nitride and oxynitride semiconductor materials are also under current investigation.

**Ammonia Electrocatalysis** – Nitrogen is the most abundant gas in Earth's atmosphere and water is the most abundant liquid on Earth's surface; combining the catalytic reduction of  $N_2$  with the oxidation of  $H_2O$  to produce  $NH_3$  offers a route to scalable renewable energy storage. Liquid ammonia has an energy density comparable to methanol, and the stored chemical energy can in principle be used to generate electricity or  $H_2$  on demand. The electrolysis of liquid  $NH_3$  has received



limited attention to date, however. We are also engaged on a broader collaborative effort with the Smith group to investigate the electrocatalytic conversion of liquid  $NH_3$  to  $H_2$ . In addition, we are developing new electrocatalysts based on earth-abundant materials for  $NH_3$  synthesis and electrolysis.

<https://hamanngroup.weebly.com/>



**Thomas W. Hamann**

## Inorganic Materials / Electrochemistry

**JAMES L. DYE ENDOWED CHAIR**  
AND  
**PROFESSOR**

B.A.,  
Univ. of Texas;

M.S.,  
Univ. of Massachusetts;

Ph.D.,  
California Institute of Technology;

Postdoctoral Fellow,  
Northwestern Univ.



517-353-1072

### SELECTED PUBLICATIONS

*Low-Spin Cobalt(II) Redox Shuttle by Isocyanide Coordination*, Raithel, A.L., Kim, T.Y., Nielsen, K., Staples, R.J., Hamann, T.W.; *Sust. Energy & Fuels* **2020**, *4*, 2497-2507. DOI: 10.1039/DO5E00314J

*Real-Time Observation of the Diffusion Mechanism Progression from Liquid to Solid-State of Transition Metal Complexes*, Kim, T.Y., Wang, Y., Raithel, A.L., Hamann, T.W., *ACS Energy Lett.* **2020**, *5*, 2, 583-588.

*Improved Performance Induced by in-situ Ligand Exchange Reactions of Copper Bipyridyl Redox Couples in Dye-Sensitized Solar Cells*, Wang, Y., Hamann, T.W., *Chem. Commun.* **2018**, *54*, 12361-12364.

*Charge-Carrier Dynamics at the CuWO<sub>4</sub>/Electrocatalyst Interface for Photoelectrochemical Water Oxidation*, Shadabipour, P., Raithel, A.L., Hamann, T.W., *ACS Appl. Materials & Interfaces* **2020**, *12*, 45, 50592-50599.

*Thin film photoelectrodes for solar water splitting*, He, Y., Hamann, T.W., Wang, D.; *Chemical Society Reviews* **2019**, *48*, 2182-2215.

*Determination of Photoelectrochemical Water Oxidation Intermediates on  $\alpha$ -Fe<sub>2</sub>O<sub>3</sub> Electrode Surfaces Employing Operando ATR-IR Spectroscopy*, Zandi, O., Hamann, T.W.; *Nature Chemistry* **2016**, *8*, 778-783.

*Recent Advances and Challenges of Electrocatalytic N<sub>2</sub> Reduction to Ammonia*, Qing, G., Ghazfar, R., Jackowski, S.T., Habibzadeh, F., Maleka Ashtiani, M., Chen, C. Smith, M.R., Hamann, T.W., *Chemical Reviews* **2020**, *120*, 12, 5437-5516.

*Homogeneous Electro-Catalytic Oxidation of Ammonia to N<sub>2</sub> Under Mild Conditions*, Habib-Zadeh, F., Miller, S.L., Hamann, T.W., Smith, M.R.; *Proc. Nat. Acad. Sci.* **2019**, *116* (8) 2849-2853.

*As Precious as Platinum: Iron Nitride for Electrocatalytic Oxidation of Liquid Ammonia*, Little, D.J., Edwards, D., Smith, M.R., Hamann, T.W.; *ACS Appl. Mat. & Interf.* **2017**, *9* (19), 16228-16235.



## Elad Harel

### Deep Spectroscopy for Breakthrough Molecular Discovery

#### ASSOCIATE PROFESSOR

B.S., B.A.,  
Univ. of California, San Diego;

Ph.D.,  
Univ. of California, Berkeley;

Postdoctoral Fellow,  
University of Chicago.

517-353-1078



#### SELECTED PUBLICATIONS

*Electronic Coherence Lifetimes of the Fenna-Matthews-Olson Complex and Light Harvesting II*, S. Irgen-Gioro, K. Gururangan, R. G. Saer, R. E. Blankenship, E. Harel, *Chem. Sci.* **2019**, 10.1039/C9SC03501J.

*Transient Sub-Band-Gap States at Grain Boundaries of CH<sub>3</sub>NH<sub>3</sub>PbI<sub>3</sub> Perovskite Act as Fast Temperature Relaxation Centers*, X. Jiang, J. Hoffman, C. C. Stoumpos, M. G. Kanatzidis, E. Harel, *ACS Energy Lett.* **2019**, 4, 1741-1747.

*Coherent and Dissipative Quantum Process Tensor Reconstruction in Two-Dimensional Electronic Spectroscopy*, K. Gururangan, E. Harel, *J. Chem. Phys.* **2019** 150, 164127.

*Four-Dimensional Spectroscopy of Complex Molecular Systems in Solution*, A. P. Spencer, E. Harel, *J. Phys. Chem. C* **2019**, 123, 6303 (cover article).

*Coherences of Bacteriochlorophyll a Uncovered Using 3D-Electronic Spectroscopy*, S. Irgen-Gioro, A. P. Spencer, W. O. Hutson, E. Harel, *J. Phys. Chem. Lett.* **2018**, 9, 6077-6081.

*Exciton-Phonon Spectroscopy of Quantum Dots Below the Single-Particle Homogeneous Linewidth*, A. P. Spencer, W. O. Hutson, S. Irgen-Gioro, E. Harel, *J. Phys. Chem. Lett.* **2018**, 9, 1503-1508.

*Zooming in on Vibronic Structure by Lowest-Value Projection Reconstruction 4D Coherent Spectroscopy*, E. Harel, *J. Chem. Phys.* **2018**, 148, 194201.

*Ultrafast Four-Dimensional Coherent Spectroscopy by Projection Reconstruction*, W. O. Hutson, A. P. Spencer, E. Harel, *J. Phys. Chem. Lett.* **2018**, 9, 1034.

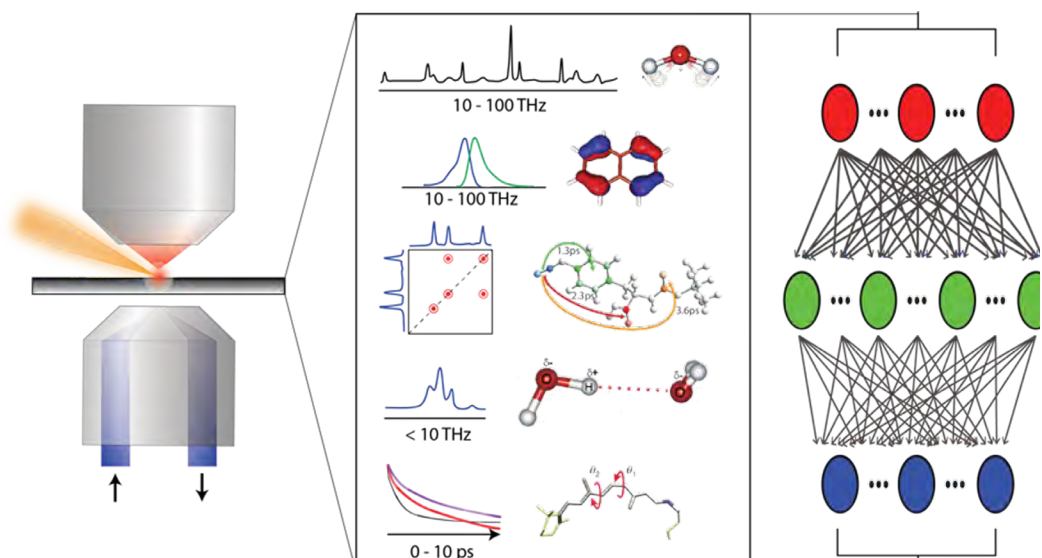
*Transient Sub-bandgap States in Halide Perovskite Thin Films*, S. Nah, B. M. Spokoynny, X. Jiang, C. M. M. Soe, C. C. Stoumpos, M. G. Kanatzidis, E. Harel, *Nano Lett.* **2018**, 18, 827-831.

*Ultrafast Imaging of Carrier Cooling in Metal Halide Perovskite Thin Films*, S. Nah, B. M. Spokoynny, C. M. M. Soe, C. C. Stoumpos, M. G. Kanatzidis, E. Harel, *Nano Lett.* **2018**, 18, 1044.

*Four-dimensional Coherent Electronic Raman Spectroscopy*, E. Harel, *J. Chem. Phys.* **2017**, 146, 154201.

Research in the Harel lab is aimed at using advanced ultrafast spectroscopic and imaging techniques for fundamental studies of complex chemical and biological systems. This approach leverages a deep understanding of how interactions at the molecule scale influence macroscopic observables in dynamical systems. These local changes may be, for example, disruptions in the intramolecular forces that hold a protein in its folded state, weak lattice phonons that scatter charge carriers in semiconductors, or light-induced electron transfer in photosynthetic organisms. A fundamental understanding of the connection between such microscopic interactions and their influence on macroscopic system properties in complex, condensed- or solid-phase environments is critical to informing the designs of next-generation catalysts,

resources. Deep learning approaches which have shown tremendous success in a wide range of fields from machine vision, gaming, defense, and health care to name a few, could lead to breakthrough discoveries, but only if high-quality and a sufficient volume of data was readily available. Our lab is developing tools to generate big data by combining high-throughput synthesis, rapid nonlinear optical characterization, and deep-learning-based modeling. Recent efforts have been aimed at combining high-resolution scanning probe microscopy for morphology analysis with ultrafast spectroscopy (e.g. ultrafast pump-probe, 2D/3D/4D coherent spectroscopy) to gain insight into the chemical composition and electron dynamics at the nanometer length scale. Using high-throughput robotic synthesis, we are able to rapidly synthesize

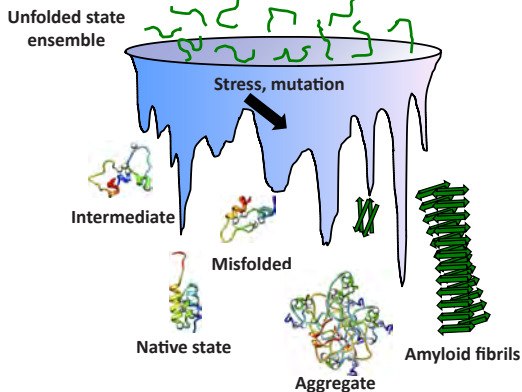


**In-situ microscopy combined with various single-molecule and ensemble spectroscopies (THz, 2D, pump-probe, TR-PL, etc.) is used to generate high-quality data for deep learning.**

new small-molecule drugs, and novel optical materials with tailored functionality. However, as the systems becoming increasingly complex, understanding the myriad of factors that dictate function of a molecule or performance of a system becomes too convoluted to uncover by conventional approaches. This is one of the main reasons that breakthrough molecular and materials discoveries are largely serendipitous. A big data approach to these challenges could quickly inform on the cause and effect of chemical and physical changes across a vast phase space that is too large to search systematically even with the help of state-of-the-art computational

and analyze thousands of different materials in a fraction of the time of conventional approaches using a miniscule amount of material. By combining ensemble and single-molecule approaches, we can gather data across vast regions of temporal, spectral, and spatial scales which inform on critical factors that dictate the function and performance of systems rather than just compounds. Current molecular targets include conjugated polymers used in organic photovoltaics, singlet fission materials, light-harvesting pigment-protein complexes, colloidal quantum dots, and two- and three-dimensional halide perovskite materials. 🌱

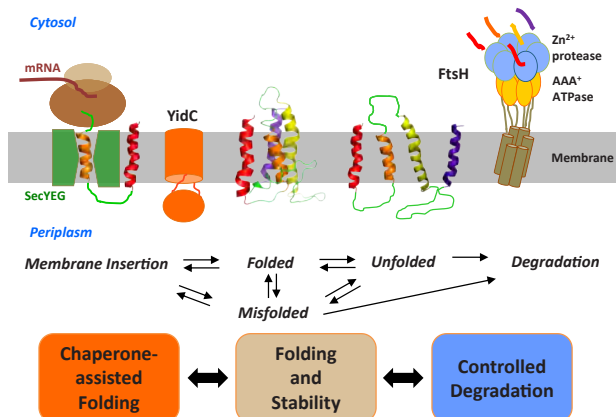
Protein folding is an amazing molecular process that occurs by sorting out an astronomical number of possible conformations down the free energy landscape. In a crowded cellular environment, however, environmental stresses or mutations can mislead polypeptide chains to misfolded or catastrophic aggregate states (Fig. 1). Therefore, these unnecessary proteins have



**Fig. 1. Ruggedness of free-energy landscape in protein folding (modified from Hartl et al., Nature 2011, 475, 324-332.)**

to be selectively cleared from cells for quality control and regulatory purposes. For the past decades, there have been remarkable advances in understanding these phenomena and related diseases. However, efforts have been largely limited to water-soluble proteins excluding the other major class of proteins that reside in cell membranes.

Our research focuses on a fundamental biological question, how membrane proteins are made and destroyed in cells (Fig. 2). Membrane proteins comprise approximately 30% of all proteins encoded in genes and carry out numerous critical cellular functions. Approximately 60% of all drug developments target membrane proteins. The folding problem of membrane proteins is directly connected to human health. Indeed, accumulation of misfolded or misprocessed membrane proteins causes serious diseases such as Alzheimer's disease, cystic fibrosis, and cancer. To answer



**Fig. 2. From the cradle to the grave: overall scheme of membrane protein research in the Hong lab.**

our cardinal question, we investigate two conceptually connected biological processes by multi-disciplinary approaches including biochemical, biophysical, and chemical methods.

**Chaperone-assisted membrane protein folding** – YidC/Oxa1/Alb3 is a membrane protein family that plays a critical role in folding and assembly of membrane proteins in the inner membranes of bacteria, mitochondria, and chloroplasts. In *E. coli*, YidC forms a membrane insertion pore independent of SecYEG complex, major protein translocation machinery. YidC also has a chaperone activity: it facilitates the folding of a variety of SecYEG-dependent proteins. To understand how YidC acts as chaperone, we will tackle three specific problems:

- What are the driving forces in YidC-substrate interaction?
- What mechanism does YidC use to facilitate folding of membrane proteins?
- How are the structure and dynamics of YidC related to the function?

**Controlled degradation of membrane proteins** – Rapid protein degradation is a crucial cellular process that enables the clearance of misfolded proteins and regulatory proteins that are no longer needed. In all cells, this process is mediated by AAA<sup>+</sup>-protease superfamily. FtsH is the only membrane-localized AAA<sup>+</sup>-protease, which degrades both membrane and cytosolic proteins. To understand the principles of the quality control mechanism of membrane proteins, we focus on three specific questions using FtsH from *E. coli* as model.

- What sequence or structural features of substrates are subject to degradation?
- What is the role of the FtsH trans-membrane domain in recognition and translocation of substrates?
- How is the proteolytic activity modulated by other membrane-bound cofactors?

Graduate students will gain a training opportunity in DNA manipulation, expression and purification of membrane proteins, biophysics of lipid bilayers, protein labeling, and various biophysical tools such as fluorescence, EPR, and X-ray crystallography.



## Heedeok Hong

### Biophysical Chemistry of Membrane Protein Folding and Degradation

#### ASSOCIATE PROFESSOR

B.S., M.S.,  
Yonsei Univ., South Korea;

Ph.D.,  
Univ. of Virginia;

Postdoctoral Fellow,  
Univ. of California, Los Angeles;

The Leukemia and Lymphoma Society  
Postdoctoral Fellowship

Board of Reviewing Editor,  
eLife.



517-353-1104

#### SELECTED PUBLICATIONS

*Lipid bilayer induces contraction of the denatured state ensemble of a helical-bundle membrane protein*, Gaffney, K.A., Guo, R., Bridges, M.D., Muhammednazaar, S., Chen, D., Kim, M., Yang, Z., Schillmiller, A.L., Faruk, N.F., Peng, X., Jones, A.D., Kim, K.H., Sun, L., Hubbell, W.L., Sosnick, T.R., and Hong, H., *Proc. Natl. Acad. Sci. USA* **2022**, 119, e2109169119.

*Untangling the complexity of membrane protein folding*, Hong H, Choi HK, and Yoon T.-Y, *Curr. Opin. Struct. Biol.* **2022**, 72, 237-247.

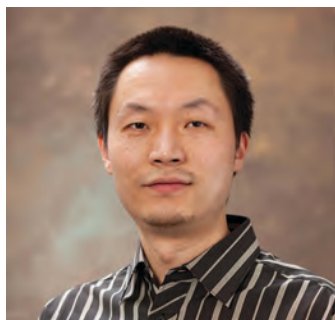
*Structural cavities are critical to balancing stability and function of a membrane-integral enzyme*, Guo, R., Cang, Z., Yao, J., Kim, M., Deans, E., Wei, G., Kang, S.-g., and Hong, H., *Proc. Natl. Acad. Sci. USA* **2020**, 117, 22146-22156.

*The rhomboid protease GlpG has weak interaction energies in its active site hydrogen bond network*, Gaffney, K. and Hong, H., *J. Gen. Physiol.* **2018**, 151, 282-291. (Highlighted in JGP research news.)

*Folding-degradation relationship of a membrane protein mediated by the universally conserved ATP-dependent protease FtsH*, Yang, Y., Guo, R., Gaffney, K., Kim, M., Muhammednazaar, S., Wang, B., Wei, T., Liang, J., and Hong, H., *J. Am. Chem. Soc.* **2018**, 140, 13, 4656-4665. (Selected as a JACS spotlight article.)

*Steric trapping reveals a cooperative network in the intramembrane protease GlpG*, Guo, R., Gaffney, K.A., Kim, M., Yang, Z., Sungsoowan, S., Huang, X., Hubbell, W.L. and Hong, H., *Nature Chem. Biol.* **2016**, 12, 353-360.

*Toward understanding driving forces in membrane protein folding*, Hong, H., *Arch. Biochem. Biophys.* **2014**, 564, 297-313.



**Jian Hu**

## Membrane Protein Structure-Function Characterization

### ASSOCIATE PROFESSOR

B.S.,  
Peking Univ.;  
Ph.D.,  
Peking Univ.;  
Postdoctoral Research Assoc.,  
Florida State Univ. and National High  
Magnetic Field Laboratory;  
Postdoctoral Research Assoc.,  
Yale Univ.;  
Associate Research Scientist,  
Yale Univ.



517-353-8680

### SELECTED PUBLICATIONS

*Zinc transporter mutations linked to Acrodermatitis enteropathica disrupt function and cause mistrafficking*, Kuliye, E., Zhang, C., Sui, D., and Hu, J., *J. Biol. Chem.* **2021** (in press).

*Toward unzipping the ZIP metal transporters: structure, evolution, and implications on drug discovery against cancer*, Hu, J., *FEBS J.* **2021** (in press; **invited State-of-the-Art Review**).

*Molecular basis of zinc-dependent endocytosis of human ZIP4 transceptor*, Zhang, C., Sui, D., Zhang, T. and Hu, J., *Cell Rep.* **2020**, *31*(4), 107582. PMID: 32348750.

*Asymmetric functions of a binuclear metal center within the transport pathway of a human zinc transporter ZIP4*, Zhang, T., Sui, D., Zhang, C., Cole, L. and Hu, J., *The FASEB J.* **2020**, *34*(1), 237-247. PMID: 31914589

*Structural insights into lethal contractural syndrome type 3 (LCCS3) caused by a missense mutation of PIP5K $\gamma$* , Zeng, X., Uyar, A., Sui, D., Donyapour, N., Wu, D., Dickson, A., and Hu, J. *J.Biochem J.* **2018**, *475*(14), 2257-2269.

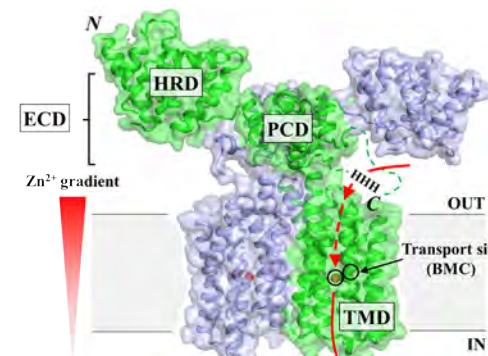
*Crystal structures of a ZIP zinc transporter reveal a binuclear metal center in the transport pathway*, Zhang, T., Liu, J., Fellner, M., Zhang, C., Sui, D. and Hu, J., *Sci. Adv.* **2017**, *3*(8), e1700344.

*Structural insights into the catalytic mechanism of LarE, a sacrificial sulfur insertase of the N-type ATP pyrophosphatase family*, Fellner, M., Desguina, B., Hausinger, R.P., and Hu, J. *Proc. Natl. Acad. Sci. USA* **2017**, *114*(34): 9074-9079.

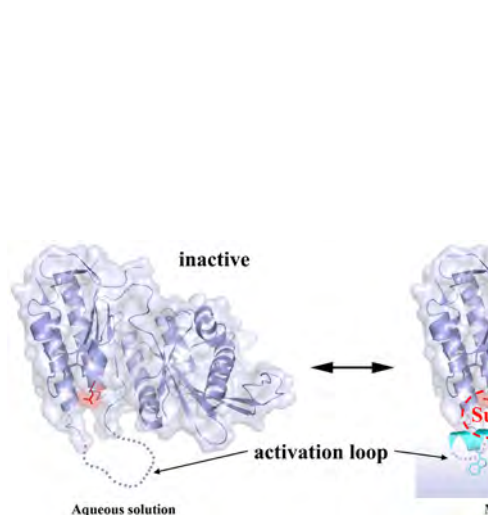
*Structures and mechanisms of the non-heme Fe(II)- and 2-oxoglutarate-dependent ethylene-forming enzyme: substrate binding creates a twist*, Martinez, S., Fellner, M., Herr, C.Q., Ritchie, A., Hu, J.<sup>†</sup>, and Hausinger, R.P., *JACS* **2017**, *139*(34): 11980-11988.

The Hu lab has broad interest in structural biochemistry of macromolecules important in biology and biomedicine with a focus on bio-metal utilization and homeostasis. By deploying multidisciplinary approaches, including those in structural biology (x-ray crystallography, cryo-EM, and NMR), biochemistry, biophysics, and cell biology, we aim to clarify the working mechanisms of macromolecules at atomic resolution. Three major ongoing projects are outlined below.

**ZIP metal transporters** - The Zrt-/Irt-like protein (ZIP) family members are ubiquitously expressed in nearly all the living organisms and play a central role in homeostasis of life-essential d-block metals (primarily Zn, Fe, and Mn). We strive to clarify the structural basis of (1) the alternating access transport mechanism, (2) substrate specificity and promiscuity, and (3) substrate-dependent endocytosis of eukaryotic ZIPs. Rationally engineering plant ZIPs to reduce heavy metal (particularly Cd) contamination in food is another ongoing project. Seeking ZIP-specific inhibitors/antibodies as cancer therapeutics is also under investigation (Figure 1).

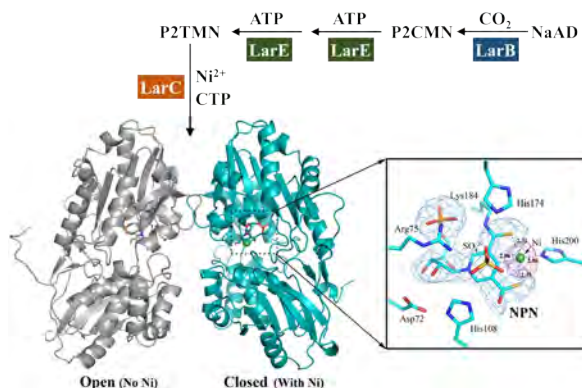


**Figure 1. Overview of the ZIP project.**



**Figure 3. Activation loop (cyan) acts as a membrane sensor governing the activity of PIPKs.**

**Lar proteins** - LarA from *Lactobacillus plantarum* (LarA<sub>LP</sub>) is the founding member of the LarA racemase/epimerase family. The activity of LarA<sub>LP</sub> relies on a newly-discovered Ni-pincer nucleotide (NPN) cofactor which is biosynthesized by three novel enzymes LarB, LarC and LarE in the lar operon. We have been collaborating with Dr. Robert P. Hausinger in MMG to (1) establish the structural basis of catalysis conducted by LarA<sub>LP</sub> and LarA homologs broadly distributed in prokaryotes, and (2) clarify the process and the underlying mechanism of biosynthesis of the NPN cofactor (Figure 2).



**Figure 2. Biosynthesis of the NPN cofactor (upper) and the crystal structure of LarA<sub>LP</sub> (lower).**

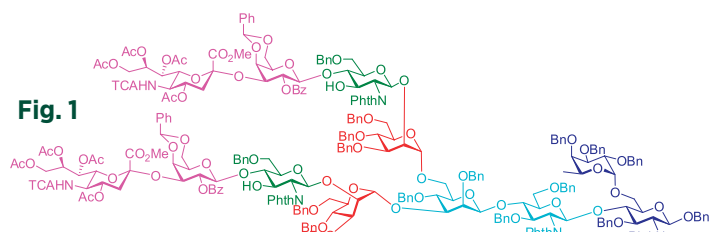


**PIPK lipid kinases** - Phosphatidylinositol phosphate kinase (PIPK) family members produce the three types of PIP<sub>2</sub>, all of which are crucial signaling molecules involved in numerous biological processes. PIPKs are also potential drug targets for human diseases, including cancers, diabetes, inflammations,

chronic pain, as well as viral infection (COVID-19 in particular). We aim to delineate the membrane sensing mechanism and the molecular basis of substrate promiscuity. We are also targeting the substrate binding site to develop non-ATP competitive inhibitors through collaboration with Dr. Xuefei Huang in Chemistry (Figure 3). ♡

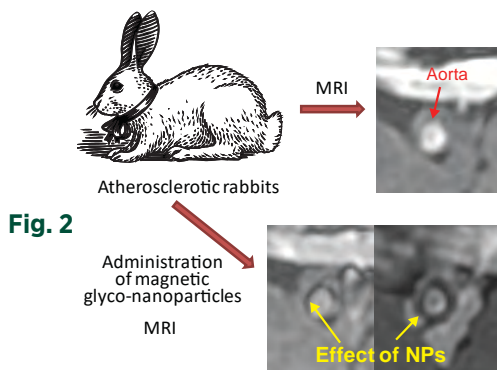
The chemistry of carbohydrates and their biology is the major emphasis of our research. Carbohydrates play important roles in many biological processes such as inflammation, tumor metastasis, bacterial and viral infections. Detailed understanding of many of these processes is still lacking. Building on our strength in synthetic chemistry, we take a multi-disciplinary approach to study this important class of molecules. Our research encompasses several areas including **synthetic organic chemistry**, **nanoscience** and **chemical immunology**.

In the **synthetic chemistry** area, we are developing novel methodologies for assembling biologically active oligosaccharides and glycoconjugates. Traditional carbohydrate synthesis is very tedious and time-consuming. In order to expedite the synthetic process, we have developed novel one-pot glycosylation methodologies, where multiple sequential glycosylation reactions are carried out in a single reaction flask to yield desired oligosaccharides without time-consuming intermediate purifications. One of the methods we developed, the pre-activation based iterative one-pot method, has achieved higher synthetic efficiencies in several syntheses compared to the automated solid phase based method. We are applying the methods we developed to total synthesis of a wide range of highly complex oligosaccharides and glycoconjugates. A representative example of the molecules we have synthesized is shown in **Fig. 1**. We are continuing to synthesize biologically important carbohydrates.



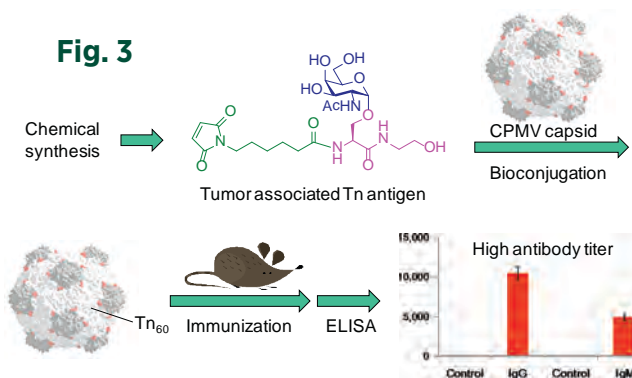
In our **nanoscience** program, we combine the multifaceted properties of carbohydrates with the unique functions of nanoparticles by immobilizing carbohydrates onto the external surface of magnetic nanoparticles. The magnetic glyco-nanoparticles (MGNPs) produced retain the biological recognition of carbohydrates and at the same time enhance the avidity of carbohydrate-receptor interactions by thousands of times. The magnetic nature of the nanoparticles enables us to use magnetic resonance imaging (MRI) as a non-invasive method for disease detection. An example of this is shown in **Fig. 2**, where the presence of atherosclerotic plaques (the major cause of heart attack and stroke) in

rabbits can be easily detected by MRI after injection of the MGNPs. Besides detection and imaging applications, we are exploring the utility of MGNPs for targeted drug delivery. We found that by incorporating drugs onto MGNPs, the cytotoxicity of the drugs towards cancer cells can be significantly enhanced. We are continuing to develop magnetic glyco-nanoparticles for non-invasive detection and treatment of diseases such as cancer, atherosclerosis and Alzheimer's disease.



In the **immunology** area, harnessing the awesome power of body's immune system to fight cancer is an attractive strategy to cancer treatment. It is well known that many tumor cells have unique carbohydrate structures over-expressed on the cell surface. However, the low immunogenicities of these tumor associated carbohydrate antigens present a formidable challenge for the development of carbohydrate based anti-cancer vaccines. To overcome this obstacle, we are developing novel carrier systems such as cowpea mosaic virus capsid (CPMV) and bacteriophage Q $\beta$  to deliver tumor associated carbohydrate antigens to the immune system and to boost the immune responses against carbohydrates as diagrammed in **Fig. 3**. We discovered that antigens displayed in a highly organized manner can elicit

much stronger immune responses. Vaccination with our constructs successfully protected the immunized mice from tumor development in several tumor models. This is an excitingly new direction for the development of anti-cancer vaccines. 🍀



**Xuefei Huang**

**Organic Chemistry,  
Synthetic Chemistry,  
Nanoscience and  
Immunology**

**MSU FOUNDATION PROFESSOR  
AND  
PROFESSOR OF  
BIOMEDICAL ENGINEERING**

B.S.,  
Univ. of Science and Technology of China;  
M.A., M.Phil.,  
Columbia Univ.;  
Ph.D.,  
Columbia Univ.;  
Assistant Professor,  
Univ. of Toledo;  
Associate Professor,  
Univ. of Toledo;  
Associate Professor,  
Michigan State Univ.;  
Professor,  
Michigan State Univ.



517-353-1076

**SELECTED PUBLICATIONS**

*Chemical Synthesis and Immunological Evaluation of Pertussis-Like Pentasaccharide Bearing Multiple Rare Sugars as a Potential Anti-pertussis Vaccine*, Wang, P.; Huo, C.-X.; Lang, S.; Caution, K.; Nick, S. T.; Dubej, P.; Deora, R.; Huang, X., *Angew. Chem. Int. Ed.* **2020**, *59*, 6451-6458. *Highlighted in Synfacts 2020*, *16*, 0471.

*Glyco-engineering of Natural Killer Cells with CD22 Ligands for Enhanced Anti-cancer Immunotherapy*, Wang, X.; Lang, S.; Tian, Y.; Zhang, J.; Yan, X.; Fang, Z.; Weng, J.; Lu, N.; Wu, X.; Li, T.; Cao, H.; Li, Z.; Huang, X., *ACS Cent. Sci.* **2020**, *6*, 382-389.

*Long Range Stereodirecting Participation across a Glycosidic Linkage in Glycosylation Reactions*, Yang, W.; Zhang, J.; Yang, C.-W.; Ramadan, S.; Staples, R.; Huang, X., *Org. Lett.* **2021**, *23*, 1153-1156.

*Chemoenzymatic Synthesis of 9NHAc-GD2 Antigen to Overcome Hydrolytic Instability of O-Acetylated-GD2 for Anticancer Conjugate Vaccine Development*, Wu, X.; Ye, J.; Kavunja, H.; Delaitch, A.; Rashidjahanabad, Z.; Lang, S.; Kakeshpour, T.; Zhao, Y.; Ramadan, S.; Vilar Saavedra, P.; Yuzbasiyan-Gurkan, V.; Cao, H.; Gildersleeve, J. C.; Huang, X., *Angew. Chem. Int. Ed.* **2021**, *60*, 24179-24188.

*Virus like particle display of Vibrio cholerae O-specific polysaccharide as a potential vaccine against cholera*, Rashidjahanabad, Z.; Kelly, M.; Kamruzzaman, M.; Qadri, F.; Bhuiyan, T. R.; McFall-Boegeman, H.; Wu, D.; Piszczek, G.; Xu, P.; Ryan, E. T.; Huang, X., *ACS Infect. Dis.* **2022**, *8*, 574-583.



**James E. (Ned) Jackson**

## Mechanism and Design in Green and Organic Materials Chemistry

### PROFESSOR

A.B.,  
Harvard Univ.;  
Ph.D.,  
Princeton Univ.;  
Postdoctoral Fellow,  
Ohio State Univ.

517-353-0504



### SELECTED PUBLICATIONS

- Dihydrogen Bonding: Structures, Energetics, and Dynamics*, Custelcean, R.; Jackson, J. E., *Chem. Rev.* **2001**, *101*, 1963-1980.
- (Anti)aromaticity-Modulated Hydrogen Bonding*, Kakeshpour, T.; Wu, J. I.; Jackson, J. E., *J. Am. Chem. Soc.* **2016**, *138*, 3427-3432.
- High-Field NMR Spectroscopy Reveals Aromaticity-Modulated Hydrogen Bonding (AMHB) in Heterocycles*, Kakeshpour, T.; Bailey, J. P.; Jenner, M. R.; Howell, D. E.; Staples, R. J.; Holmes, D.; Wu, J. I.; Jackson, J. E., *Angew. Chem. Int. Ed.* **2017**, *56*, 9843-9846.
- A New Tool To Guide Halofunctionalization Reactions: The Halenium Affinity (HalA) Scale*, Ashtekar, K. D.; Marzijarani, N. S.; Jaganathan A.; Holmes, D.; Jackson, J. E.; Borhan, B., *J. Am. Chem. Soc.* **2014**, *136*, 13355-13362.
- Mechanisms and time-resolved dynamics for trihydrogen cation (H<sup>+</sup>) formation from organic molecules in strong laser fields*, Ekanayake, N.; Nairat, M.; Kaderiya, B.; Feizollah, P.; Jochim, B.; Severt, T.; Berry, B.; Kanaka, R. P.; Carnes, K. D.; Pathak, S.; Rolles, D.; Rudenko, A.; Ben-Izhak, I.; Mancuso, C. A.; Fales, B. S.; Jackson, J. E.; Levine, B. G.; Dantus, M., *Sci. Rep.* **2017**, *7*, Art. 4703.
- Absolute and relative facial selectivities in organocatalytic asymmetric chlorocyclization reactions*, Salehi Marzijarani, N.; Yousefi, R.; Jaganathan, A.; Ashtekar, K.; Jackson, J. E.; Borhan, B., *Chem. Sci.* **2018**, *9*, 2898-2908.
- Electrocatalytic Upgrading of Model Lignin Monomers with Earth Abundant Metal Electrodes*, Lam, C.H.; Lowe, C.B.; Li, Z.; Longe, K.N.; Rayburn, J.T.; Caldwell, M.A.; Houdek, C.E.; Maguire, J.B.; Saffron, C.M.; Miller, D.J.; Jackson, J.E., *Green Chem.* **2015**, *17*, 601-609.
- Towards sustainable hydrocarbon fuels with biomass fast pyrolysis oil and electrocatalytic upgrading*, Lam, C. H.; Das, S.; Erickson, N. C.; Hyzer, C. D.; Garedeew, M.; Anderson, J. E.; Wallington, T. J.; Tamor, M. A.; Jackson, J. E.; Saffron, C. M., *Sustainable Energy Fuels* **2017**, *1*, 258-266 (cover article).
- Stereoretentive H/D exchange via an electroactivated heterogeneous catalyst at sp<sup>3</sup> C-H sites bearing amines or alcohol*, Bhatia, S.; Spahlinger, G.; Bukhuseen, N. Boll, Q.; Li, Z.; Jackson, J. E., *Eur. J. Org. Chem.* **2016**, 4230-4235.
- Structural and morphological evaluation of Ru-Pd bimetallic nanocrystals*, Ma, X.; Lin, R.; Ofofi, R. Y.; Mei, Z.; Jackson, J. E., *Mater. Chem. Phys.* **2016**, *173*, 1-6.

<https://icer.msu.edu/about/announcements/icer-student-highlights-aseel-bala>

<https://icer.msu.edu/about/announcements/icer-student-highlights-Tayeb-Kakeshpour>

Probing mechanisms and theory, from molecular interactions to process design, Jackson group efforts range from fundamental...

- Hydrogen bond insights, including hydridic-to-protonic and aromaticity-modulated systems<sup>1-3</sup>
- Computational modeling to design and interpret reaction mechanisms and structures<sup>4-6</sup>

...to eminently practical chemistry:

- “Green” catalysts and pathways from renewables to useful “petro-” chemicals<sup>7-10</sup>
- Studies of bio-relevant solvents to connect molecular interactions to engineering properties.<sup>11</sup>

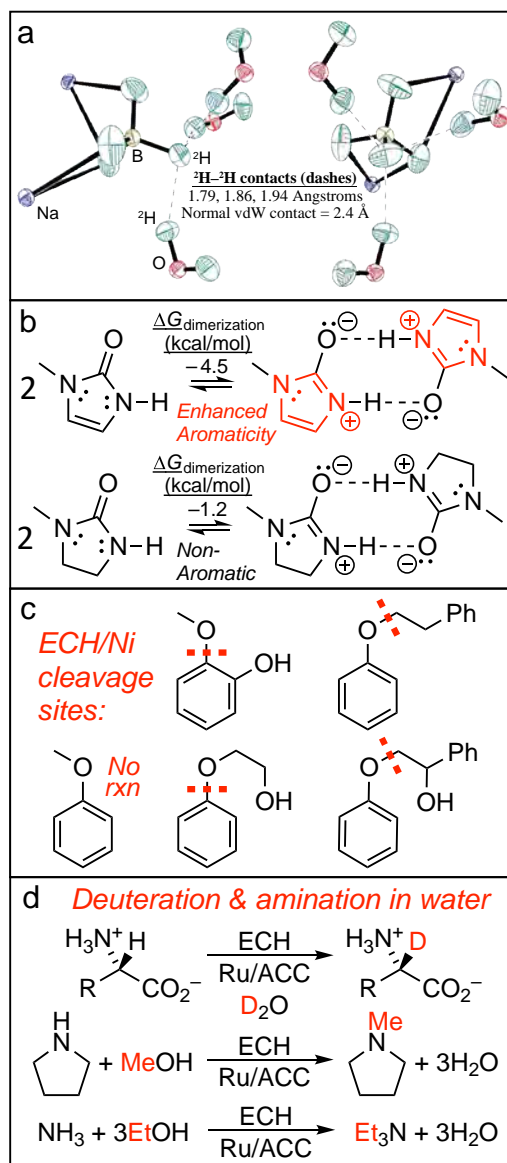
More information can be found at [www2.chemistry.msu.edu/faculty/jackson/](http://www2.chemistry.msu.edu/faculty/jackson/); two active areas are outlined below, where the common thread is mechanistic. By understanding molecular interactions and reactions we seek rules to design materials and processes with targeted characteristics. From the post-doc to the high-school level, scientists trained in the group have gone on to excellent positions in academics, industry, or governmental research.

**Novel Hydrogen Bonds** - Our discovery and studies of hydridic-to-protonic H-bonding, AKA dihydrogen bonding, began with a HS student studying NaBH<sub>4</sub>•2H<sub>2</sub>O (Fig. 1a) and includes crystal engineering, searches for bio- and synthesis relevance, and infrared-activated bond-selective reactions.<sup>1</sup> We have also uncovered aromaticity/antiaromaticity-modulation of common H-bond strengths (AMHB, Fig. 1b) and have begun collaborative studies with chemical engineers to use our molecular-level understanding of H-bonding to develop practical models for properties and separations of alcohols and other bio-relevant liquids.<sup>2-3</sup>

**Green Chemistry** - We seek to replace fossil petroleum with renewables to make chemicals and fuels via catalytic paths starting from biomass feedstocks.<sup>7-9</sup> Finite renewable carbon supplies call for C-retentive upgrading (i.e. reduction) of low-value lignin with energy from non-fossil sources. All these (wind, solar, hydro, nuclear) make electric power, so upgrading via electrocatalytic hydrogenation (ECH) is a focus, and has also turned up some novel ether cleavage and C-H activations (Fig. 1c). Having also uncovered very mild electrocatalytic C-H activation chemistry at HOC-H and R<sub>2</sub>NC-H sites in various molecules, we have now demonstrated that this activation process can be harnessed to use alcohols to alkylate amines, forming water

as byproduct (Fig. 1d). Meanwhile, mechanistic studies aid in design/optimization of catalysts and conditions.<sup>7-10</sup>

**Synergy** - Our catalytic and electrocatalytic reductions of bio-derived feedstocks in water (practical) and our C-H activation/amination chemistry now intersect with the dihydrogen bond (fundamental) work; interfacial dihydrogen bonding of metal-bound hydride sites under water may tune their reactivity. In turn, our AMHB studies (fundamental) are helping to inform the engineering solvent work (practical).<sup>11</sup> Such synergies between practical and fundamental; synthesis, structure and mechanism; and experiment and theory pull us back to the lab each day. ☺



**Figure 1.** (a) Structure of NaBD<sub>4</sub>•2D<sub>2</sub>O showing close D...D contacts of three D<sub>2</sub>O molecules to one BD<sub>4</sub><sup>-</sup> deuteron; (b) Aromaticity-enhanced H-bonds vs. localized reference; (c) Surprisingly diverse ether bond cleavages promoted by mild (60 °C, aqueous electrolyte, skeletal Ni cathode) electrocatalytic reduction; (d) Mild aqueous electrocatalytic C-H activation and halide-free amination using simple alcohols.

Research in our laboratory aims to understand the molecular underpinnings of biological systems and pathways at multiple levels. We take a multidisciplinary approach combining structural biology (x-ray crystallography, electron microscopy), biochemistry, biophysics (analytical ultracentrifugation, isothermal titration calorimetry, surface plasmon resonance, etc.), chemical biology, cell biology, and computational methods to investigate the mechanisms that underlie fundamental biological processes at atomic, molecular, cellular, and systems levels. Our current research efforts are mainly directed towards the following areas:

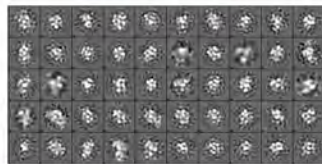
### Molecular basis of cell-cell communication in development

Formation of multicellular structures with specific biological functions, such as tissues that manifest planar polarity, entails intricate communication networks whereby cells 'talk' to each other through specific molecular interactions to coordinate their activities and collectively form elaborate multicellular structures. Planar polarity is a property required for diverse developmental processes that polarizes orientation and behavior of cells across a tissue plane. Defects in planar polarity are associated with a variety of diseases, including cancer, polycystic kidney disease, and neural tube defects. The core components of planar polarity signaling include Celsr adhesion GPCRs, which establish polarized cell-cell junctions across proximal-distal cell boundaries by recruiting distinct molecular complexes to the membrane. Ongoing work in our laboratory aims at gaining structural insights into activation mechanisms of the Celsr adhesion GPCRs with respect to their ectodomain interactions, propagation of conformational changes in the receptor domains across the membrane, and interaction of the receptors with their downstream effectors.

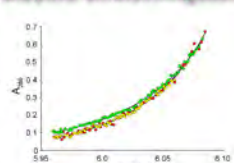
x-ray crystallography



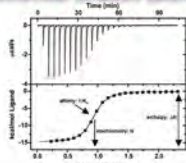
electron microscopy



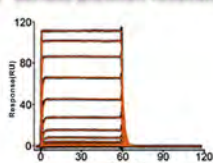
analytical ultracentrifugation



isothermal titration calorimetry



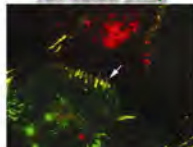
surface plasmon resonance



liposome-based assay



cell-based assay



### Structural basis for molecular interactions regulating autophagy

Autophagy is an evolutionarily conserved process through which cells degrade and recycle unnecessary components to produce new molecular building blocks. As such, it is essential for cellular and tissue homeostasis as well as cell adaptation or survival under stress conditions. Dysregulation of autophagy is implicated in many pathological situations such as cancer, diabetes, and neurodegenerative diseases. The long-term goal of this line of research is to gain an in-depth understanding of the specific molecular interactions that drive distinct steps in the process of autophagy. Our current efforts focus on the autophagy factors essential for autophagosome biogenesis and autophagosome-vacuole fusion processes in fission yeast, which will allow us to tease apart species-specific as well as evolutionarily conserved molecular interaction principles that govern autophagy.

### Structural basis for molecular interactions regulating necrotic cell death

Cell death is a crucial process during development, homeostasis, and (patho)physiology of multicellular organisms. An imbalance in cell death is linked to many diseases; too much or too sensitive cell death is associated with inflammatory and degenerative diseases, whereas too little or too insensitive cell death can promote cancer and autoimmune diseases. Necrotic cell death is morphologically characterized by cytoplasmic granulation and organelle swelling followed by the loss of cell membrane integrity and release of the cellular contents into the surrounding extracellular space. During regulated necrosis, stimulation of death receptors induces formation of a supramolecular signaling complex termed necrosome, which translocates from cytosol to the plasma and intracellular membranes and forms membrane disrupting pores, thereby executing cell death.

Ongoing work in our laboratory aims at elucidating the structural basis for the molecular interactions that underlie membrane disruption in necrosis. By combining biochemical and structural approaches, we seek to characterize the protein-protein and protein-lipid interactions required for necrotic membrane disruption; obtain structural models for the membrane disruptive molecular machineries; and validate our models using quantitative liposome- and cell-based functional assays. 🌟



Xiangshu Jin

## Biological and Physical Chemistry, Structural Biology

### ASSISTANT PROFESSOR

B.S.,  
Peking Univ., China;

Ph.D.,  
Michigan State Univ.;

Postdoctoral Research Associate,  
Michigan State Univ.;

Postdoctoral Research Fellow,  
Harvard Univ.;

Associate Research Scientist,  
Columbia Univ.;

Assistant Investigator,  
National Institute of Biological Sciences,  
Beijing, China.



517-353-9334

### SELECTED PUBLICATIONS

*Gating of the TrkH ion channel by its associated RCK protein*, TrkA, Cao, Y.; Pan, Y.; Huang, H.; Jin, X.; Levin, E.J.; Kloss, B.; Zhou, M., *Nature* **2013**, 496(7445), 317-322.

*Crystal structures of Drosophila N-cadherin ectodomain regions reveal a widely used class of Ca<sup>2+</sup>-free interdomain linkers*, Jin, X.; Walker, M.A.; Felsővalyi, K.; Vendome, J.; Bahna, F.; Manneppalli, S.; Cosmanescu, F.; Ahlsen, G.; Honig, B.; Shapiro, L., *Proc. Natl. Acad. Sci. U.S.A.* **2012**, 109(3), E127-134.

*Crystal structure of a phosphorylation-coupled saccharide transporter*, Cao, Y.; Jin, X.; Levin, E.J.; Huang, H.; Zong, Y.; Quick, M.; Weng, J.; Pan, Y.; Love, J.; Punta, M.; Rost, B.; Hendrickson, W.A.; Javitch, J.A.; Zhou, M., *Nature* **2011**, 473(7345), 50-54.

*Crystal structure of a potassium ion transporter TrkH*, Cao, Y.; Jin, X.; Huang, H.; Derebe, M.G.; Levin, E.J.; Kabaleeswaran, V.; Pan, Y.; Punta, M.; Love, J.; Weng, J.; Quick, M.; Ye, S.; Kloss, B.; Bruni, R.; Martinez-Hackert, E.; Hendrickson, W.A.; Rost, B.; Javitch, J.A.; Rajashankar, K.R.; Jiang, Y.; Zhou, M., *Nature* **2011**, 471(7338), 336-340.

*Splice form dependence of beta-neurexin/neuroigin binding interactions*, Koehnke, J.; Katsamba, P.S.; Ahlsen, G.; Bahna, F.; Vendome, J.; Honig, B.; Shapiro, L.; Jin, X., *Neuron* **2010**, 67(1), 61-74.

*Crystal structure of the extracellular cholinesterase-like domain from neuroigin-2*, Koehnke, J.; Jin, X.; Budreck, E.C.; Posy, S.; Scheiffele, P.; Honig, B.; Shapiro, L., *Proc. Natl. Acad. Sci. U.S.A.* **2008**, 105(6), 1873-1878.

*The ankyrin repeats of TRPV1 bind multiple ligands and modulate channel sensitivity*, Lishko, P.V.; Procko, E.; Jin, X.; Phelps, C.B.; Gaudet, R., *Neuron* **2007**, 54(6), 905-918.

*Crystal structure of potato tuber ADP-glucose pyrophosphorylase*, Jin, X.; Ballicora, M.A.; Preiss, J.; Geiger, J.H., *EMBO Journal* **2005**, 24(4), 694-704.



**Seokyoung Kim**

**Nanomaterials  
Synthesis,  
Photonics and  
Solar Energy**

**ASSISTANT PROFESSOR**

B.S.,  
Pohang Univ. of Science and Technology  
(POSTECH) South Korea;  
M.S.,  
Univ. of Massachusetts at Amherst  
Ph.D.,  
Univ. of North Carolina at Chapel Hill;  
IIN Postdoctoral Fellow,  
Northwestern Univ.;

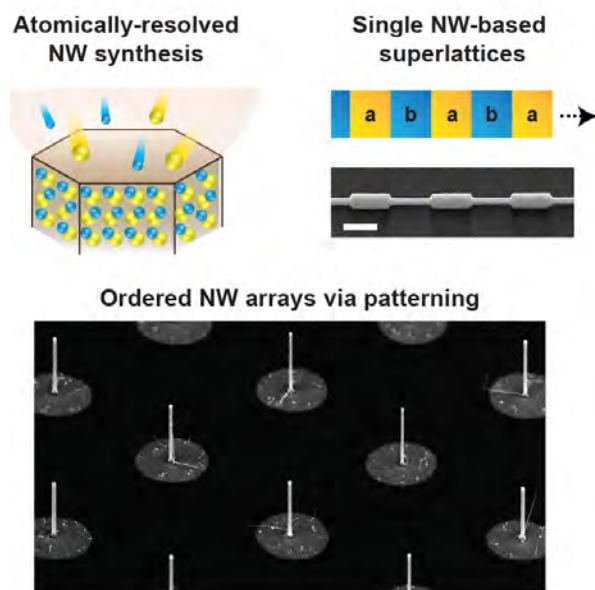
517-353-1205



One-dimensional (1D) semiconductor nanowires (NWs) present a cylindrical cross-section confined to the nanoscale (<10 to ~1000 nm) with an axial dimension extended to a much larger length scale (~100 nm to ~1 mm). This distinct NW geometry gives rise to a variety of unique quantum-electronic, nano-optical, and transport properties, and in the past decades, NWs have emerged as an ideal platform for creating ultra-small nano-devices for technologies including nanoelectronics, photonics, and solar energy conversion by virtue of the excellent crystal quality, precise doping control, and wide access to various materials.

The Kim group is interested in synthesizing semiconductor NWs through vapor-liquid-solid (VLS) growth with various materials compositions, doping profiles, and geometric

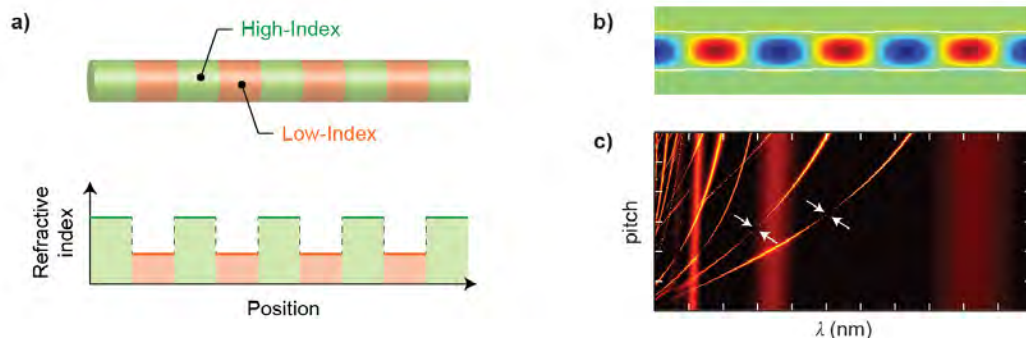
be equipped with precise gas regulation apparatus capable of flowing gas-phase precursors of various materials at a wide range of pressure and temperature. Optimized growth is expected to produce NWs with clean surfaces, uniform diameters and a true nanoscale spatial resolution at the near-atomic level (Top-left, Figure 1). Moreover, a rapid switching of precursors and/or dopants creates abrupt heterojunctions within individual NWs, which, when repeated, can produce periodically modulated NW superlattices (Top-right, Figure 1). We also combine epitaxial, vertical growth of these NWs with lithographic patterning to prepare large-area ordered arrays (Bottom, Figure 1). These 2D NW arrays find a number of applications as tunable photonic lattices, metasurfaces, NW solar cells, and photonic topological insulators.



**Figure 1. VLS growth of NWs, design of NW superlattices, and image of ordered NW arrays.**

Another primary research area of the Kim group is to study novel photonic/meta-optical properties of NW superlattices using finite-element numerical modeling and precision spectroscopy. Figure 2a shows a simple example of the design of an index-modulated NW superlattice that can exhibit photonic guided resonances as shown in Figure 2b. Precisely tailored NW superlattices present unique photonic properties that no other single nanostructures can easily possess such as optical bound states in the continuum (BICs, Figure 2c). These optical resonances and states are the unique ways of confining light waves inside the NWs with quality factors (or photon lifetimes) much higher than what has been observed with nanostructures, which enables highly enhanced performances in photocurrent generation, luminescence, and nonlinear processes. We use numerical modeling to find the design parameters for the NW synthesis, fabricate NW devices using our MOCVD, and experimentally demonstrate the predicted properties through spectroscopy.

shapes, as well as investigating their fundamental electronic and nanophotonic properties. We are currently developing our innovative metal-organic chemical vapor deposition (MOCVD) system that will



**Figure 2. (a) Design of an index-modulated NW superlattice, (b) mode pattern of a guided resonance, and (c) a confined-energy heatmap showing optical BICs.**

**SELECTED PUBLICATIONS**

*Mie-Resonant Three-Dimensional Metacrystals*, S. Kim *et al.*, *Nano Letters* **2020**, 20(11), 8096–8101.

*Geometric Nanophotonics: Light Management in Single Nanowires through Morphology*, S. Kim, J.F. Cahoon, *Accounts of Chemical Research* **2019**, 52(12), 3511–3520.

*Photonics of Sub-Wavelength Nanowire Superlattices*, S. Kim, *MRS Advances* **2019**, 4(51-52), 2759–2769.

*Optical Bound States in the Continuum with Nanowire Geometric Superlattices*, S. Kim, K.-H. Kim, J.F. Cahoon, *Physical Review Letters* **2019**, 122, 187402.

*Mie-Coupled Bound Guided States in Nanowire Geometric Superlattices*, S. Kim *et al.*, *Nature Communications* **2018**, 9, 2781.

*Self-Catalyzed Vapor-Liquid-Solid Growth of Lead Halide Nanowires and Conversion to Hybrid Perovskites*, J.K. Meyers, S. Kim *et al.*, *Nano Letters* **2017**, 17(12), 7561–7568.

*Designing Morphology in Epitaxial Silicon Nanowires: The Role of Gold, Surface Chemistry, and Phosphorus Doping*, S. Kim *et al.*, *ACS Nano* **2017**, 11(5), 4453–4462.



My research program focuses on investigating the effect of the interaction between dietary fatty acids and environmental toxicants on human health using chemical biology methods and state-of-the-art instrumentations. More specifically, we are interested in studying the molecular mechanism on how dietary omega-3 and omega-6 polyunsaturated fatty acids (PUFAs) affects human diseases. The metabolites from omega-3 and omega-6 PUFAs are important lipid signaling molecules that play an important role in inflammation, blood pressure regulation, wound healing, cancer, pain, etc. Therefore, understanding the signaling mechanism of these potent lipid metabolites will lead to alternate treatments for diseases. Currently, we are focused on two different directions to elucidate the mechanism on how omega-3 and omega-6 PUFA metabolites affect human physiology:

**1) Identification of the receptors of polyunsaturated fatty acid (PUFA) epoxides** – PUFA epoxides are potent lipid mediators with anti-inflammatory, anti-hypertensive, anti-fibrotic and analgesic properties. They also play a vital role in cancer biology. However, even after two decades of research, the signaling mechanism of PUFA epoxides remain largely unknown. To tackle this challenge, we will design analogs of PUFA epoxides. Currently, we have identified several active analogs which allows us to pursue the identification of highly specific and high affinity epoxyeicosatrienoic acid receptor(s).

**2) Design and synthesis of analogs of omega-3 PUFA epoxide and inhibitor of soluble epoxide hydrolase with improved druglikeness to treat diseases** – Omega-3 PUFA epoxides are transient endogenous metabolites which are metabolically unstable and rapidly degraded by an enzyme called soluble epoxide hydrolase. In addition, these fatty acid epoxide are very lipophilic with poor physical properties. Therefore, they are poor drug candidates. Recently, our laboratory have employed a high-throughput screening in order to study the structure-activity-relationship of the omega-3 PUFA epoxides on fibrosis. By understanding the SAR of PUFA epoxides on fibrosis, we will be able to design analogs with better drug-like properties.

Because the soluble epoxide hydrolase (sEH) is the major metabolic enzyme for PUFA epoxides, inhibition of sEH is beneficial to human health through stabilization of PUFA epoxides *in vivo*. Thus, sEH becomes a prominent therapeutic target. Recently, it has been shown that sEH inhibitors are efficacious on diabetic neuropathic pain model in mice. Unfortunately, the properties of the current sEH inhibitors are not fully optimized. Therefore, we will redesign the structure of the sEH inhibitors to improve their drug-like properties particularly, the drug-target residence time because the drug-target residence time has been demonstrated to be an important drug parameter to predict *in vivo* efficacy of the drug. 🍀



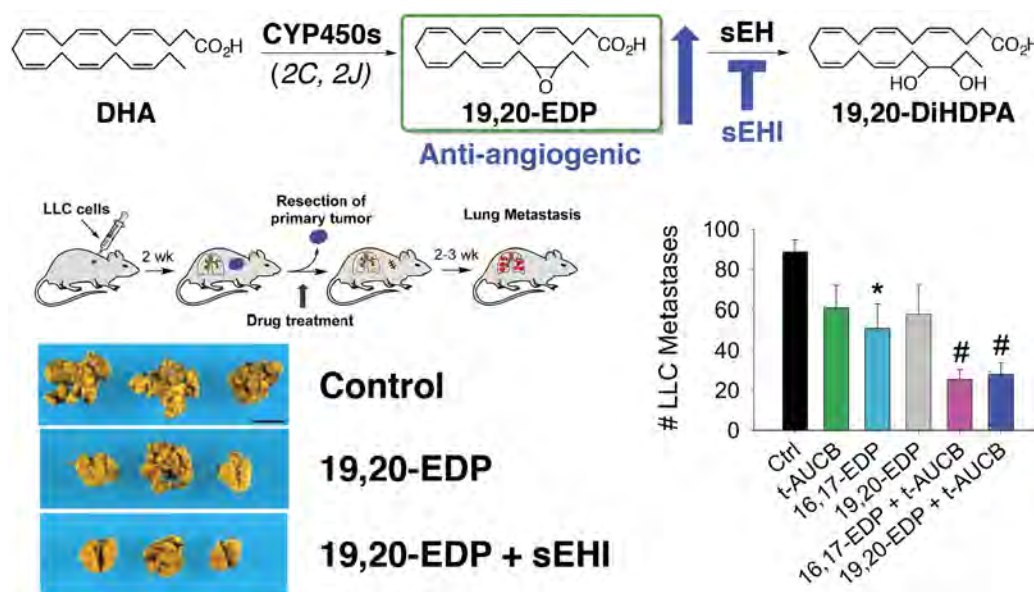
**Kin Sing Stephen Lee**

**Molecular Mechanism of Dietary Lipids and Environmental Toxicants on Human Health**

**ASSISTANT PROFESSOR AND ASSISTANT PROFESSOR OF PHARMACOLOGY AND TOXICOLOGY**  
 B.S.,  
 Hong Kong Univ. of Science and Technology;  
 Ph.D.,  
 Michigan State Univ.;  
 Post-Doctoral Scholar,  
 Univ. of California at Davis;  
 Project Scientist,  
 Univ. of California at Davis.



517-884-1813



SELECTED PUBLICATIONS

*ω-3 polyunsaturated fatty acids and their cytochrome P450-derived metabolites suppress colorectal tumor development in mice.* Wang W, Yang J, Nimiya Y, Lee KSS, Sanidad K, Qi W, Sukamtoh E, Park Y, Liu Z, Zhang G. J., *Nutr. Biochem.* **2017**, 48, 29.

*Cyclooxygenase-derived proangiogenic metabolites of epoxyeicosatrienoic acids.* Rand AA, Barnych B, Morisseau C, Cajka T, Lee KSS, Panigraphy D, Hammock BD, *Proc. Natl. Acad. Sci. U.S.A.* **2017**, 114, 4370.

*Probing the orientation of inhibitor and epoxy-eicosatrienoic acid binding in the active site of soluble epoxide hydrolase.* Lee KS, Henriksen NM, Ng CJ, Yang J, Jia W, Morisseau C, Andaya A, Gilson MK, Hammock BD, *Arch. Biochem. Biophys.* **2017**, 613, 1.

*Soluble epoxide hydrolase inhibition and epoxyeicosatrienoic acid treatment improve vascularization of engineered skin substitutes.* Supp D, Hahn J, McFarland KL, Combs KA, Lee KSS, Inceoglu B, Wan D, Boyce ST, Hammock BD, *Plast. Reconstr. Surg. Glob. Open* **2016**, 4, e1151.

*Epoxy fatty acids mediate analgesia in murine diabetic neuropathy.* Wagner K, Lee KS, Yang J, Hammock BD, *Eur. J. Pain* **2016**, 21(3), 456.



**Sean N. Liddick**

## Nuclear Chemistry

### ASSOCIATE PROFESSOR

B.S. Chemistry,  
Texas A&M Univ.;

Ph.D., Chemical Physics,  
Michigan State Univ.;

Faculty,  
National Superconducting Cyclotron  
Laboratory.

517-355-9672  
Ext. 690



### SELECTED PUBLICATIONS

*Novel techniques for constraining neutron-capture rates relevant for r-process heavy-element nucleosynthesis*, A.C. Larsen, A. Spyrou, S.N. Liddick, M. Guttormsen, *Prog. Part. Nucl. Phys.* **2019**, 107, 69. <https://doi.org/10.1016/j.ppnp.2019.04.002>

*Benchmarking the extraction of statistical neutron capture cross sections on short-lived nuclei for applications using the  $\beta$ -Oslo method*, S.N. Liddick, A.C. Larsen, M. Guttormsen, A. Spyrou, B.P. Crider, F. Naqvi, J.E. Midtbo, F.L. Bello Garrote, D.L. Bleuel, L. Crespo Campo, A. Couture, A.C. Dombos, F. Giacoppo, A. Gorgen, K. Hadynska-Klek, T.W. Hagen, V.W. Ingeberg, B.V. Kheswa, R. Lewis, S. Mosby, G. Perdikakis, C.J. Prokop, S.J. Quinn, T. Renstrom, S.J. Rose, E. Sahin, S. Siem, G.M. Tveten, M. Wiedeking, F. Zeiser, *Phys. Rev. C* **2019**, 100, 024624. <https://doi.org/10.1103/PhysRevC.100.024624>

*Experimental neutron capture rate constraint far from stability*, S. N. Liddick, A. Spyrou, B. P. Crider, F. Naqvi, A. C. Larsen, M. Guttormsen, M. Mumpower, R. Surman, G. Perdikakis, D. L. Bleuel, A. Couture, L. Crespo Campo, A. C. Dombos, R. Lewis, S. Mosby, S. Nikas, C. J. Prokop, T. Renstrom, B. Rubio, S. Siem, and S. J. Quinn, *Phys. Rev. Lett.* **2016** 116, 242502. <http://dx.doi.org/10.1103/PhysRevLett.116.242502>

*Shape coexistence in neutron-rich nuclei*, A. Gade, S.N. Liddick, *J. Phys. (London)* **2016** G43, 024001. <http://dx.doi.org/10.1088/0954-3899/43/2/024001>

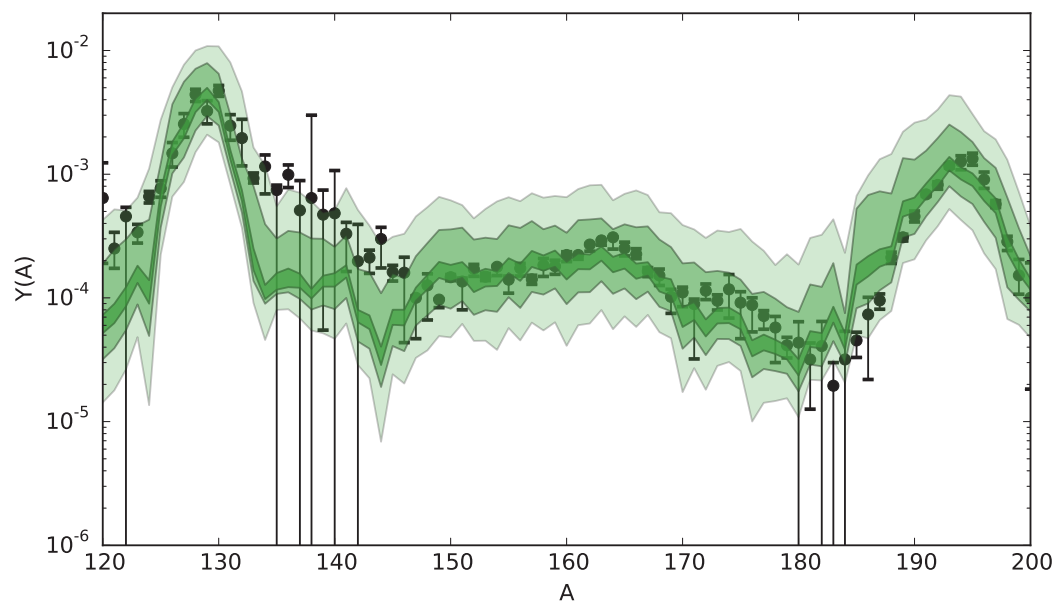
*Shape coexistence from lifetime and branching-ratio measurements in  $^{68,70}\text{Ni}$* , B.P. Crider, C.J. Prokop, S.N. Liddick, M. Al-Shudifat, A.D. Ayangekaa, M.P. Carpenter, J.J. Carroll, J. Chen, C.J. Chiara, H.M. David, A.C. Dombos, S. Go, R. Grzywacz, J. Harker, R.V.F. Janssens, N. Larson, T. Lauritsen, R. Lewis, S.J. Quinn, F. Recchia, A. Spyrou, S. Suchyta, W.B. Walters, S. Zhu, *Phys. Lett. B* **2016**, 763, 108. <http://doi.org/10.1016/j.physletb.2016.10.020>

The ease of transitions between different states of the atomic nucleus carry a wealth of information and can be used in a variety of applications from describing the basic configuration of the nucleus' constituent protons and neutrons to constraining the synthesis of heavy elements in the energetic astrophysical events. Nuclear properties are expected to vary significantly as a function of proton or neutron number as departure is made from stable nuclei. My group focuses on characterizing transition rates of ground and excited states in nuclei as a function of proton and neutron number. Radioactive nuclei are produced and isolated at the National Superconducting Cyclotron Laboratory at Michigan State University. The nuclei of interest are deposited into a solid-state detector and their subsequent decay radiations are monitored. Decay spectroscopy provides a sensitive and selective means to populate and study low-energy excited states of daughter nuclei and a variety of different decay modes can be exploited depending on the nucleus of interest.

One branch of the groups recent experimental work has focused on  $^{68}\text{Ni}_{40}$ . It has been predicted that multiple spin-zero states exist with significantly different intrinsic deformations in  $^{68}\text{Ni}$ . The energies, and decay transition rates of the excited states, can provide information on the coexisting structures. The first excited state spin-zero state of  $^{68}\text{Ni}$  decays through the emission of a conversion electron (photon emission is forbidden) which is delayed with respect to the populating beta-decay electron

resulting in a characteristic signal shape from the solid-state detector. The energy of the conversion electron provides the energy of the excited state in  $^{68}\text{Ni}$ . Combined with the decay rate of the state, the strength of the transition can be determined and compared with expectations. The results confirm the theoretical picture of both single-particle and collective configurations coexisting at similar excitation energies.

The other focus of the group lies in inferring the photon strength functions (related to the photon transition rates) of highly-excited states populated in the beta-decay of a short-lived nucleus. The photon strength function combined with a knowledge of the number of nuclear states as a function of energy enables the calculation of various reactions that are expected to occur through statistical processes. One such reaction is the capture of a neutron onto the atomic nucleus increasing its mass by one unit. Neutron capture rates are a necessary ingredient to predict elemental abundances produced in energy astrophysical events, such as supernovae and neutron star mergers, which are expected to lead to the synthesis of a significant amount of the elements heavier than iron. Abundance predictions require neutron capture rate uncertainties of roughly a factor of two while current constraints can reach over two orders of magnitude. The resulting impact on abundance predictions is shown in the figure. Recent work from my group has investigated the neutron capture of  $^{68,69}\text{Ni}$  and the resulting impact on elemental synthesis. 🌟

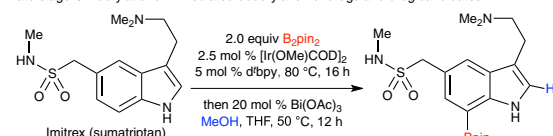


**Predicted abundances as a function of mass number compared to solar r-process residuals (black dots). The shaded bands show the variances in a large number of predicted abundance patterns taken from network calculations. In each calculation a variation of all neutron capture rates is applied. The shaded bands correspond to neutron capture rate uncertainties of a factor of 100 (light), 10 (middle), and 2 (dark). All but the largest abundance pattern features are obscured by the rate uncertainties at a factor of 100. Only with uncertainties smaller than a factor of 10 can fine features be observed.**

Our group is interested in a) green chemistry, b) the invention of new reactions and strategies in organic synthesis, and c) target synthesis of molecules with interesting properties ranging from biologically important natural products to nanomaterials.

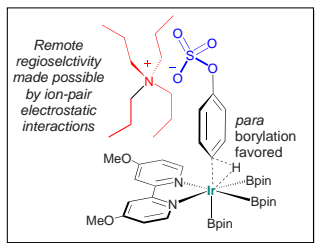
**Green Chemistry** – Central to our research is the development of efficient and environmentally benign reactions and strategies. The Pharmaceutical Roundtable of the American Chemical Society's Green Chemistry Institute deemed cross-couplings that avoid haloaromatics as their top aspirational reaction. In collaboration with Professor Mitch Smith, we are inventing such reactions. Specifically, we are using **catalytic C–H activation/borylation**, often combined with subsequent chemical events, to generate pharmaceutically relevant

Late stage CH borylation / Bi-mediated deborylation of drugs and drug candidates

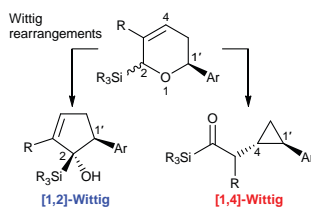


building blocks for organic synthesis and the late stage functionalization of drugs and drug candidates.

**Invention of New Reactions** – The principles of green chemistry also motivate us to create new synthetic methods. Within our catalytic borylation program, an example is our recently disclosed use of ion-pairing, where the alkyl groups of the cation create a steric shield that facilitates previously unheard of levels of para selectivity.



We are also focusing on the employment of organosilanes as both reagents and substrates in chemical transformations ranging from **Wittig rearrangements** to new approaches to double-decker silsesquioxanes (DDSQ's) for materials applications.

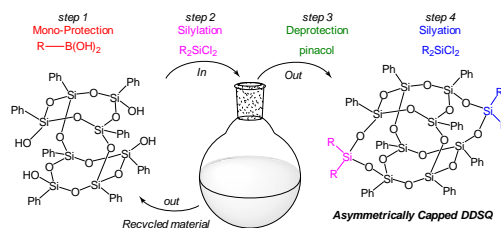


Since their discovery more than 70 years ago, Wittig rearrangements have evolved into powerful tools for the isomerization of  $\alpha$ -metalated ethers into alkoxides. Relative to the [2,3]- and [1,2]-shifts, [1,4]-Wittig rearrangements are unique in their ability to generate stereodefined enolates. In addition, [1,4]-Wittig rearrangements have

the potential to transfer chirality and stereoselectively form adjacent chiral centers. As such, we continue to study these mechanistically fascinating and synthetically intriguing rearrangements.

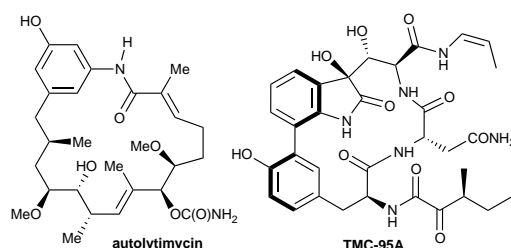
We have also teamed up with Chemical Engineering and Materials Science Professor Andre Lee, to apply our synthetic expertise to another remarkable class of compounds, namely **silsesquioxanes**. These caged structures have garnered significant attention over their ability to meet the demands of medical, aerospace and materials industries. This is due to the well-defined spatial dimensions, the presence of seven inert peripheral organic moieties to accommodate solubility and processability, and one polymerizable reactive organic group.

Like our other projects, we approach the synthesis of silsesquioxane through the lens of green chemistry. An example of this can be seen in our development of the first direct synthetic route leading to asymmetrically functionalized DDSQ compounds. By way of our route over 50% of the starting DDSQ tetraol that could have



otherwise contributed toward the synthesis of unwanted side products is recovered with a high purity and can be used in another cycle of synthesis. Efforts to use these compounds as nano-linkers to two different block copolymers are underway in our lab.

**Target Synthesis** – A unifying thesis behind all of our methodological and mechanistic studies is that the chemistry to emerge from such studies should be **applicable to real synthetic problems**. We view target synthesis as the best proof of this concept. For example, as part of our green chemistry program, we look to make TMC-95A and autolytymycin by the strategic application of our own synthetic methods. 🍀



**Robert E. Maleczka, Jr.**

## Synthetic Organic Chemistry

**PROFESSOR**

B.S.,  
Univ. of Illinois at Urbana-Champaign;  
Abbott Labs;  
Ph.D.,  
The Ohio State Univ.;  
Postdoctoral Fellow,  
American Cancer Society,  
Univ. of Pennsylvania.



517-353-0834

### SELECTED PUBLICATIONS

*Steric shielding effects induced by intramolecular C–H...O hydrogen bonding: Remote borylation directed by Bpin groups*, Montero Bastidas, J.R.; Chhabra, A.; Feng, Y.; Oleskey, T.J.; Smith, M.R., III; Maleczka, R.E., Jr., *ACS Catal.* **2022**, *12*, 2694–2705.

*Merging Iridium-Catalyzed C–H Borylations with Palladium-Catalyzed Cross-Couplings using Triorganoinidyl Reagents*, Jayasundara, C.R.K.; Gil-Negrete, J.-M.; Montero Bastidas, J.R.; Chhabra, A.; Martinez, M.M.; Sestelo, J.P.; Smith, M.R., III; Maleczka, R.E., Jr., *J. Org. Chem.* **2022**, *87*, 751–759.

*Amide Directed Iridium C(sp<sup>3</sup>)-H Borylation Catalysis with High N-Methyl Selectivity*, Dannatt, J.E.; Yadav, A.; Smith, M.R., III; Maleczka, R.E., Jr., *Tetrahedron* **2022**, *109*, 132578.

*Silylcyclopropanes by Selective [1,4]-Wittig Rearrangement of 4-Silyl-5,6-Dihydropyrans*, Mori-Quiroz, L.M.; Maloba, E.W.; Maleczka, R.E., Jr., *Org. Lett.* **2021**, *23*, 5724–5728.

*Phase behavior of selected condensed double-decker shaped silsesquioxane compounds*, Vogelsang, D.F.; Maleczka, R.E., Jr.; Lee, A., *Silicon* **2021**, *13*, published on-line 11/4/2021.

*One-Pot Iridium Catalyzed C–H Borylation/Sonogashira Cross-Coupling: Access to Borylated Aryl Alkynes*, Chotana, G. A.; Montero Bastida, J. R.; Miller, S. L.; Smith, M. R., III; Maleczka, R. E., Jr., *Molecules* **2020**, *25*, 1754–1766.

*Para-Selective, Iridium-Catalyzed C–H Borylations of Sulfated Phenols, Benzyl Alcohols, and Anilines Directed by Ion-Pair Electrostatic Interactions*, M. Bastida, J. R.; Oleskey, T. J.; Miller, S. L.; Smith, M. R., III; Maleczka, R. E., Jr., *J. Am. Chem. Soc.* **2019**, *141*, 15483–15487.

*C–H Borylation Catalysts that Distinguish Between Similarly Sized Substituents Like Fluorine and Hydrogen*, Miller, S. L.; Chotana, G. A.; Fritz, J. A.; Chattopadhyay, B.; Maleczka, R. E., Jr.; Smith, M. R., III, *Org. Lett.* **2019**, *21*, 6388–6392.

The McCusker Group is interested in the physical and photophysical properties of transition metal complexes. Our approach relies on a confluence of synthetic chemistry, a host of physical techniques ranging from magnetism to femtosecond time-resolved spectroscopy, and high-level theory. The simultaneous examination of chemical problems on all three of these fronts places us in a unique position to explore the physical chemistry of inorganic compounds.

**Ultrafast Spectroscopy of Transition Metal Complexes** – Our research efforts in this area concern the short time scale photo-induced dynamics of transition metal complexes. By “short time scale”, we refer to processes occurring between the time a photon is absorbed by a molecule and the point at which that molecule is fully relaxed in its lowest-lying excited state. Some of the questions we are addressing with this research include the following: (1) what is the general time scale for excited-state evolution in transition metal complexes? (2) what is the mechanism of this process? (3) how do the geometric and electronic structures of the compounds, the surrounding medium, and other factors couple to and/or influence this process? and (4) to what extent can we use this information to control excited-state dynamics? Certain of these questions are very fundamental in nature, whereas others are geared toward work on solar energy conversion. What distinguishes the group, we believe, is our ability to carry out both the synthesis and spectroscopic characterization of a wide range of inorganic molecules. This enables us to systematically examine chemical perturbations to excited-state electronic and

geometric structure, and in so doing develop a comprehensive picture of how transition metal chromophores absorb and dissipate energy.

**Spin and Spin Polarization Effects on Excited-state Dynamics** – Electron spin is a fundamental property of Nature. Although many of the more common physical observables linked to spin are well documented (e.g., magnetism), the degree to which spin and spin polarization influences the chemistry of molecular systems is not as clear. We are pursuing the design and development of chemical systems that will allow us to determine whether there exists a cause-and-effect relationship between the physical and photophysical properties of molecules and their innate spin properties, and if so, to what extent can we exploit this connection in order to manipulate the chemistry of molecular systems. Much of this work centers on the study of so-called donor-acceptor assemblies wherein energy and electron transfer processes are being examined in systems containing spin-coupled paramagnetic fragments. Through careful synthetic manipulation of these compounds, correlations between the observed excited-state reactivity and the involvement of spin-polarized electronic states of the donor and/or acceptor can be realized. Coupled to this experimental work are theoretical studies that exploit recent advances in density functional theory. We believe that these combined efforts will forge an important link between magnetism and electron/energy transfer processes, thereby allowing us to establish a new paradigm in the emerging field of molecular spintronics. 🌐



**James McCusker**

## Synthesis and Spectroscopy of Transition Metal Complexes

### MSU FOUNDATION PROFESSOR

B.S. and M.S.,  
Bucknell Univ.;  
Ph.D.,  
Univ. of Illinois at Urbana Champaign;  
NIH Post-Doctoral Fellow,  
Univ. of North Carolina at Chapel Hill;  
Hellman Faculty Fellow,  
Univ. of California at Berkeley;  
Alfred P. Sloan Fellow;  
Fellow,  
Royal Society of Chemistry.



517-353-1081

### SELECTED PUBLICATIONS

*Leveraging Excited-state Coherence for Synthetic Control of Ultrafast Dynamics*, B.C. Paulus, S.L. Adelman, L.L. Jamula, and J.K. McCusker, *Nature* **2020**, in press.

*Outer-sphere Effects on the Ligand-field Excited-state Dynamics: Solvent Dependence of High-spin to Low-spin Conversion in  $[\text{Fe}(\text{bpy})_3]^{2+}$* , J.N. Miller and J.K. McCusker, *Chem. Sci.* **2020**, *11*, 5191–5204.

*The Influence of Electrolyte Composition on Ultrafast Interfacial Electron Transfer in Fe-sensitized  $\text{TiO}_2$ -based Solar Cells*, C.R. Tichnell, J.N. Miller, C. Liu, S. Mukherjee, E. Jakubikova, and J.K. McCusker, *J. Phys. Chem. C* **2020**, *124*, 1794–1811.

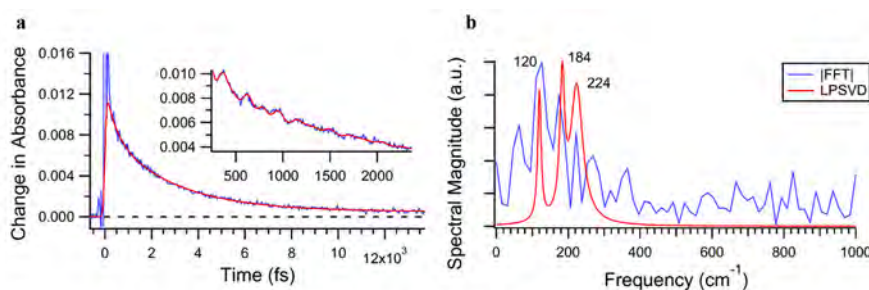
*Electronic Structure in the Transition-metal Block and its Implications for Light Harvesting*, J.K. McCusker, *Science* **2019**, *363*, 484–488.

*Insights into the Excited-state Dynamics of Fe(II) Polypyridyl Complexes from Variable-temperature Ultrafast Spectroscopy*, M.C. Carey, S.L. Adelman, and J.K. McCusker, *Chem. Sci.* **2019**, *10*, 134–144.

*Utilizing Coherence to Enhance Function in Chemical and Biophysical Systems*, G.D. Scholes, G.R. Fleming, L.X. Chen, J.K. McCusker, et al., *Nature* **2017**, *543*, 647–656.

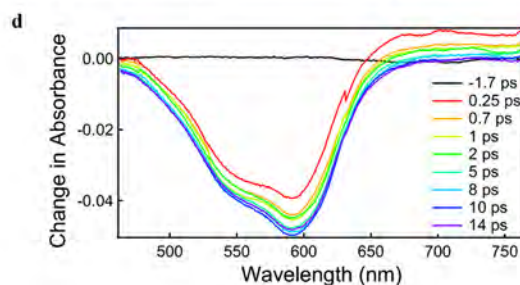
*Photosensitized, Energy Transfer-mediated Organometallic Catalysis through Electronically Excited Ni(II)*, E.R. Welin, C. Le, D.M. Arias-Rotondo, J.K. McCusker, and D.W.C. MacMillan, *Science* **2017**, *355*, 380–385.

*The Photophysics of Photoredox Catalysis: A Roadmap for Catalyst Design*, D.M. Arias-Rotondo and J.K. McCusker, *Chem. Soc. Rev.* **2016**, *45*, 5803–5820 (cover article).



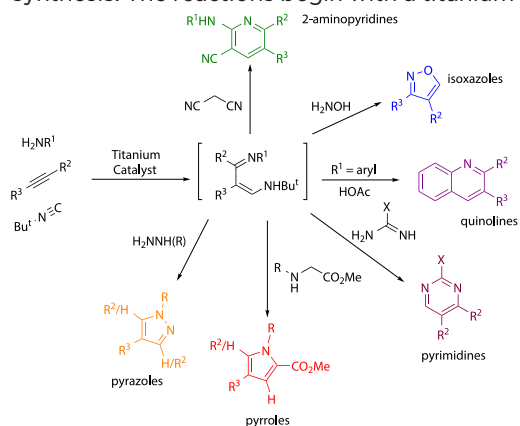
**c** Coherent Vibrational Modes of 2

Frequency, $\text{cm}^{-1}$	116 (3)	183 (2)	220 (4)
Dephasing Time, fs	700 (190)	770 (300)	580 (300)



Finding sustainable and environmentally friendly approaches to complex products is one of the most important challenges facing chemists. Some of the most important methodologies for producing target compounds in fewer, cleaner steps with less waste are catalyzed multicomponent coupling reactions. Our group is interested in developing new methods for the synthesis of biologically active molecules and their applications. In addition, we are interested in the development of tools for catalyst optimization to enable efficient syntheses. In one project, our group is developing titanium-catalyzed multicomponent coupling procedures to make nitrogen-based heterocycles either in a single pot or in a single step. Titanium catalysis is advantageous in that the metal is both abundant and nontoxic.

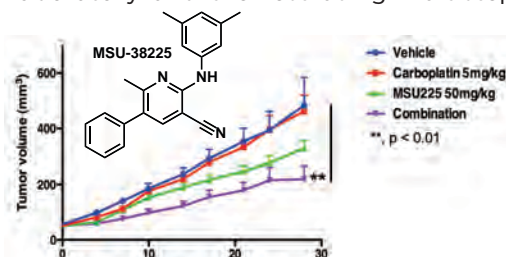
**High Oxidation State Transition Metal Catalysis** – In the exploding diagram are some of the procedures developed for heterocyclic synthesis. The reactions begin with a titanium-



catalyzed multicomponent coupling reaction, alkyne iminoamination, to generate tautomers of 1,3-diimines. In this reaction, a new C–C and C–N bond is formed, and the product need not be isolated. Instead, another reagent can be added to provide substituted heterocycles such as pyridines, isoxazoles, pyrimidines, pyrazoles, pyrroles, and others.

**Applications to Drug Development** – These one-pot, multicomponent coupling reactions produce several privileged structures for biologically active compounds. In collaboration with the Liby group in the Pharmacology and Toxicology Department, we are exploring novel NRF2 inhibitors based on the 2-aminopyridine framework. The NRF2 signaling pathway is activated by cellular stress and plays a key role in controlling cellular response to reactive oxygen and nitrogen species, in addition to other toxic substances. In general, NRF2 activation is beneficial as a protective against damaging species that may invade the cell; however, some types of cancers (~30% of lung cancers, for example) contain constitutively activated

NRF2 pathways, leading to the cancer cells being less susceptible to chemotherapeutics and radiotherapy. In these cases, NRF2 inhibition can be used to make these cells more susceptible to common chemotherapeutics, like carboplatin. In a recent study, we prepared ~50 derivatives of the hit inhibitor compound MSU38225, where about half of these new substituted pyridines were prepared using the titanium chemistry developed in our laboratory and the rest using multistep



palladium- and copper-catalyzed coupling reactions. This resulted in the discovery of a more potent compound with better pharmacological properties. In the figure are shown the results of a xenograph experiment performed in the Liby lab where human lung tumors with a constitutively-activated NRF2 pathway (A549) on mice were treated with a low dose of carboplatin (no discernable effect), MSU38225 (slower tumor growth), or a combination of the two, which dramatically slowed tumor growth. This close collaboration with the Liby group is continuing as we seek more potent compounds, identification of the biological target, and applications of these new NRF2 pathway inhibitors.

**Catalyst Development Using Reaction Modeling** – To evaluate ligands for early transition metal catalysis, like in the project above, we have developed a chromium(VI), d<sup>0</sup>-system that is very synthetically versatile, NCr(NiPr<sub>2</sub>)<sub>2</sub>X, where X is the ligand under scrutiny. Using this system, we parameterize ligands based on their sterics and electronics. In one application, we were able to model the reactivity of a series of titanium hydroamination catalysts and determine quantitatively how the sterics and electronics of the ancillary ligand contributes to reaction rate. Once the model was established, we could anticipate what the reaction rate would be in many cases. This methodology is now being applied to a wide range of different catalytic systems to better understand structure-activity relationships between ancillary ligands and catalytic outcomes.

In these projects, and others, we are attempting to widen and optimize the applications of Earth-abundant transition metals, and we are investigating new possibilities for applications in human health and other areas. 🌱



**Aaron L. Odom**

**Organometallic/  
Inorganic Synthesis  
and  
Transition Metal  
Catalysis in Organic  
Synthesis**

**PROFESSOR**

B.S.,  
Texas Tech Univ.;

Ph.D.,

Massachusetts Institute of Technology;

Postdoctoral Research Fellow,

Massachusetts Institute of Technology.



517-353-1073

**SELECTED PUBLICATIONS**

*A Novel NRF2 Pathway Inhibitor Sensitizes KEAP1-Mutant Lung Cancer Cells to Chemotherapy*, Zhang, D.; Hou, Z.; Aldrich, K. E.; Lockwood, L.; Odom, A. L.; Liby, K. T., *Mol. Cancer Ther.* **2021**, *20*, 1692-1701.

*Quantifying Ligand Effects in High-Oxidation-State Metal Catalysis*, Billow, B. S.; McDaniel, T. J.; Odom, A. L., *Nature Chem.* **2017**, *9*, 837-842.

*Titanium-Catalyzed Multicomponent Couplings: Efficient One-Pot Syntheses of Nitrogen Heterocycles*, Odom, A. L.; McDaniel, T., *J. Acc. Chem. Res.* **2015**, *48*, 2822-33.

*A Single Complex with Chromium-Nitrogen Single, Double, and Triple Bonds: Synthesis, Structure and Reactivity*, Beaumier, E. P.; Billow, B. S.; Singh, A. K.; Biros, S. M.; Odom, A. L., *Chem. Sci.* **2016**, *7*, 2532-2536.

*A 4-Coordinate Ru(II) Imido: Unusual Geometry, Synthesis, and Reactivity*, Singh, A. K.; Levine, B. G.; Staples, R. J.; Odom, A. L., *Chem. Commun.* **2013**, *49*, 10799-801.

*Titanium-Catalyzed, One-Pot Synthesis of 2-Amino-3-Cyanopyridines*, Dissanayake, A. A.; Odom, A. L., *Adv. Synth. Cat.* **2014**, *356*, 1811-1822.

*Substituted Quinolines as Noncovalent Proteasome Inhibitors*, McDaniel, T. J.; Lansdell, T. A.; Dissanayake, A. A.; Azevedo, L.; Claes, J.; Odom, A. L.; Tepe, J. J., *Bioorganic and Medicinal Chemistry* **2016**, *24*, 2441-2450.

*Investigation of Phosphine Donor Properties to Vanadium(V) Nitriles*, Mo, L.; Barr, H. I.; Odom, A. L., *Results in Chem.* **2022**, *4*, 100344.



**Thomas V. O'Halloran**

## Transition Metal Chemistry of Living Systems and Medicine

UNIVERSITY FOUNDATION PROFESSOR OF CHEMISTRY AND PROFESSOR OF MICROBIOLOGY & MOLECULAR GENETICS

B.S., M.S., Univ. of Missouri;  
Ph.D., Columbia Univ.;  
Postdoctoral Fellow, Massachusetts Inst. of Technology;

517-353-4090



### SELECTED PUBLICATIONS

*Metal Ion Fluxes Controlling Amphibian Fertilization*, Seeler, J.F.; Sharma, A.; Zaluzeck, N.J.; Bleher, R.; Lai, B.; Schultz, E. G.; Hoffman, B.M.; LaBonne, C.; Woodruff, T. K.; O'Halloran, T. V., *Nat. Chem.* **2021**, *13*, 683-691.

*CueR Activates Transcription through a DNA Distortion Mechanism*, Fang, C.; Phillips, S.J.; Wu, X.; Chen, K.; Shi, J.; Shen, L.; Xu, J.; Feng, Y.; O'Halloran, T.V.; Zhang, Y., *Nat. Chem. Biol.* **2021**, *17*, 57-64.

*Interrogating Intracellular Zinc Chemistry with a Long Stokes Shift Zinc Probe ZincBY-4*, Garwin, S.A.; Kelley, M.S. J.; Sue, A.C.; Que, E. L.; Schatz, G.C.; Woodruff, T.K.; O'Halloran, T.V., *J. Am. Chem. Soc.* **2019**, *141*, 16696-16705.

*Arsenoplatin-1 Is a Dual Pharmacophore Anticancer Agent*, Miodragović, Đ.; Merlino, A.; Swindell, E.P.; Bogachkov, A.; Ahn, R. W.; Abuhadba, S.; Ferraro, G.; Marzo, T.; Mazar, A.P.; Messori, L.; O'Halloran, T.V., *J. Am. Chem. Soc.* **2019**, *141*, 6453-6457.

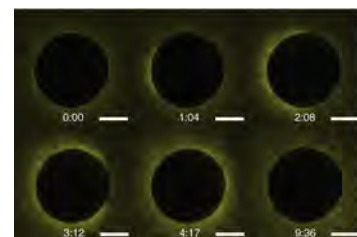
*Allosteric Transcriptional Regulation via Changes in the Overall Topology of the Core Promoter*, Phillips, S.J.; Canalizo-Hernandez, M.; Yildirim, I.; Schatz, G.C.; Mondragon, A.; O'Halloran, T.V., *Science* **2015**, *349*, 877-881.

*Quantitative Mapping of Zinc Fluxes in the Mammalian Egg Reveals the Origin of Fertilization-Induced Zinc Sparks*, Que, E. L.; Bleher, R.; Duncan, F.E.; Kong, B.Y.; Gleber, S.C.; Vogt, S.; Chen, S.; Garwin, S. A.; Bayer, A.R.; Dravid, V.P.; Woodruff, T.K.; O'Halloran, T.V., *Nat. Chem.* **2015**, *7*, 130-139.

The O'Halloran laboratory focuses on developing a quantitative understanding of the regulatory roles of transition metals in controlling cellular physiology. Each cell must acquire millions (bacteria) to billions (eukaryotes) of metal ions, monitor, and balance the levels of these ions to prevent excessive accumulation while simultaneously keeping metals flowing into essential catalytic and signaling processes. My highest priority is training the next generation of scientists to become rigorous and creative experts who can guide discovery at the interface of the physical and biological sciences. The transdisciplinary training in my lab both prepares and enables students to solve some of the most challenging and pressing problems in chemical, biological, and biomedical research.

**Quantitative Inorganic Physiology** - Imagine being able to count the atoms of the essential elements from the single-cell level, in subcellular compartments, and at the tissue-level. Then imagine measuring the changes in the distribution and activity of metal ions in response to environmental and developmental signals as cellular cues for fundamental processes. This nascent field of inorganic physiology intersects the traditional disciplines of chemistry and biology and harmonizes with cutting-edge elemental mapping technologies developed with physicists and analytical chemists at the helm. We are developing quantitative analytical techniques along several thrusts, including single-cell mass spectrometry, X-ray fluorescence microscopy, and laser ablation time-of-flight mass spectrometry.

**Regulatory Metal Fluxes Controlling Cell Cycle Progression** - Using our new zinc-specific probes and synchrotron X-ray fluorescence microscopy, we developed novel imaging methods and discovered that zinc fluxes in the mammalian egg regulate both the exit from the meiotic cell cycle and the resumption of mitosis upon fertilization. Most strikingly, fertilization of a mammalian egg initiates a series of 'zinc sparks', rapid exocytosis of over 10 billion zinc ions, that are necessary to induce the egg-to-embryo transition. Very recently, we have discovered



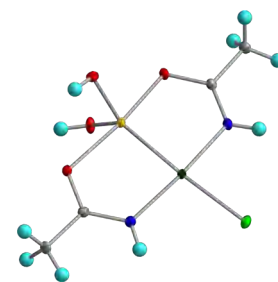
**Metal fluxes controlling fertilization.** Left: live-cell fluorescence zinc imaging demonstrates that fertilization of *X. laevis* oocytes induces a zinc spark, which was first observed in mammalian models (Seeler et al., *Nat. Chem.* **2021**). Middle and Right: to quantify and map labile pools of metals, our lab develops metal-responsive probes, such as the ZincBY family of zinc-responsive fluorescent probes (Garwin et al. *J. Am. Chem. Soc.* **2019**).



**Preliminary quantitative elemental maps of the mouse coronal brain.** Green regions correspond to high concentrations of Zn, especially prevalent in the hippocampal formation. Blue regions correspond to Cu enrichment in periventricular zones (also enriched in stem cells), and red areas indicate Fe abundance (Kozorovitskiy and O'Halloran, unpublished data).

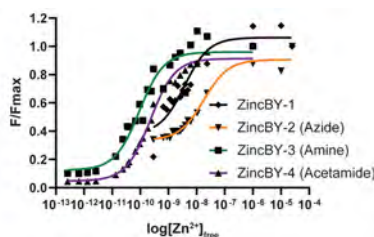
that zinc sparks are not only conserved in the amphibian *Xenopus laevis*, but fertilization also triggers a loss of intracellular manganese to prevent polyspermy.

**Biological Inorganic Chemistry of Cancer** - Insights into the inorganic chemistry of the cell have led to the development of new therapeutic agents. Cisplatin and arsenic trioxide are anti-cancer drugs that both induce apoptotic cell death, but through different biochemical pathways. To improve the efficacies of these two drugs, the O'Halloran group utilized a nanomaterials approach to



**Crystal structure of arsenoplatin-1, a unique dual pharmacophore anticancer agent** (Miodragović et al., *J. Am. Chem. Soc.* **2019**).

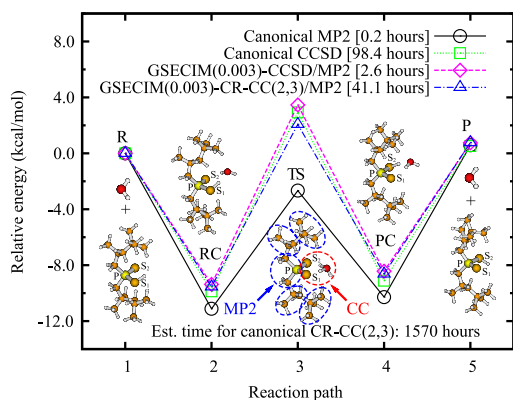
co-encapsulate high levels of arsenous acids and aqua-cisplatin into 100 nm liposomes that are stable in serum but release their drug in the low-pH endosome of tumor cells. In a separate coordination chemistry approach, we developed arsenoplatin, an arsenous acid-platinum complex that shows significant biological activity in several cancer cell lines and with activity distinct from cisplatin and arsenic trioxide individually. ☘



My research program focuses on (i) *ab initio* quantum theory of molecular electronic structure and other many-body systems, (ii) molecular properties, spectroscopy, and photochemistry, (iii) reaction mechanisms and dynamics, and (iv) theory of intermolecular forces. We design and apply quantum-mechanical methods that enable precise determination of potential energy surfaces and property functions for both existing and hypothetical molecular species in their ground and excited states. We are also interested in accurate quantum calculations for strongly correlated systems, weakly interacting molecular clusters, and atomic nuclei.

### Quantum theory of molecular electronic structure.

The key to understanding molecular electronic structure and dynamical behavior of molecules is an accurate assessment of the many-electron correlation effects. Our group focuses on the development and applications of new quantum-mechanical methods that include correlation, particularly on the coupled-cluster theory and its renormalized, active-space, extended, multi-reference, externally corrected, equation-of-motion, and linear-response variants



that allow us to study bond breaking, electronically excited states, electron-transfer processes, molecular properties in vibrationally and electronically excited states, and transition probability coefficients for various types of spectroscopy. We examine ways of achieving high-level coupled-cluster or numerically exact energetics by combining deterministic computations with stochastic wave function sampling. We also develop approximate coupled-pair approaches for strongly correlated systems and local correlation coupled-cluster methods and their multi-level extensions that can be applied to high accuracy *ab initio* calculations for systems with hundreds of atoms. Our primary interest is in high-accuracy methods that allow us to be predictive. We write computer codes for the standard and new coupled-cluster methods which are distributed world-wide through a popular electronic structure package GAMESS and plugins to PSI4 available on GitHub. Some of our methods are also available in NWChem, Q-Chem, and MRCC packages.

### Many-body methods of quantum mechanics and nuclear physics.

We demonstrated that quantum-chemistry-inspired coupled-cluster methods can be applied to atomic nuclei. We performed several highly successful *ab initio* coupled-cluster

calculations for  ${}^4\text{He}$ ,  ${}^{16}\text{O}$ ,  ${}^{24}\text{O}$ ,  ${}^{40}\text{Ca}$ , and open-shell systems around  ${}^{16}\text{O}$  using modern nucleon-nucleon interactions. We also carried out widely publicized coupled-cluster calculations for  ${}^{56}\text{Ni}$  and its isotopes. We are looking for the alternative approaches to accurate calculations for many-fermion systems with pair-wise interactions, including the use of cluster expansions involving two-body correlation operators to represent nearly exact many-fermion states.

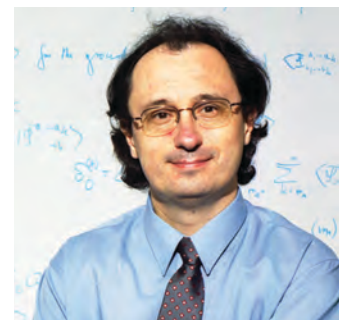
### Molecular properties, spectroscopy, and photochemistry.

We use linear-response coupled-cluster methods, along with other *ab initio* approaches, to calculate molecular multipole moments and (hyper)polarizabilities and the effect of nuclear motion on these properties. We use first-principles theories to obtain rovibrational, electronic, and rovibronic spectra of molecules and weakly bound species. We demonstrated that the lowest excited state of methylcobalamin should be interpreted as metal-to-ligand charge-transfer excitation and that azulene possesses the doubly excited state below the ionization threshold, which can drive multiphoton ionization experiments related to Rydberg fingerprint spectroscopy. We provided definitive information about structural, electronic, and spectroscopic properties of several organic biradicals and small metal nanoparticles, including, for example, beryllium, magnesium, silver, and gold clusters. We also explained the origin of the experimentally observed photoemission bands associated with the boron vacancy defects in hexagonal boron nitride.

### Reaction mechanisms and dynamics.

We performed successful computational studies for several important organic chemistry reactions, including the Cope rearrangement of 1,5-hexadiene, cycloaddition of cyclopentyne to ethylene, thermal stereomutations of cyclopropane, and isomerization of bicyclo[1.1.0]butane to buta-1,3-diene. We carried out unprecedented coupled-cluster calculations for  $\text{CuO}_2$  and  $\text{Cu}_2\text{O}_2$  systems, relevant to oxygen activation by metalloenzymes, for photoisomerizations of acetylacetone, for diffusion of atomic oxygen on the silicon surface, for proton-transfer reactions between the dithiophosphinic acids and water molecules, for aerobic oxidation of methanol on gold nanoparticles, and for the Co-C bond dissociation in methylcobalamin, relevant to catalytic properties of  $\text{B}_{12}$ . We also studied light-induced reactions involving super photobase abbreviated as FRO-SB, capable of abstracting protons from alcohols, and photo-induced charge-transfer reactions between alkali metal atoms and halides. In particular, we combined *ab initio* and dynamical approaches to characterize quasi-bound states of van der Waals molecules that are precursors of these reactions.

**Intermolecular interactions.** Intermolecular potentials are a necessary ingredient for the determination of the structure, stability, and dynamics of weakly bound clusters and condensed phases. We are interested in many-body interactions, which are important when three or more atoms or molecules interact, and study interactions in dimers. ☘



Piotr Piecuch

## Quantum Chemistry and Physics

UNIVERSITY  
DISTINGUISHED PROFESSOR  
AND  
MSU FOUNDATION PROFESSOR  
AND  
ADJUNCT PROFESSOR OF PHYSICS

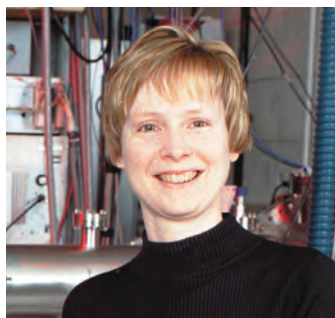
M.Sc., 1983, Univ. of Wrocław (Poland);  
Ph.D., 1988, Univ. of Wrocław;  
Postdoctoral Fellow, 1988-91,  
Univ. of Waterloo (Canada);  
Assistant Professor, 1990-92, Univ. of Wrocław;  
Postdoctoral Associate, 1992-93,  
Univ. of Arizona;  
Visiting Assistant Professor, 1994-95,  
Univ. of Waterloo;  
Visiting Assistant Professor, 1995-97,  
Univ. of Toronto;  
Postdoctoral Associate, 1997-98,  
Univ. of Florida;  
Adjunct Assistant Professor, 2000-03,  
Univ. of Waterloo;  
Alfred P. Sloan Research Fellow, 2002-04;  
Invited Fellow of JSPS and Vis. Prof., 2005,  
Kyoto Univ. (Japan);  
Vis. Prof., Univ. of Coimbra (Portugal), 2006;  
Elected Member, Eur. Acad. of Arts,  
Sciences and Humanities, Paris, France, 2003;  
Fellow of the American Physical Society, 2008;  
Fellow of the American Association for the  
Advancement of Science, 2011;  
Invited Prof., Inst. for Molecular Science,  
Okazaki (Japan), 2012-13;  
Distinguished Fellow, Kosciuszko Foundation  
Collegium of Eminent Scientists, 2015;  
Clark Way Harrison Distinguished Visiting  
Professor, Washington Univ. in St. Louis, 2016;  
Fellow of the Royal Society of Chemistry, 2016;  
Elected Member, International Academy of  
Quantum Molecular Science, 2018.



517-353-1151

### SELECTED PUBLICATIONS

- High-Level Coupled-Cluster Energetics by Monte Carlo Sampling and Moment Expansions: Further Details and Comparisons*, J.E. Deustua, J. Shen, and P. Piecuch, *J. Chem. Phys.* **2021**, 154, 124103.
- Is Externally Corrected Coupled Cluster Always Better than the Underlying Truncated Configuration Interaction?*, I. Magoulas, K. Gururangan, P. Piecuch, J.E. Deustua, and J. Shen, *J. Chem. Theory Comput.* **2021**, 17, 4006.
- Controlling Quantum Interference between Virtual and Dipole Two-Photon Optical Excitation Pathways Using Phase-Shaped Laser Pulses*, J. Lahiri et al., *J. Phys. Chem. A* **2021**, 125, 7534.
- Double Electron-Attachment Equation-of-Motion Coupled-Cluster Methods with up to 4-particle-2-hole Excitations: Improved Implementation and Application to Singlet-Triplet Gaps in ortho-, meta-, and para-Benzene Isomers*, J. Shen and P. Piecuch, *Mol. Phys.* **2021**, 119, e1966534.
- Internal Conversion between Bright ( ${}^1B_u$ ) and Dark ( ${}^2A_g$ ) States in s-trans-Butadiene and s-trans-Hexatriene*, W. Park, J. Shen, S. Lee, P. Piecuch, M. Filatov, and C.H. Choi, *J. Phys. Chem. Lett.* **2021**, 12, 9720.
- High-Level Coupled-Cluster Energetics by Merging Moment Expansions with Selected Configuration Interaction*, K. Gururangan, J.E. Deustua, J. Shen, and P. Piecuch, *J. Chem. Phys.* **2021**, 155, 174114.
- Addressing Strong Correlation by Approximate Coupled-Pair Methods with Active-Space and Full Treatments of Three-Body Clusters*, I. Magoulas, J. Shen, and P. Piecuch, *Mol. Phys.* **2022**, XXX, e2057365.



## Lynmarie A. Posey

### Mathematics in Chemistry Education

ASSOCIATE DEAN FOR UNDERGRADUATE STUDIES

AND

ASSOCIATE PROFESSOR

B.S.,  
Davidson College;

Ph.D.,  
Yale Univ.;

NSF Postdoctoral Research Fellow,  
Stanford Univ.;

Assistant Professor,  
Associate Professor,  
Vanderbilt Univ.

517-353-1193



#### SELECTED PUBLICATIONS

*Characterizing college science instruction: The Three-Dimensional Learning Observation Protocol*, Bain, K., et al., *PLoS ONE* **2020**, 15(6): e0234640. <https://doi.org/10.1371/journal.pone.0234640>.

*Mathematical knowledge for teaching in chemistry: Identifying opportunities to advance instruction*, Posey, L. A.; Bieda, K. N.; Mosley, P. L.; Fessler, C. J.; Kuechle, V. A. B., in *It's Just Math: Research on Students' Understanding of Chemistry and Mathematics (ACS Symposium Series)*; Towns, M., Bain, K., Rodriguez, J.-M., Eds.; American Chemical Society: Washington, DC, **2019**, 135-155. <https://pubs.acs.org/doi/10.1021/bk-2019-1316.ch009>.

*Helping students to "do science": Characterizing scientific practices in general chemistry laboratory curricula*, Carmel, J. H.; Herrington, D. G.; Posey, L. A.; Ward, J. S.; Pollock, A. M.; Cooper, M. M. *J. Chem. Educ.* **2019**, 96, 423-434. <https://pubs.acs.org/doi/full/10.1021/acs.jchemed.8b00912>.

*Evaluating the extent of a large-scale transformation in gateway science courses*, Matz, R. L.; Fata-Hartley, C. L.; Posey, L. A.; Laverty, J. T.; Underwood, S. M.; Carmel, J. H.; Herrington, D. G.; Stowe, R. L.; Caballero, M. D.; Ebert-May, D.; Cooper, M. M., *Sci. Adv.* **2018**, 4, eaau0554. <https://pubmed.ncbi.nlm.nih.gov/30397646/>.

*Adapting assessment tasks to support three-dimensional learning*, Underwood, S. M.; Posey, L. A.; Herrington, D. G.; Carmel, J. H.; Cooper, M. M., *J. Chem. Educ.* **2018**, 95, 207-217. <https://pubs.acs.org/doi/full/10.1021/acs.jchemed.7b00645>.

*Core ideas and topics: Building up or drilling down?*, Cooper, M. M.; Posey, L. A.; Underwood, S. M., *J. Chem. Educ.* **2017**, 94, 541-548. <https://doi.org/10.1021/acs.jchemed.6b00900>.

## Building Chemistry and Mathematics Understanding at the Introductory Level

In 2012, the President's Council of Advisors on Science and Technology (PCAST) reported that one million additional college graduates with STEM degrees would be needed over the next 10 years to meet the anticipated demand for technically skilled workers. Unfortunately, many students interested in pursuing STEM careers enter college without the background and skills required to succeed in general chemistry, which is often the first required science course. In fact, fewer than 40% of the students who enter college as STEM majors graduate with a STEM degree.

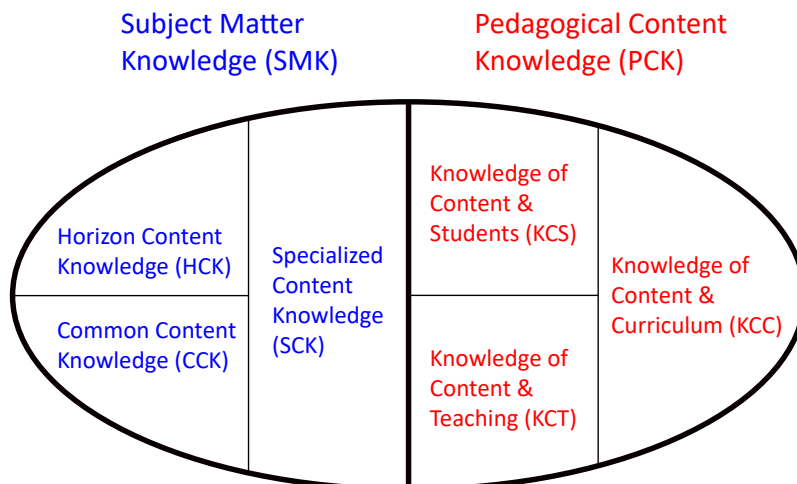
Developmental chemistry courses to support underprepared students have typically focused on drilling algorithmic problem-solving rather than on helping students to construct an understanding of core ideas in chemistry and make meaning of the supporting mathematics. We are studying a new approach built around core ideas in chemistry: 1) bonding and electrostatic interactions, 2) structure and properties of matter, and 3) energy. Since learning is a developmental process, we aim to help students build increasingly complex and scientifically correct understanding of these core ideas, which is both transferable and robust, by carefully scaffolding their learning on existing knowledge. We blend scientific practices (using models, constructing scientific explanations, and applying mathematical thinking) with content in instruction to further support students in building and using their knowledge. We are studying the impact of this novel approach to developmental chemistry on student motivation, self-efficacy, science identity, and success in general chemistry.

We have found that even when scientific practices largely replace traditional chemistry calculations, student success in

our developmental chemistry course strongly correlates with mathematics background. Students in our course often struggle with the same mathematics that students in non-credit-bearing-remedial (NCBR) algebra courses find most challenging. These topics include: 1) proportional reasoning; 2) linear rates of change and interpreting the rate of change from a graph; 3) modeling of covarying relationships with functions; and 4) translating between multiple representations. In collaboration with mathematics education researchers, we are developing and studying the impact of interventions that use multiple representations to build student understanding of mathematics used in college chemistry courses at the introductory level.

## Mathematical Knowledge for Teaching in Chemistry

A cross-disciplinary team is undertaking a study to characterize the mathematical knowledge for teaching (MKT) needed to effectively teach the mathematics used in general chemistry courses for STEM majors. MKT is comprised of mathematics subject matter knowledge (SMK) and pedagogical content knowledge (PCK) unique to the work of teaching (see Figure below). PCK includes knowledge of content and students (KCS) such as how students learn mathematics as well as their understandings and misunderstandings, knowledge of content and teaching (KCT), i.e. mathematics pedagogy, and knowledge of content and curriculum (KCC). While most chemistry instructors possess strong SMK in mathematics, their PCK is often less developed. Our work will inform efforts to build chemistry instructors' MKT to increase the effectiveness of mathematics instruction in support of chemistry learning. Data sources for this project include analysis of general chemistry textbooks, video-recorded observations of classroom instruction, and instructor interviews. 🌱

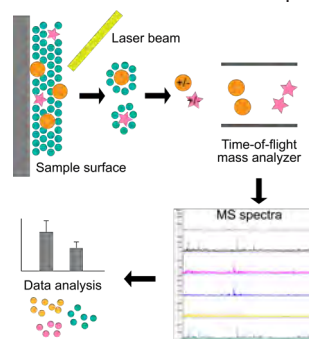


*Domains of Mathematical Knowledge for Teaching, after Ball, Thames, and Phelps, J. Teach. Educ.* **2008**, 59, 389-407.



Humans and other living organisms in the environment routinely experience a variety of environmental factors from dietary uptake to pollutant exposure. Microbiome, collection of microorganisms, plays critical roles in mediating how environmental factors affect health and diseases. Particularly, intriguing roles of animal microbiome in regulating host nervous systems, namely the microbiome-gut-brain axis, have drawn much attention in recent years for understanding disease mechanisms and its promising applications in future biomedicine. With tools from analytical chemistry, toxicology, microbiology and neuroscience, the Qiu lab is interested in elucidating the chemical basis of environment-host-microbe interactions with an emphasis on the microbiome-gut-brain axis and linking the chemical and molecular mechanisms to animal physiology and behavior.

**Mass spectrometry methods for microbiome-gut-brain axis** – Altered microbiota are correlated to various neurological diseases from enteric to central nervous systems. Gut microbial species can affect host nervous system via many pathways, including regulating levels of neurochemicals from classical biogenic amines to neuropeptides and hormones. One primary research goal of the Qiu lab is to develop mass spectrometry-based methods for neurochemicals from gut microbes and in animal samples. With matrix-assisted laser desorption/ionization (MALDI) coupled with a time-of-flight (TOF) mass analyzer (**Figure 1**), MALDI-TOF mass spectrometry provides capabilities to visualize the spatial distribution of

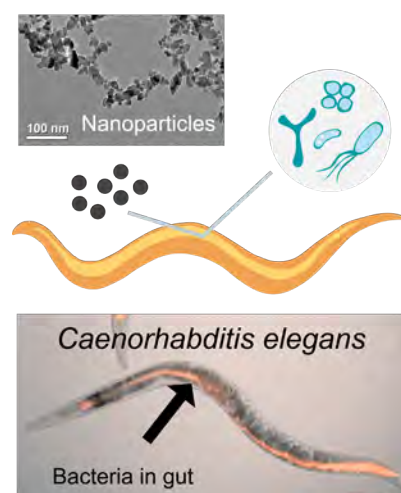


**Figure 1. Illustration for the working principle of a MALDI-TOF mass spectrometer.**

chemicals and screen chemical contents in a high-throughput manner. Liquid chromatography coupled with various mass spectrometers (LC-MS) can be used for structural analysis and quantification of analytes. Together with microbiology techniques and animal models, these mass spectrometry-based methods will help us to understand the chemical basis of the microbiome-gut-brain axis and explore their potential for future microbiome-based neurological disease interventions.

**Environmental toxicology research for nanotechnology** – Microbiome can mediate the effects of environmental pollutants on human

health and the ecosystem. The extremely small size ( $10^{-9}$  m) of engineered nanoparticles (ENPs) gives them high reactivities and unique properties desirable in many emerging technologies, enabling future markets of billions. However, the risk of these reactive materials to environment needs to be thoroughly investigated to prevent negative consequences. Another focus area of the Qiu lab is to understand how microbiome mediates ENP toxicity to animals with an emphasis on neurotoxicity. Utilizing the powerful model animal, the nematode *Caenorhabditis elegans* (*C. elegans*), and various microbial models, we aim use a nano-host-microbe experimental scheme and combine interdisciplinary approaches to discover important molecular mechanisms in gut microbiome-mediated ENP toxicity to animals (**Figure 2**), providing guidance for the involvement of microbiota in future environmental risk assessment.



**Figure 2. A nano-host-microbe experimental scheme, illustrating the nematode *C. elegans* with bacteria residing in gut as well as a TEM image of  $\text{TiO}_2$  nanoparticles.**

**Bacterial cell wall, high glucose exposure and aging** – High glucose exposure can cause toxicity that is related to obesity and type 2 diabetes, diseases correlated with aging and reduced lifespan. A widely used model for aging studies, *C. elegans* has well-conserved signaling pathways implicative of aging in human. High glucose was shown to reduce *C. elegans* lifespan, and our previous study showed that the bacterial diet fed to *C. elegans* could mediate glucose-induced lifespan reduction via enzymatic activities related to bacterial cell wall synthesis. We aim to further extend the research to understand the molecular mechanisms of the interactions among high glucose exposure, bacterial cell wall structure and aging using our interdisciplinary approaches from mass spectrometry to *C. elegans* biology. With increasing sugar consumption being a public health issue, we hope this research can shed light on how microbiome may regulate hosts' response to high glucose exposure and pave ways for future microbiome-involved interventions and evaluations for sugar consumption risks and related diseases. 🍷



**Tian (Autumn) Qiu**

**Analytical Chemistry,  
Environmental  
Toxicology,  
Microbiome-Gut-  
Brain Axis**

**ASSISTANT PROFESSOR**

B.S.,

Peking Univ.;

Ph.D.,

Univ. of Minnesota-Twin Cities

Beckman Postdoctoral Fellow,

Postdoctoral Research Associate,

Univ. of Illinois at Urbana-Champaign.



517-355-9715

**SELECTED PUBLICATIONS**

*Identifying sources of D-serine in Caenorhabditis elegans and their impact on behavior*, TA Qiu, HM Andersen, NJ Larson, NE Schroeder, JV Sweedler, **2021**, Preprint on *ChemRxiv*: doi.org/10.33774/chemrxiv-2021-mz0t.

*Profiling of D-alanine production by the microbial isolates of rat gut microbiota*, CJ Lee, TA Qiu, Z Hong, Z Zhang, Y Min, L Zhang, L Dai, H Zhao, T Si, **2021**, Under revision. Preprint on *ChemRxiv*: doi.org/10.33774/chemrxiv-2021-r55x3.

*Nanoscale battery cathode materials induce DNA damage in bacteria*, Qiu, T. A., et al., *Chemical Science* **2020**, *11*, 11244-11258.

*Linking nanomaterial properties to biological outcomes: analytical chemistry challenges in nanotoxicology for the next decade*, Qiu, T. A., Clement, P. L., Haynes, C. L., *Chem. Commun.* **2018**, *54*, 12787-12803.

*Growth-based bacterial viability assay for interference-free and high-throughput toxicity screening of nanomaterials*, Qiu, T. A., et al., *Anal. Chem.* **2017**, *89*, 2057-2064.

*Quantification of free polyelectrolytes present in colloidal suspension, revealing source of toxic responses for polyelectrolyte-wrapped gold nanoparticles*, Qiu, T. A., et al., *Anal. Chem.* **2017**, *89*, 1823-1830.



## Gregory W. Severin Radiochemistry

### ASSISTANT PROFESSOR

B.S., Physics,  
Univ. of Illinois, Urbana-Champaign;  
M.S. Chemistry,  
Univ. of Wisconsin-Madison;  
Ph.D., Experimental Nuclear Physics,  
Univ. of Wisconsin-Madison;  
Researcher,  
Technical Univ. of Denmark;  
Senior Researcher,  
Technical Univ. of Denmark.

517-353-1087

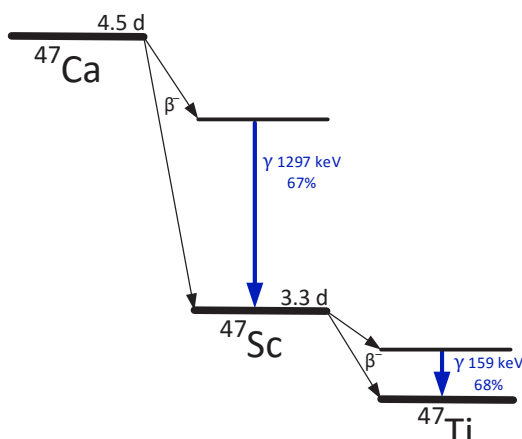


Radionuclides are important tools for tracing biological, chemical, and physical processes. The National Superconducting Cyclotron Laboratory (NSCL) and the upcoming Facility for Rare Isotope Beams (FRIB) have the potential to supply unique radioisotopes that are otherwise difficult to produce. The challenge of obtaining these rare isotopes from NSCL and FRIB is in the need for rigorous chemical or physical purification of sub-nanogram quantities of individual elements from a complex mixture of spallation and fragmentation products. The purpose of my research is to parse and purify the stock of co-produced radionuclides to obtain both high radionuclidic purity and high specific activity for application in basic science, medical, chemical and biological research. Of particular interest are transition and rare earth radiometals for use in the development of new diagnostics and therapeutics against invasive disease.

**Radiometals in Medicine** – Research into the molecular identity of cancerous and other malignant cells has identified biological vectors that can seek out disease sites in vivo. In order to trace the biodistributions and pharmacokinetics of these new vectors, preclinical Positron Emission Tomography (PET) has expanded beyond the organic and pseudo-organic radionuclides ( $^{11}\text{C}$ ,  $^{13}\text{N}$ ,  $^{14,15}\text{O}$ ,  $^{18}\text{F}$ ) to include a host of longer-lived and unconventional radiometals (e.g.  $^{44}\text{Sc}$ ,  $^{45}\text{Ti}$ ,  $^{52}\text{Mn}$ ,  $^{64}\text{Cu}$ ,  $^{89}\text{Zr}$ , and  $^{140}\text{Nd}$ ). Beyond receptor- and epitope-based PET, radiometals also facilitate development of metal-based drugs, allow tracing of the native and mimetic nature of metals in the body, can be used to track

nanoparticle drug delivery vehicles, and in some cases have unique exploitable decay properties (e.g.  $^{140}\text{Nd}$  in Figure 1 below). Further, the diagnostic metals are often isotopically matched to therapeutic nuclides, motivating a rapid transition from diagnostic imaging to targeted radionuclide therapy.

A new water-cooled beamstop at NSCL will provide access to a selection of radiometals including  $^{47}\text{Sc}$ , a therapeutic analog to the positron emitter  $^{44}\text{Sc}$ .  $^{47}\text{Sc}$  forms following  $^{47}\text{Ca}$  decay (Figure 2), which is co-produced in high yield during  $^{48}\text{Ca}$  irradiations at NSCL.



**Figure 2:** A simplified decay scheme for  $^{47}\text{Ca}$  and  $^{47}\text{Sc}$ . The low energy beta particles from  $^{47}\text{Sc}$  are therapeutic, and the 159 keV gamma ray has an appropriate energy for imaging with single photon computed tomography (SPECT).

Isolation of  $^{47}\text{Ca}$  allows production of a  $^{47}\text{Sc}$  generator that extends the usable lifetime of  $^{47}\text{Sc}$  in addition to providing it in high purity and with high specific activity. 🌟

### SELECTED PUBLICATIONS

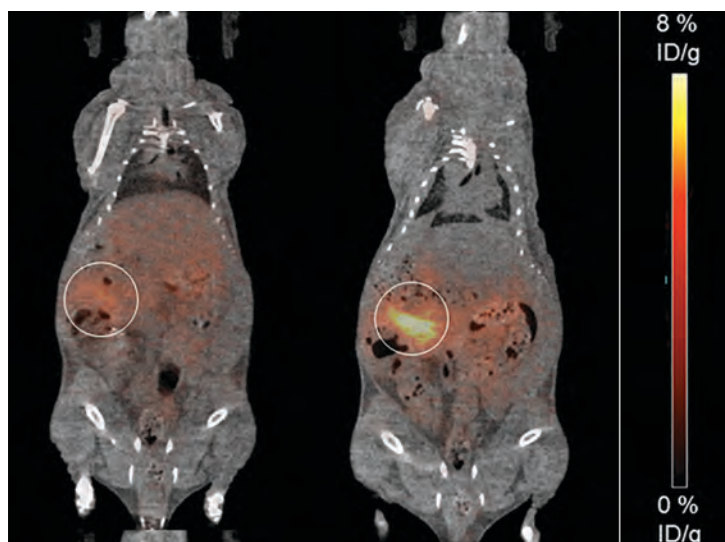
*ImmunoPET/MR imaging enables specific detection in vivo of Aspergillus fumigatus infection*, Rolfe, A-M, et al., *Proc Natl Acad Sci* **2016**, 113(8), E1026–E1033.

*Measurement of the branching ratio for the beta decay of  $^{14}\text{O}$* , Voytas PA, et al., *Phys. Rev. C* **2015**, 92, 065502.

*Novel Preparation Methods of  $^{52}\text{Mn}$  for ImmunoPET Imaging*, Graves, SA et al., *Bioconjug. Chem.* **2015**, 26(10), 2118–2124.

*Bringing radiotracing to titanium-based antineoplastics: solid phase radiosynthesis, PET and ex-vivo evaluation of antitumor agent [ $^{45}\text{Ti}$ ](salan)Ti(dipic)*, Severin, GW et al., *J. Med. Chem.* **2015**, 58(18), 7591–7595.

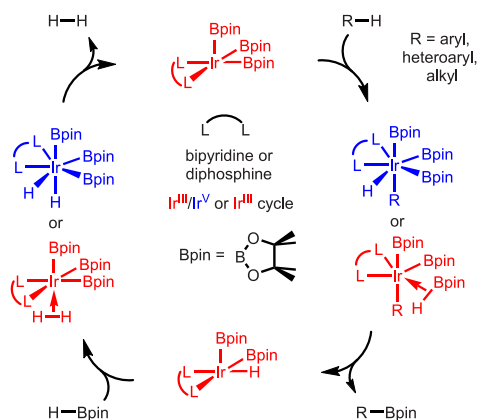
*The impact of weakly bound  $^{89}\text{Zr}$  on pre-clinical studies: Non-specific accumulation in solid tumors and aspergillus infection*, Severin, GW et al., *Nucl. Med. Biol.* **2015**, 42(4), 360–368.



**Figure 1:** (left) Pre- and (right) post-mortem PET/CT scan of a mouse 16h after injection with a somatostatin receptor 2 (sst2) targeting peptide, DOTA-LM3, labeled with  $^{140}\text{Nd}$ . The white circle is drawn over the pancreas (sst2+) where the difference in the pre- and post-mortem pancreatic signal is due to rapid diffusion of  $^{140}\text{Nd}$ 's short-lived daughter nuclide,  $^{140}\text{Pr}$ , from the highly perfused pancreas into the blood stream. With further development, similar techniques with  $^{140}\text{Nd}$  may be used to determine the in vivo internalization status of labeled therapeutics.

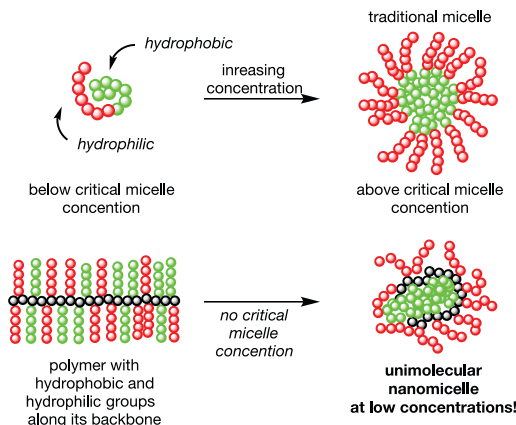
Our research ranges from developing metal-catalyzed reactions that act on organic and inorganic substrates, to designing polymers that interact in interesting ways with enzymes and drugs. The connecting theme is developing new chemistry and mentoring the next generation of scientists to tackle the challenge of sustainably meeting the needs of our species, which is predicted to number 9.5-13 billion people by the year 2100. We have several ongoing projects and frequently collaborate with scientists in academia and industry.

We have had long-standing interest in reactions of metal boryl complexes ( $M-BZ_2$ , where Z is an anionic substituent such as alkoxide) with organic molecules. Organoboron compounds are used extensively in pharmaceutical, agrochemical, and advanced materials industries. Consequently, new chemistry within this molecular class can eliminate steps and reduce waste streams associated with synthesis of these valuable intermediates. In this regard, we have developed new catalytic reactions, such as additions of B-B bonds to olefins and synthesis of B-C bonds from hydrocarbons and boranes, etc. The first thermal example of the latter catalytic reaction, now commonly referred to as C-H borylation, was discovered in our group. More recently, mechanistic studies integrating experimental and computational approaches have given us a deeper understanding of C-H borylation. The computational work is inspiring the design of new catalysts and boron reagents that are tailored to specific substrate classes.



#### The catalytic cycle for Iridium C-H borylation.

Our early polymer work focused on synthesis of biodegradable polymers with controllable properties. This evolved into the design of monomers with functional groups, which gave polymers that could readily be modified through chemical reactions. Recently, we have found that by incorporating combinations of hydrophobic and hydrophilic groups along the backbone, polymers that behave as nanomicelles can be prepared. Since the length of the initial polymer, and the sizes

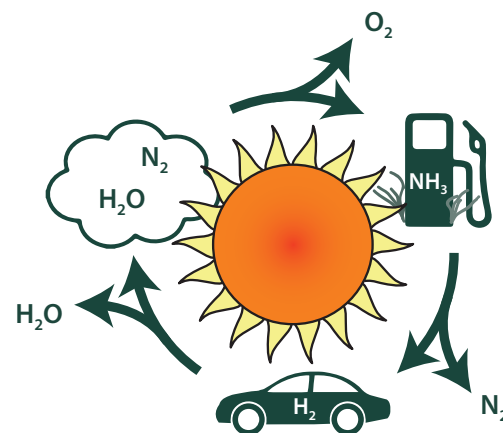


#### Design principles for controlling micelle size and assembly through polymer synthesis.

of hydrophilic and hydrophobic groups that are subsequently introduced, determine the sizes of the nanomicelles, we are exploring host-guest chemistry of these materials. For example, we have found that the nanomicelles can interact with enzymes to make them soluble in organic solvents with retention of enzymatic activity.

The newest project in our group explores the synthesis of ammonia and related nitrogen compounds using renewable energy. Ammonia synthesis via the Haber-Bosch process currently consumes approximately 2% of the energy we produce. The  $H_2$  that is required in the Haber-Bosch synthesis is produced by reacting methane or coal with water, which also generates large quantities of  $CO_2$ . Our goal is to develop new approaches for  $NH_3$  synthesis that can be coupled effectively to renewable energy sources like solar and wind, whose availability is intermittent.

The flip side of this project is that ammonia and other nitrogen compounds like hydrazine have been used as fuels. In fact, the X-15 aircraft that still holds speed and altitude records was fueled by  $NH_3$ . An example of a renewable nitrogen-based fuel cycle is shown below.



#### A cycle where nitrogen, water, and renewable energy could produce fuels with no $CO_2$ emissions.



**Milton R. (Mitch) Smith**

### Inorganic and Organic Chemistry for Sustainability in the 21<sup>st</sup> Century

PROFESSOR

B.S.,  
California Institute of Technology;

Ph.D.,  
Univ. of Chicago;

Postdoctoral Fellow,  
Univ. of California, Berkeley.



517-353-1071

#### SELECTED PUBLICATIONS

*Catalytic borylation of methane*, Smith, K. T.; Berritt, S.; González-Moreiras, M.; Ahn, S.; Smith, M. R., III; Baik, M.-H.; Mindiola, D. J., *Science* **2016**, 351, 1424-1427.

*Dextran functionalization enhances nanoparticle-mediated siRNA delivery and silencing*, Vocelle, D.; Chesniak, O. M.; Malefy, A. P.; Comiskey, G.; Adu-Berchie, K.; Smith, M. R., III; Chan, C.; Walton, S. P., *Technology* **2016**, 04, 42-54.

*Electrolysis of liquid ammonia for hydrogen generation*, Little, D. J.; Smith, M. R., III; Hamann, T. W., *Energy Environ. Sci.* **2015**, 8, 2775-2781.

*Reversible Borylene Formation from Ring-Opening of Pinacolborane and Other Intermediates Generated From 5-Coordinate Trisboryl Complexes: Implications for Catalytic C-H Borylation*, Ghaffari, B.; Vanchura, B. A., II; Chotana, G. A.; Staples, R. J.; Holmes, D.; Moleczka, R. E., Jr.; Smith, M. R., III, *Organometallics* **2015**, 34, 4732-4740.

*Harnessing C-H Borylation/Deborylation for Selective Deuteration, Synthesis of Boronate Esters, and Late Stage Functionalization*, Kallepalli, V. A.; Gore, K. A.; Shi, F.; Sanchez, L.; Chotana, G. A.; Miller, S. L.; Moleczka, R. E., Jr.; Smith, M. R., III, *J. Org. Chem.* **2015**, 80, 8341-8353.

*Silyl Phosphorus and Nitrogen Donor Chelates for Homogeneous Ortho Borylation Catalysis*, Ghaffari, B.; Preshlock, S. M.; Plattner, D. L.; Staples, R. J.; Maligres, P. E.; Krska, S. W.; Moleczka, R. E., Jr.; Smith, M. R., III, *J. Am. Chem. Soc.* **2014**, 136, 14345-14348.

*A Traceless Directing Group for C-H Borylation*, Preshlock, S. M.; Plattner, D. L.; Maligres, P. E.; Krska, S. W.; Moleczka, R. E., Jr.; Smith, M. R., III, *Angew. Chem., Int. Ed.* **2013**, 52, 12,915-12,919.

*"Clickable" polyglycolides: Tunable syntheses for thermoresponsive, degradable polymers*, Jiang, X.; Vogel, E. B.; Smith, M. R., III; Baker, G. L., *Macromolecules* **2008**, 41, 1937-1944.



## Ruth Waddell Smith Forensic Chemistry

PROFESSOR  
AND  
PROFESSOR / DIRECTOR  
FORENSIC SCIENCE PROGRAM  
SCHOOL OF CRIMINAL JUSTICE

B.S.  
Ph.D.  
Univ. of Strathclyde (Scotland).

517-353-5283



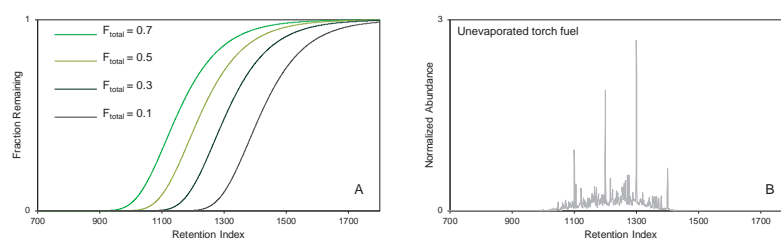
Research in our group focuses on improving current methods for the analysis, characterization, and identification of forensic evidence, while ensuring that such methods are directly implementable in forensic laboratories. Much of our research also includes application of multivariate statistical procedures for the association and discrimination of various types of forensic evidence. Our current main areas of interest are in developing a kinetic model to predict evaporation of ignitable liquids for fire debris applications and in developing a method to statistically compare mass spectral data for seized drug identification.

**Fire Debris Analysis** – Our research is focused on the development, refinement, and application of a model that can be used to generate the chromatogram corresponding to any

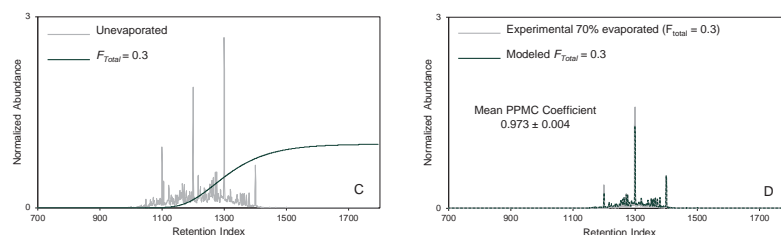
which is the most commonly identified liquid in fire debris samples, (2) demonstrating broader applicability of the model to predict evaporation of liquids of different chemical classes, and (3) in collaboration with Prof. Glen Jackson at West Virginia University, investigating the effect of elevated temperature on the predictive abilities of the model. This work is currently funded by the National Institute of Justice (Award No. 2018-DU-BX-0225).

**Controlled Substances** – Our work in this area is focused on developing tools to aid in the characterization and identification of novel psychoactive substances (NPS). We have developed a method for statistical comparison of mass spectra and are currently testing the method for the differentiation of positional isomers of ethylmethcathinone, fluormethamphetamine, and fentanyl analogs.

In this area, we are interested in determining the significance of discriminating ions based on fragmentation mechanisms. We have also demonstrated application of multivariate statistical models to classify various NPS according to structural subclass and are continuing this work to focus on fentanyl analogs. 🌱



Kinetic model used to generate fraction remaining ( $F_{Total}$ ) curves as function of retention index (A). Chromatogram of unevaporated liquid (B) collected and multiplied by  $F_{Total}$  curve (C) to generate predicted chromatogram (D), which is compared to chromatogram of experimentally evaporated liquid (D).



### SELECTED PUBLICATIONS

Improvements in a Kinetic-Based Model to Predict Evaporation of Gasoline, Eklund, N.K., Capistran, B.A., McGuffin, V.L., & Waddell Smith, *Forensic Chemistry* **2020**, 17, 100194.

Statistical Comparison of Mass Spectra of *Salvinorins* in *Salvia Divinorum* and Related *Salvia* Species, Bodnar Willard, M.A., Hurd, J.E., Waddell Smith, R., & McGuffin, V.L., *Forensic Chemistry* **2020**, 17, 100192.

Comparison of Variable Selection Methods prior to Linear Discriminant Analysis Classification of Synthetic Phenethylamines and Tryptamines, Setser, A.L. & Waddell Smith, R., *Forensic Chemistry* **2018**, 11, 77-86.

Fixed- and Variable-Temperature Models to Predict Evaporation of Petroleum Distillates for Fire Debris Applications, McLroy, J.W., Waddell Smith, R., & McGuffin, V.L., *Separations* **2018** 5(4), 47.

Characterization of 2C-Phenethylamines Using High-Resolution Mass Spectrometry and Kendrick Mass Defect Filters, Anstett, A., Chu, F., Alonso, D.E., & Waddell Smith, R., *Forensic Chemistry* **2018**, 7, 47-55.

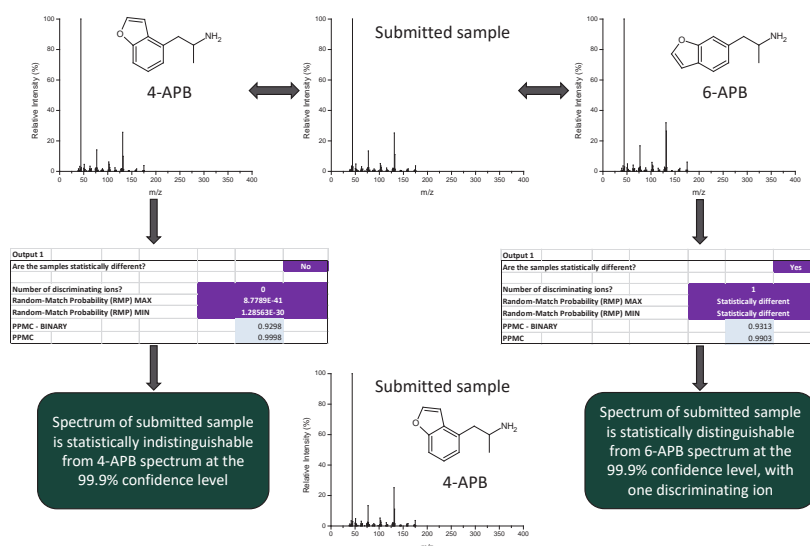
Statistical Comparison of Mass Spectra for Identification of Amphetamine-Type Stimulants, Bodnar-Willard, M.A., McGuffin, V.L., & Waddell Smith, R., *Forensic Sci. Int.* **2017**, 270, 111-120.

Mathematically Modeling Chromatograms of Evaporated Ignitable Liquids for Fire Debris Applications, Waddell Smith, R., Brehe, R.J., McLroy, J.W., McGuffin, V.L., *Forensic Chem.* **2016**, 2, 37-45.

evaporation level of an ignitable liquid. The model is based on first-order kinetics and is used to predict

evaporation rate constants of compounds as a function of retention index. These predicted chromatograms can then be used to populate reference collections eliminating the need to experimentally evaporate liquids. Current work focuses on (1) refining the model to improve prediction of more volatile compounds that are present in gasoline

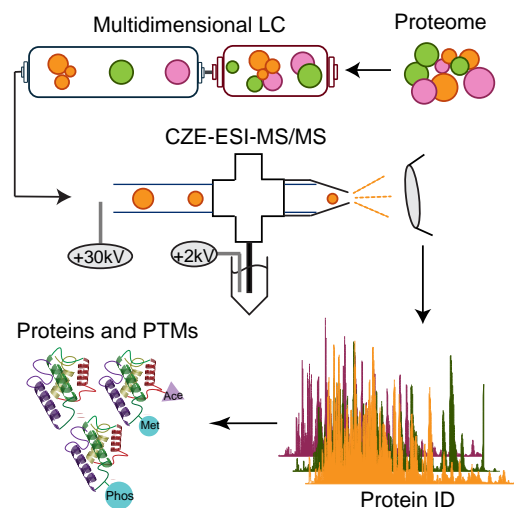
### Spectrum of submitted sample statistically compared to two reference spectra



**P**roteomics aims to comprehensively identify and quantify proteins in a biological system, including protein expression, localization, interaction, post-translational modifications (PTMs) and turnover. It routinely employs reversed-phase liquid chromatography (RPLC)-electrospray ionization (ESI)-tandem mass spectrometry (MS/MS) for protein identification. Capillary zone electrophoresis (CZE)-ESI-MS/MS has also attracted great attentions for proteomics due to its advantageous features. First, CZE-MS and RPLC-MS can produce complementary identifications and the combination of these two techniques can improve proteomic scale, and especially enhance proteoform identifications. Second, CZE can produce better intact protein separation than RPLC, benefiting top-down proteomics. Third, CZE-MS can yield higher sensitivity than RPLC-MS for detection of peptides and intact proteins. Fourth, CZE can separate proteins under native conditions. CZE-MS/MS will be an invaluable tool for native proteomics that aims to approach proteome-scale characterization of endogenous protein complexes in cells.

Our research focuses on development of novel analytical methodologies based on CZE-MS/MS for high-resolution, ultrasensitive and native proteomics, and applications of the new methodologies for answering important questions in biology.

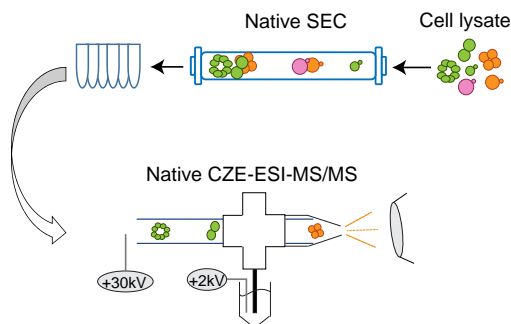
**(I)** Couple multi-dimensional LC to CZE-MS/MS for high-resolution and ultrasensitive proteomics. We employ orthogonal separation techniques to improve the separation of peptides and intact proteins in complex proteomes, boosting the proteome coverage from proteomics. We integrate microscale RPLC ( $\mu$ RPLC) with CZE-MS/MS to improve the sensitivity of proteomics, enabling deep proteomics of mass-limited samples. We collaborate with developmental biologists to apply our



**Multi-dimensional LC-CZE-MS/MS for high-resolution and ultrasensitive proteomics.**

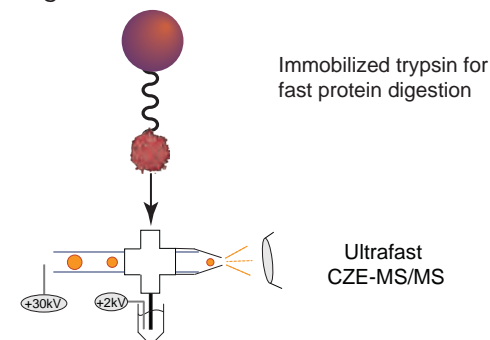
techniques for understanding important questions in vertebrate early embryogenesis using zebrafish as a model system. We are particularly interested in two important questions. First, how do proteins and/or their PTMs accurately control the zygotic genome activation at mid-blastula transition? Second, when and how do interblastomere differences arise during early cellular differentiation? We believe quantitative proteomics of zebrafish embryos and blastomeres across multiple developmental stages will provide valuable insight into those questions.

**(II)** Develop analytical methods for native proteomics. We couple size exclusion chromatography (SEC) to CZE-MS/MS for high-resolution separation of complex proteomes under native conditions. The SEC-CZE-MS/MS will enable large-scale identification and relative quantification of protein complexes directly from complex proteome samples and in discovery mode. We are particularly interested in characterization of protein-metal complexes in cells.

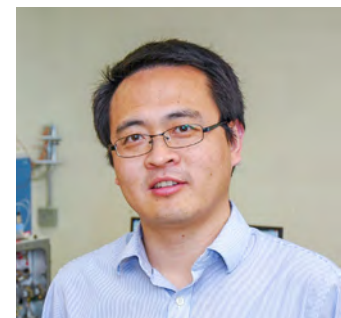


**SEC-CZE-MS/MS for native proteomics.**

**(III)** Couple magnetic beads-based immobilized trypsin to fast CZE-MS/MS for high-throughput proteomics. The state-of-the-art proteomics platforms require at least 12 hours for sample preparation, RPLC-MS/MS, and data analysis. The relatively low throughput impedes application of proteomics for daily and system-wide clinical diagnostics. Our goal is to improve the throughput of proteomics by over one order of magnitude, approaching half-an-hour proteomics. We believe the technique will facilitate daily and system-wide clinical diagnostics.



**Immobilized trypsin-CZE-MS/MS for high-throughput proteomics.**



**Liangliang Sun**

## High-resolution, Ultrasensitive, and Native Proteomics

**ASSOCIATE PROFESSOR**

B.S.,  
Dalian Univ. of Technology;  
Ph.D.,  
Dalian Institute of Chemical Physics,  
Chinese Academy of Sciences;  
Postdoctoral Fellow and  
Research Assistant Professor,  
Univ. of Notre Dame.



517-353-0498

### SELECTED PUBLICATIONS

*Single-Shot Top-Down Proteomics with Capillary Zone Electrophoresis-Tandem Mass Spectrometry for Identification of Nearly 600 Escherichia coli Proteoforms*, Lubeckyj, RA; McCool, EN; Shen, X; Kou, Q; Liu, X; Sun, L., *Anal. Chem.* **2017**, 89, 12059-12067.

*Native Proteomics in Discovery Mode Using Size-Exclusion Chromatography-Capillary Zone Electrophoresis-Tandem Mass Spectrometry*, Shen, X., Kou, Q., Guo, R., Yang, Z., Chen, D., Liu, X, Hong, H., Sun, L., *Anal. Chem.* **2018**, 90(17), 10095-10099.

*Deep Top-Down Proteomics Using Capillary Zone Electrophoresis-Tandem Mass Spectrometry: Identification of 5700 Proteoforms from the Escherichia coli Proteome*, McCool, EN; Lubeckyj, RA; Shen, X; Chen, D; Kou, Q; Liu, X; Sun, L; Chen, D., *Anal. Chem.* **2018**, 90, 5529-5533.

*Microscale Reversed-Phase Liquid Chromatography/Capillary Zone Electrophoresis-Tandem Mass Spectrometry for Deep and Highly Sensitive Bottom-Up Proteomics: Identification of 7500 Proteins with Five Micrograms of an MCF7 Proteome Digest*, Yang, Z, Shen, X., Chen, D., Sun L., *Anal. Chem.* **2018**, 90(17), 10479-10486.

*Capillary zone electrophoresis-tandem mass spectrometry for large-scale phosphoproteomics with the production of over 11000 phosphopeptides from the colon carcinoma HCT116 cell line*, Chen, D., Ludwig, K., Krokhin, O.V., Spicer, V., Yang, Z., Shen, X., Hummon, A.B., Sun, L., *Anal. Chem.* **2019**, 91(3), 2201-2208.



**Greg M. Swain**

## Electrochemistry, Carbon Material Science, Corrosion and Neuroanalytical Chemistry

**PROFESSOR**  
AND  
**MEMBER OF THE NEUROSCIENCE PROGRAM**

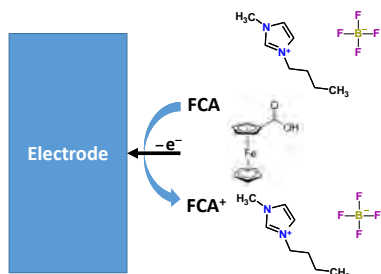
B.A., Univ. of Texas at Dallas;  
Ph.D., Univ. of Kansas;  
Postdoctoral Research Fellow, Space Power Institute and the Department of Chemical Engineering, Auburn Univ.;  
JSPS/NSF Postdoctoral Fellow, Tohoku Univ., Japan;  
Assistant Professor, Associate Professor, Utah State Univ.

517-353-1090



Research in our group is interdisciplinary and spans several fields: physical and analytical electrochemistry, carbon material science, point-of-care medical diagnostics, neuroanalytical chemistry, and corrosion of additively manufactured metal alloys. We conduct fundamental research to address key problems and technological needs in health and the environment. Our core science lies in the preparation, processing and application of multiple carbon materials including conducting diamond films and powders, nitrogen-incorporated tetrahedral amorphous carbon films, and screen- and inkjet-printed carbons.

**Electrochemical Reaction Kinetics and Mechanisms** - Factors controlling electron-transfer kinetics and mechanisms of soluble redox systems at boron-doped diamond and nitrogen-incorporated tetrahedral



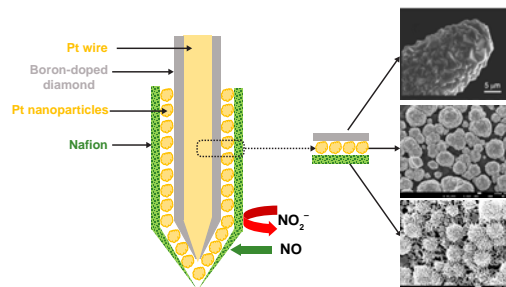
amorphous carbon thin-film electrodes are being investigated in aqueous, organic, and ionic liquid electrolytes. We seek to learn how factors such as the surface chemistry, electrode microstructure and doping level affect electrochemical reaction rate constants and mechanisms.

**Point-of-Care Medical Diagnostics** - The use of an electrochemical sensing platform for multiple potentially relevant biomarkers in collected exhaled breath condensate is a new paradigm in respiratory disease treatment and management. Modified screen- and inkjet-printed carbon electrodes are being

respiratory tract infections, which all are characterized by oxidative and nitrosative stress. Key markers targeted are pH, hydrogen peroxide, nitric oxide, and peroxynitrite.

We are also working on similar diagnostic technology for electrochemically monitoring biomarkers of wound healing and infection.

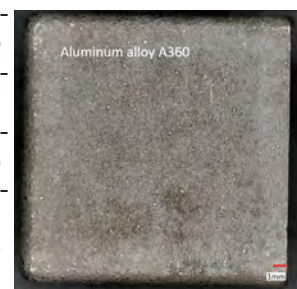
**Neuroanalytical Chemistry** - *In vitro* electrochemical methods, immunohistochemistry and other analytical tools are being used in collaborative research to better understand how potential



changes in neuromuscular signaling in the gastrointestinal tract are associated with pathological conditions in animal models of obesity and neurodegenerative disease. Molecules, such as serotonin, nitric oxide, ATP and acetylcholine, are being detected with diamond microelectrodes and microelectrode sensors.

**Additively Manufactured Metal Alloys and Coating Systems for Corrosion Control** -

Additive manufacturing (AM), or 3D printing, is the process of fabricating objects layer-by-layer, as opposed to traditional subtractive manufacturing technologies. We



### SELECTED PUBLICATIONS

*In Vitro Electrochemical Measurements of Serotonin Release in the Human Jejunum Mucosa Using a Diamond Microelectrode*, France, M; Galligan, JJ; Swain, GM., *Analyst* **2022**, in press.

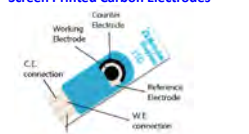
*Detection of Pyocyanin, with a Boron-Doped Diamond Electrode Using Flow Injection Analysis with Amperometric Detection and Square Wave Voltammetry*, Jarošová, R; Irikura, K; Rocha-Filho, RC; Swain, GM, *Electroanalysis* **2022**, 34. doi.org/10.1002/elan.202100562.

*Exhaled Breath Biomarker Sensing*, Vasilescu, A; Hrinchenko, B; Swain GM; Peteu, SF, *Biosens. Bioelectron.* **2021**, 182, 113193.

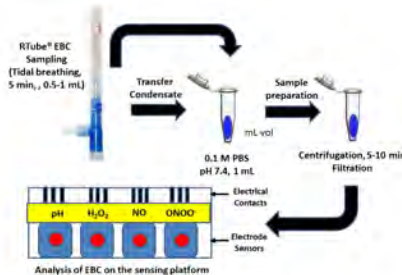
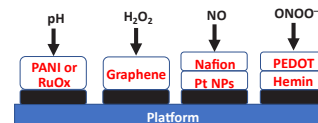
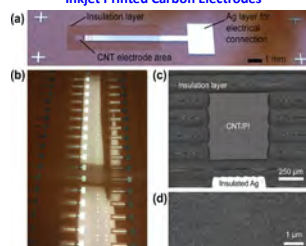
*Temperature Dependence of the Heterogeneous Electron-Transfer Rate Constant and Diffusion Coefficient for Ferrocene Carboxylic Acid in Room Temperature Ionic Liquids at Various Carbon Electrodes*, Jarošová, R; Bhardwaj, K; Swain, GM, *J. Electroanal. Chem.* **2020**, 167, 114744.

*Investigation of the Trivalent Chromium Process Conversion Coating as a Sealant for Anodized AA2024-T3*, Shruthi, TK; Walton, J; McFall-Boegeman, S; Westre, S; Swain, GM, *J. Electrochem. Soc.* **2020**, 167, 11504.

### Screen Printed Carbon Electrodes



### Inkjet Printed Carbon Electrodes



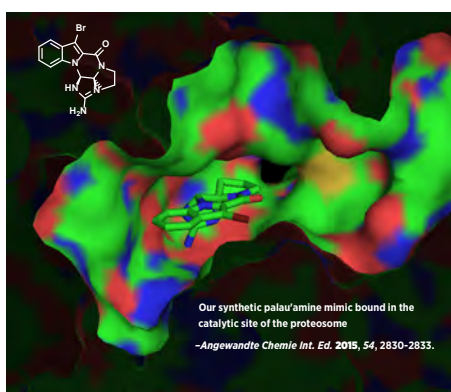
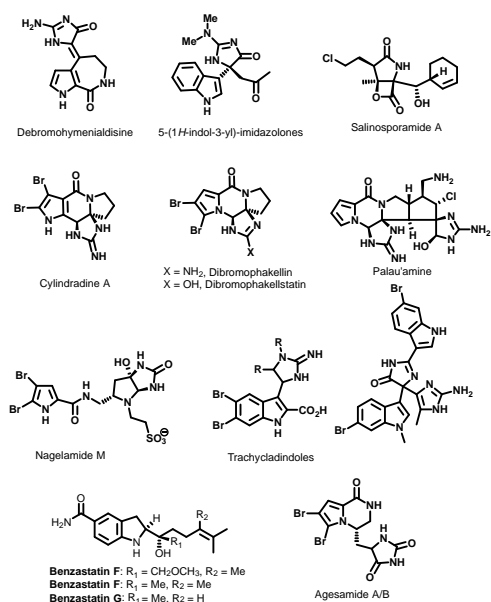
designed for use in diagnostic technology for the monitoring and care of patients with lung cancer, pneumonitis, COPD, obliterative bronchiolitis, cystic fibrosis, and general

seek to understand how the surface texture, alloy microstructure and elemental composition affect the electrochemical behavior of AM aluminum, steel, and titanium alloys prepared by laser powder-based sintering and fused filament fabrication methods. It is also of interest to learn how surface pretreatments and coating systems mitigate corrosion on these alloys.

Electrochemical methods, various microscopies and surface science tools are routinely used in these studies. 🌱

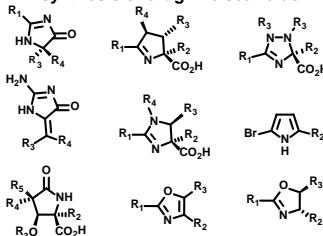
Our research program provides an interdisciplinary blend of synthetic and medicinal chemistry that includes the total synthesis of natural products, the discovery of new reactions, as well as the evaluation for their cellular mechanism and medicinal properties.

**Natural product synthesis** – Natural products are still the primary source for medicines, and marine sponge metabolites represent a highly diverse and complex class of natural products with remarkable biological activities. Members of our lab will develop new heterocyclic methodologies to efficiently access these natural products.<sup>1,4</sup> Cellular studies in our lab will subsequently be performed to identify the biological target responsible for the exciting biological properties these compounds elicit.<sup>2,6</sup>

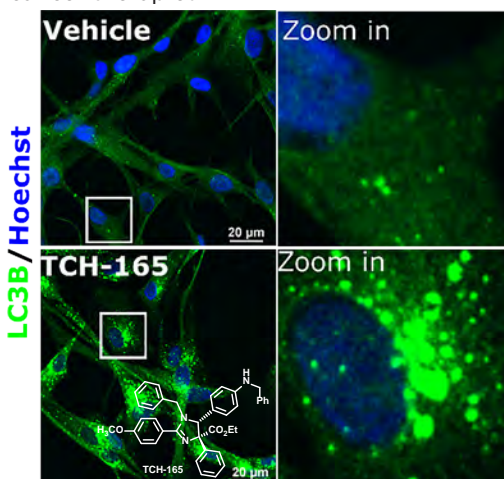


**Medicinal chemistry** – Our medicinal chemistry program is aimed at the development of more drug-like scaffolds containing a skeletal diversity inspired by natural products. One of our biological targets includes the human proteasome.

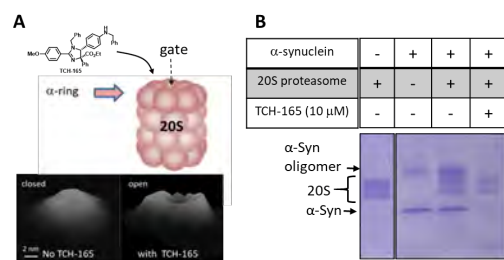
**Development of new reactions for the synthesis of drug-like scaffolds:**



**Cancer research** – Inhibition of the proteasome is clinically validated for the treatment of multiple myeloma, however nearly all patients relapse after some time. Our natural product-inspired scaffolds elicit a unique mechanism of inhibition of this large protease that overcomes resistance to current cancer therapies.<sup>3,8</sup>



**Alzheimer's and related research** – In Alzheimer's disease and related dementias, amyloid oligomers inhibit the activity of the proteasome, resulting in the accumulation, oligomerization and aggregation of disordered proteins such as A $\beta$ , tau and  $\alpha$ -synuclein.<sup>2,5,6</sup> Our research team is exploring the use of small heterocyclic scaffolds to activate a specific sub-complex of the proteasome, the 20S proteasome, to treat these neurodegenerative diseases.<sup>7</sup>



**TCH-165 opens the gate of the 20S proteasome and enhances  $\alpha$ -synuclein degradation.** A. AFM images of 20S  $\alpha$ -ring showing TCH-165 opening the gate of the 20S, rendering an activated 20S proteasome. B. Coomassie stain of TCH-165 enhanced degradation of  $\alpha$ -syn (and oligomers) by the 20S in vitro.



**Jetze J. Tepe**  
**Synthetic and Medicinal Chemistry**

PROFESSOR

B.S.,  
 Jacksonville Univ.;  
 Ph.D.,  
 Univ. of Virginia;  
 Postdoctoral Research,  
 Colorado State Univ.



517-353-0497

SELECTED PUBLICATIONS

1. *One-Pot Friedel-Crafts/Robinson-Gabriel Synthesis of the Indole-Oxazole Scaffold and its Application to the Synthesis of Breitfussins C, G, and H*, Savelson, Evan; Tepe, Jetze J., *J. Org. Chem.* **2022**, in print, <https://doi.org/10.1021/acs.joc.2c00033>.
2. *Design, Synthesis and Biological Evaluation of Potent 20S Proteasome Activators for Treatment of Neurodegenerative Diseases*, Staerz, S. D.; Jones, C. L. and Tepe, Jetze J., *J. Med. Chem.* **2022**, *65*, 6631–6642. <https://doi.org/10.1021/acs.jmedchem.1c02158>
3. *Small Molecule 20S Proteasome Enhancer Regulates MYC Protein Stability and Exhibits Antitumor Activity in Multiple Myeloma*, Njomen, Evert; Vanecek, Allison; et al., *Biomedicines* **2022**, *10*, 938. <https://doi.org/10.3390/biomedicines10050938>
4. *Total Synthesis of Nortopentin D via a Late-Stage Pinacol-Like Rearrangement*, Keel, Katarina L.; and Tepe, Jetze J., *Organic Lett.* **2021**, *23*, 5368–5372. <https://doi.org/10.1021/acs.orglett.1c01681>
5. *Fluspirilene analogs activate the 20S proteasome and overcome proteasome impairment by intrinsically disorder protein oligomers*, Fiolek, Taylor J.; Keel, Katarina L. and Tepe, Jetze J., *ACS Chem. Neurosci.* **2021**, *12*, 1438–1448.
6. *Dihydroquinazolines enhance 20S proteasome activity and induce degradation of alpha-synuclein, an intrinsically disordered protein associated with neurodegeneration*, Fiolek, Taylor J.; Magyar, Christina L.; Wall, Tyler J.; Davies, Steven B.; Campbell, Molly V.; Savich Christopher J.; Tepe, Jetze J. and Mosey, R. Adam, *Bioorg. and Med. Chem. Lett.* **2021**, *36*, 127821.
7. *Advances in Proteasome Enhancement by Small Molecules*, George, D. E. and Tepe, Jetze J., *Biomolecules* **2021**, *11*, 1789.
8. *Regulation of Autophagic Flux by the 20S proteasome*, Njomen, E. and Tepe, J., *Cell, Chemical Biology*, **2019**, *26*, 1283–1294.



**Kevin Walker**

## Functional Analysis of Enzymes on Biosynthetic Pathways of Plant-derived Bioactive Compounds

ASSOCIATE PROFESSOR OF CHEMISTRY

AND

BIOCHEMISTRY & MOLECULAR BIOLOGY

B.S.,  
Univ. of Washington;  
Research Chemist,  
FDA (Bothell,WA);

Ph.D.,  
Univ. of Washington;  
NIH Postdoc. Research Fellow,  
Research Assistant Professor,  
Institute of Biological Chemistry,  
Washington State Univ.

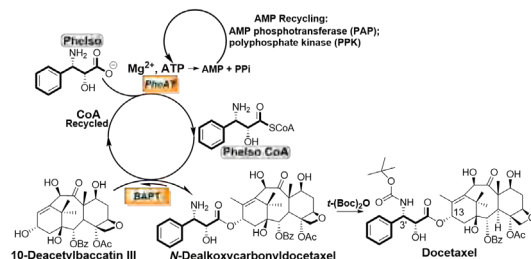
517-353-1122



We use interdisciplinary methods to evaluate enzyme catalysts from various sources, such as bacteria, plants, and yeast, with non-natural substrates. Our vision is to transform natural compounds or synthetically-derived chemicals to novel products. Transfer of the wild-type or saturation mutants of genes encoding these enzymes into a chassis organism can potentially make various bioactive molecules *in vivo* or *in vitro*.

**Biocatalysis of Docetaxel** – Docetaxel is used for various cancers, and for stent implants in heart surgery. Current methods to make docetaxel still use an 11 to 12-step semisynthesis, which involves protecting group chemistry that compromises yields and reduces atom economy.

We use regioselective biocatalysts (*Taxus* Acyltransferases (AT) and Bacterial CoA Ligases) to bypass protecting group chemistry to make docetaxel.

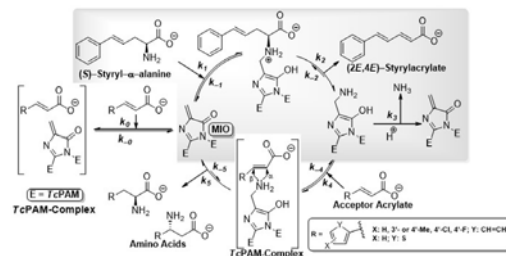


**Coupling acyltransferases with CoA ligases (above) provides a Green source of docetaxel and its drug analogues.**

**Paclitaxel (Taxol) Pathway Aminomutase** – A *Taxus* phenylalanine aminomutase (TcPAM) converts (2S)- $\alpha$ -phenylalanine ((2S)- $\alpha$ -Phe) to (3R)- $\beta$ -Phe and lies on the paclitaxel (Taxol™) biosynthetic pathway in *Taxus* plants.

To understand how to use TcPAM chemistry to biocatalyze  $\beta$ -amino acids, it is necessary to understand the subtleties of its mechanism.

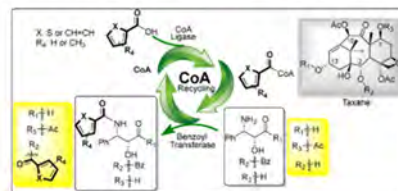
We used stopped-flow monitoring of product release to measure the exponential burst phase of TcPAM at presteady state.



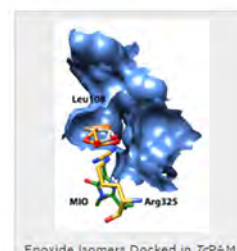
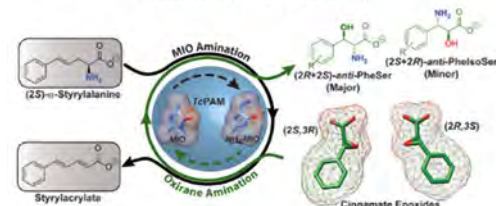
A new graduate student can embark on studies involving organic chemistry synthesis of novel surrogate substrates. Other areas of training include molecular cloning

techniques, expression of various enzymes in *E. coli*, and assay development. Included are basic biochemical applications and molecular engineering approaches related to enzyme kinetics, enzyme purification and characterization, and various analytical techniques (such as NMR, GC/MS, LC-MS/MS), and X-ray crystallography).

## Recycling CoA in the Biocatalysis of Surrogate Taxanes to Access New Generation Bioactive Compounds



## Biocatalysis of Arylserines and Arylisoserines from Epoxides by an MIO $\alpha/\beta$ -Aminomutase and a Mild Amine-Group Donor (more here)



### SELECTED PUBLICATIONS

CoA Recycling by a Benzoate Coenzyme A Ligase in Cascade Reactions with Aroyltransferases to Biocatalyze Paclitaxel Analogs, S.A. Sullivan ; I.N. Nawarathne; K.D. Walker, *Arch. Biochem. Biophys.* **2020**, (in press). DOI: 10.1016/j.abb.2020.108276

Exploring the Scope of an  $\alpha/\beta$ -Aminomutase for the Amination of Cinnamate Epoxides to Arylserines and Arylisoserines, P.K. Shee; N.D. Ratnayake; T. Walter; O. Goethe; E.N. Onyeozili; K.D. Walker, *ACS Catal.* **2019**, *9*, 7418-7430. DOI: 10.1021/acscatal.9b01557

Understanding Which Residues of the Active Site and Loop Structure of a Tyrosine Aminomutase Define its Mutase and Lyase Activities, G. Attanayake; T. Walter; K. D. Walker, *Biochemistry (ACS)*, **2018**, DOI: 10.1021/acs.biochem.8b00269.

Biocatalysis of a Paclitaxel Analogue: Conversion of Baicatin III to N-Debenzoyl-N-(2-furoyl)paclitaxel and Characterization of an Amino Phenylpropanoyl CoA Transferase, C.K. Thornburg; T. Walter; K.D. Walker, *Biochemistry (ACS)* **2017**, *56* (44), 5920-5930.

Paclitaxel Biosynthesis: Adenylation and Thiolation Domains of an NRPS TycA PheAT Module Produce Various Arylisoserine CoA Thioesters, R. Muchiri; K.D. Walker, *Biochemistry (ACS)* **2017**, *56* (10), 1415-1425.



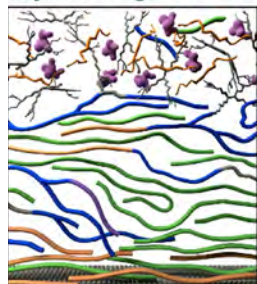
**Analysis of biomolecules in plant biomass, fungi, and algae** – Carbohydrates are essential to the life processes of living organisms but their structures are under-investigated relative to nucleic acids and proteins. We aim to establish an atomic-level toolbox, based on solid-state NMR (ssNMR), to assess the structure of carbohydrates and associated molecules (proteins, lipids, lignin, etc.) using intact and often alive cells. The insights will guide the engineering of plants and algae for energy, and the design of better drugs against microbial infections.



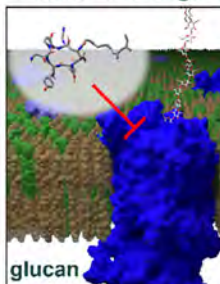
Cellular ssNMR

**Biomedical: carbohydrate armor of fungi** – Invasive fungal infections (to kidneys, lungs, etc.) occur to two million patients each year, with high mortality (20-95%). Fungal cell walls are promising targets for novel antifungal drugs. We are establishing molecular-level structural models of the cell walls of *Aspergillus*, *Candida* and *Rhizopus* (a mold causing coinfections during COVID-19) by mapping out the mobility, hydration, and packing of carbohydrates and proteins in living cells. We identify a rigid and hydrophobic core of chitin and  $\alpha$ -glucan, which is embedded in a soft glucan matrix and capped by a shell of protein and mannan. We are also examining how fungi remodel the cell wall to handle antifungal drugs.

Layered fungal cell wall



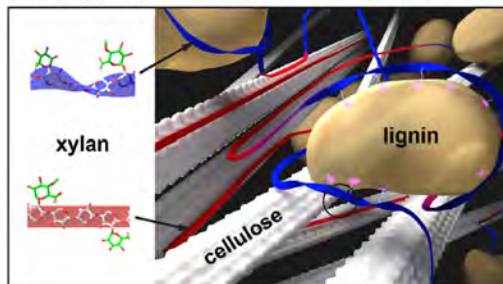
Effect of antifungal c



**Bioenergy: carbohydrate-lignin interface in plant biomass** – Carbohydrate-lignin interactions hamper the biochemical and enzymatic processing required to produce biofuel. We are determining how the conformation of carbohydrates and the structure of lignin directly regulate their physical packing in intact stems of grass (maize), hardwood (poplar) and softwood (spruce). We reveal that xylan uses its flat-ribbon conformers to coat the surface of

cellulose microfibrils and uses its twisted conformers to link lignin nanodomains. Such findings provide the structural basis for optimizing biofuel production.

Carbohydrate-aromatic interface in plant biomass



**Biopolymer: the understudied algae** – As the basis of aquatic food chain, microalgae play crucial roles in pharmaceutical and nutraceutical industries. We are elucidating the structure of starch grains, cell walls, glycoproteins, and glycolipids in multiple algal species, such as *Chlamydomonas* and *Chlorella*, to correlate biomolecular structure with digestibility in these microalgae.



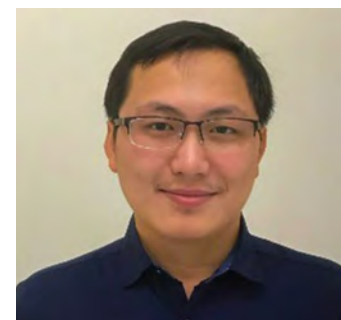
Algal carbohydrates

**Method: label-free NMR and database** – NMR analysis typically requires isotope-labeling, which is impractical for large biosystems and biomedical materials that cannot be replicated in vitro. We are thus developing sensitivity-enhancing Dynamic Nuclear Polarization (DNP) method to enable high-resolution analysis of unlabeled materials. Coupling DNP with a carbohydrate NMR database coded in my lab, we can rapidly screen the structure of molecules in microbes, photosynthetic systems, and later, human cells.



Carbohydrate structure by DNP and CryoEM

**Protein structure and dynamics** – As collaborative efforts, we are elucidating the interplay of antimicrobial peptides with phospholipid membranes, and determining metal binding in catalytic amyloid fibrils. ☘



Tuo Wang

## Structural Analysis of Biomolecules and Biomaterials by Solid-State NMR

ASSOCIATE PROFESSOR

B.S.,  
Nankai Univ.;  
Ph.D.,  
Massachusetts Inst. of Technology;  
Postdoctoral Fellow,  
Massachusetts Inst. of Technology.



517-355-9715

### SELECTED PUBLICATIONS

*Carbohydrate-aromatic interface and molecular architecture of lignocellulose*, Kirui...Wang, *Nat. Commun.* **2022**, *13*, 538. **Editor's highlight.**

*Solid-state NMR investigations of extracellular matrices and cell walls of algae, bacteria, fungi, and plants*, Ghassemi...Wang, *Chem Rev.* **2022**, in press. **Supplementary Cover.**

*A molecular vision of fungal cell wall organization by functional genomics and solid-state NMR*, Chakraborty...Wang, *Nat. Commun.* **2021**, *12*, 6346.

*Identification and quantification of glycans in whole cells: architecture of microalgal polysaccharides described by solid-state NMR*, Poulhazan ... Wang, *J. Am. Chem. Soc.* **2021**, *143*, 46, 19374-388. **Front Cover.**

*Lignin-polysaccharide interactions in plant secondary cell walls revealed by solid-state NMR*, Kang...Wang, *Nat. Commun.* **2019**, *10*, 347.

*Molecular architecture of fungal cell walls revealed by solid-state NMR*, Kang...Wang, *Nat. Commun.* **2018**, *9*, 2747.



**Timothy H. Warren**

## Synthetic Inorganic Chemistry for Catalysis and Biology

**ROSENBERG PROFESSOR AND CHAIRPERSON**

B.S.,  
Univ. of Illinois at Urbana-Champaign;  
Ph.D.,  
Massachusetts Inst. of Technology;  
Postdoctoral Fellow,  
Univ. of Münster  
Professor,  
Georgetown Univ.

517-353-1086



### SELECTED PUBLICATIONS

*A Three Coordinate Copper(II) Alkynyl Complex in C-C Bond Formation: The Sesquicentennial of the Glaser Coupling*, Bakhoda, A.; Okoromoba, O.; Greene, C.; Boroujeni, M. R.; Bertke, J. A.; Warren, T. H., *J. Am. Chem. Soc.* **2020**, *142*, 18483-18490.

*Lewis Acid Coordination Redirects S-Nitrosothiol Signaling Output*, Hosseininasab, V.; McQuilken, A. C.; Bakhoda, A.; Bertke, J. A.; Timerghazin, Q. K.; Warren, T. H., *Angew. Chem. Int. Ed.* **2020**, *59*, 10854-10858. Noted as a *Very Important Paper*.

*Tris(pyrazolyl)borate Copper Hydroxide Complexes Featuring Tunable Intramolecular H-bonding*, Gardner, E. J.; Cobb, C. R.; Bertke, J. A.; Warren, T. H., *Inorg. Chem.* **2019**, *58*, 11248-11255.

*Copper-Catalyzed C(sp<sup>3</sup>)-H Amidation: Sterically Driven Primary and Secondary C-H Site-Selectivity*, Bakhoda, A.; Jiang, Q.; Bertke, J. A.; Cundari, T. R.; Warren, T. H., *Angew. Chem. Int. Ed.* **2019**, *58*, 3421-3425.

*Nitrosyl Linkage Isomers: NO Coupling to N<sub>2</sub>O at a Mononuclear Site*, Kundu, S.; Phu, P. N.; Ghosh, P.; Kozimor, S. A.; Bertke, J. A.; Stieber, S. C. E.; Warren, T. H., *J. Am. Chem. Soc.* **2019**, *141*, 1415-1419.

*Copper(II) Activation of Nitrite: Nitrosation of Nucleophiles and Generation of NO by Thiols*, Kundu, S.; Kim, W. Y.; Bertke, J. A.; Warren, T. H., *J. Am. Chem. Soc.* **2017**, *139*, 1045-1048. Highlighted as a *JACS Spotlight*: "Nitric Oxide on a New Route"

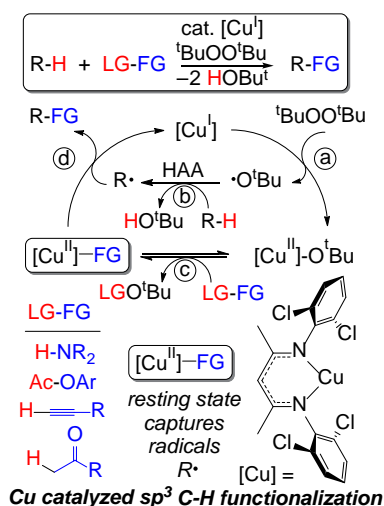
*Copper Catalyzed sp<sup>3</sup> C-H Etherification with Acyl Protected Phenols*, Salvador, T. K.; Arnett, C. H.; Kundu, S.; Sapiezynski, N. G.; Bertke, J. A.; Boroujeni, M. R.; Warren, T. H., *J. Am. Chem. Soc.*, **2016**, *138*, 16580-16583.

*A Motif for Reversible Nitric Oxide Interactions in Metalloenzymes*, Zhang, S.; Melzer, M. M.; Nermin Sen, S.; Celebi-Olcum, N.; Warren, T. H., *Nature Chem.* **2016**, *8*, 663-669.

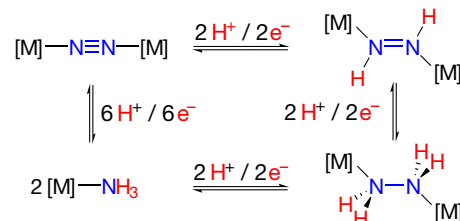
We develop environmentally friendly new methods for organic synthesis through ubiquitous C-H bonds, explore the interconversion of nitrogen and ammonia as carbon-free fuels, and decode ways that biology communicates using nitric oxide as a molecular messenger. Our laboratory studies how chemical reactions work that are catalyzed by metal ions such as iron, copper, and zinc to better enable new insights into the development of useful catalysts for synthesis and energy applications as well as to lay the groundwork for therapeutic interventions connected with nitric oxide misregulation.

Guided and enabled by synthetic inorganic chemistry, we seek to understand key intermediates that control C-H functionalization, ammonia/nitrogen interconversion, and bioinorganic nitric oxide processing. We employ a diverse range of synthesis and characterization techniques to reveal insights into chemical structure and reactivity. Beyond more traditional inorganic and organic synthesis techniques, students regularly perform X-ray crystallography, EPR spectroscopy, low temperature UV-vis spectroscopy, and DFT calculations. We also collaborate extensively with scientists from other institutions to study new molecules we make by resonance Raman spectroscopy as well as X-ray absorption and emission spectroscopy.

**C-H Functionalization** - Through mechanistic understanding of reactive copper intermediates, we develop new reactions to directly convert sp<sup>3</sup> C-H to C-C, C-N, C-O, and C-S bonds. These methods offer unique synthetic opportunities for the late stage functionalization of organic molecules. A key aspect of our approach involves the rational design of low coordinate copper(II) complexes [Cu(II)]-FG such as amides, phenoxides, aryls, and acetylides that efficiently capture carbon based radicals R• to provide functionalized products R-FG.



**Ammonia - A Carbon-Free Fuel** - Ammonia is a carbon-free fuel produced on a scale of over 150 M tons / year. We examine the fundamental chemistry of N-H and N-N bond cleavage and formation to enable the development molecular electrocatalysts based on iron and copper to cleanly generate energy from NH<sub>3</sub> and ultimately, to sustainably produce NH<sub>3</sub> from N<sub>2</sub>. Using specially designed molecular scaffolds, we examine H-bonding to metal bound diazene (N<sub>2</sub>H<sub>2</sub>) ligands in metal complexes [M]-N<sub>2</sub>H<sub>2</sub>-[M] to uncover low barrier pathways for N-H bond formation and cleavage. Mechanistically considering pathways for N-H cleavage and N-N bond formation, we have also developed families of iron and copper based molecular electrocatalysts for ammonia oxidation.

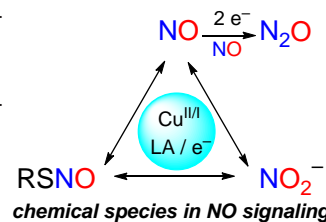


**interconversion of N<sub>2</sub> and NH<sub>3</sub> via 2 H<sup>+</sup>/2 e<sup>-</sup> steps**

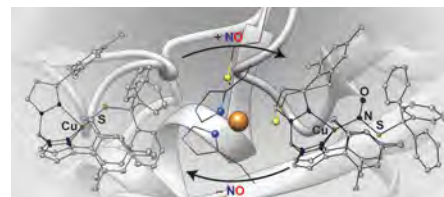


**electrochemical oxidation of ammonia**

**Modeling NO Signaling Chemistry** - Nitric oxide (NO) is a powerful signaling molecule with far reaching effects. Inspired by Cu and Zn environments in biology, we employ synthetic models that outline pathways to interconvert molecules in NO signaling such as nitrate, nitrite, and S-nitrosothiols (RSNO).



For instance, a copper(II) thiolate [Cu(II)]-SR that serves as a model for a type 1 copper electron transfer site reversibly binds NO by insertion into the Cu-S bond to give the corresponding copper(I) S-nitrosothiol adduct [Cu(I)](RSNO). Not only does this pathway interconnect NO and S-nitrosothiol signals, but the inability of the copper(I) S-nitrosothiol adduct to undergo reduction reveals that NO binding to the copper(II) thiolate serves as a reversible switch that controls electron-transfer. 🌱



We are a biophysical chemistry group that is focused on understanding the mechanism of entry by viruses enveloped by a membrane. Many important human pathogens are enveloped viruses, including Human Immunodeficiency (HIV), Influenza, Measles, Rabies, West Nile, Zika, Ebola, SARS, and MERS. Each virus has evolved a protein in its membrane that catalyzes the joining (“fusion”) of the virus membrane with the membrane of the target cell. We are studying the glycoprotein 41 kDa (gp41) fusion protein of HIV and

circular dichroism spectroscopy, fluorescence spectroscopy, hydrogen-deuterium exchange mass spectrometry, X-ray crystallography, and electron microscopy. We also have a significant effort in protein synthesis and chromatographic purification that includes molecular biology and protein expression in bacteria, solid-phase peptide synthesis, and native chemical ligation. A side-project in the laboratory is NMR analysis of expressed proteins in bacterial inclusion bodies, which are commonly-formed solid protein aggregates. We want to understand why these



**David P. Weliky**

## Biophysical Chemistry and Nuclear Magnetic Resonance

**PROFESSOR**

B.A.,  
Swarthmore College;  
Ph.D.,  
Univ. of Chicago;  
Postdoctoral Fellow,  
National Institutes of Health.



517-353-1177

### SELECTED PUBLICATIONS

*Rapid  $^2\text{H}$  NMR Transverse Relaxation of Perdeuterated Lipid Acyl Chains of Membrane with Bound Viral Fusion Peptide Supports Large-Amplitude Motions of These Chains That Can Catalyze Membrane Fusion*, U. Ghosh and D. P. Weliky, *Biochemistry* **2021**, 60, 2637-2651.

*$^2\text{H}$  Nuclear Magnetic Resonance Spectroscopy Supports Larger Amplitude Fast Motion and Interference with Lipid Chain Ordering for Membrane that Contains  $\beta$  Sheet Human Immunodeficiency Virus gp41 Fusion Peptide or Helical Hairpin Influenza Virus Hemagglutinin Fusion Peptide at Fusogenic pH*, U. Ghosh and D. P. Weliky, *Biochim. Biophys. Acta* **2020**, 1862, 183404.

*Hydrogen-Deuterium Exchange Supports Independent Membrane-Interfacial Fusion Peptide and Transmembrane Domains in Subunit 2 of Influenza Virus Hemagglutinin Protein, a Structured and Aqueous-Protected Connection between the Fusion Peptide and Soluble Ectodomain, and the Importance of Membrane Apposition by the Trimer-of-Hairpins Structure*, A. Ranaweera, P. U. Ratnayake, E. A. P. Ekanayaka, R. Declercq, and D. P. Weliky, *Biochemistry* **2019**, 58, 2432-2466.

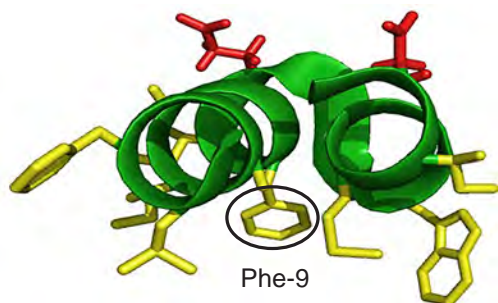
*The Stabilities of the Soluble Ectodomain and Fusion Peptide Hairpins of the Influenza Virus Hemagglutinin Subunit II Protein Are Positively Correlated with Membrane Fusion*, A. Ranaweera, P. U. Ratnayake, and D. P. Weliky, *Biochemistry* **2018**, 57, 5480-5493.

*Efficient Fusion at Neutral pH by Human Immunodeficiency Virus gp41 Trimers Containing the Fusion Peptide and Transmembrane Domains*, S. Liang, P. U. Ratnayake, C. Keinath, L. Jia, R. Wolfe, A. Ranaweera, and D. P. Weliky, *Biochemistry* **2018**, 57, 1219-1235.

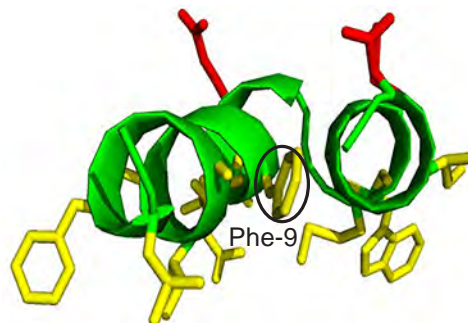
*Closed and Semiclosed Interhelical Structures in Membrane vs Closed and Open Structures in Detergent for the Influenza Virus Hemagglutinin Fusion Peptide and Correlation of Hydrophobic Surface Area with Fusion Catalysis*, U. Ghosh, L. Xie, L. Jia, S. Liang, and D. P. Weliky, *J. Am. Chem. Soc.* **2015**, 137, 7548-7551.

*REDOR Solid-State NMR as a Probe of the Membrane Locations of Membrane-Associated Peptides and Proteins*, L. Jia, S. Liang, K. Sackett, L. Xie, U. Ghosh, and D. P. Weliky, *J. Mag. Res.* **2015**, 253, 154-165.

### Closed structure



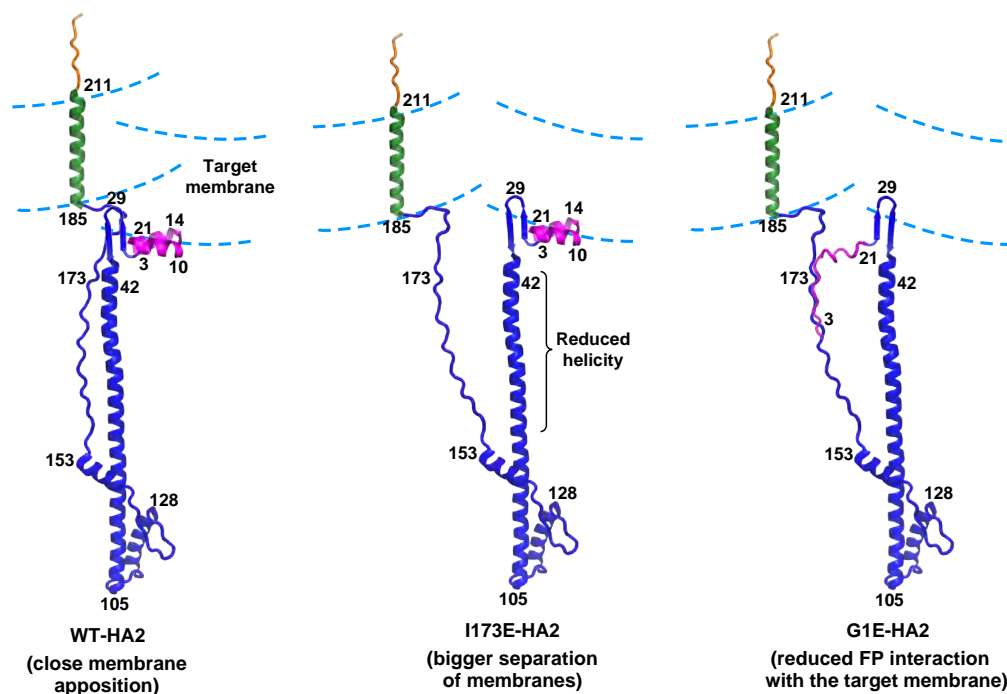
### Semi-closed structure



*Structures of the influenza virus HA2 fusion peptide in membrane deduced from our NMR data.*

hemagglutinin subunit 2 (HA2) fusion protein of influenza. Our work and contributions include the protein structures and locations in membrane. We also study the changes in membrane structure associated with the protein. A significant fraction of our effort is in development and application of “solid-state”, i.e. anisotropic nuclear magnetic resonance (NMR) to these proteins. We also apply a variety of other biophysical methods including

aggregates form, and the degree of folding of individual proteins within the aggregates. Our NMR methodology focuses on quantitative determination of distributions of populations of protein structures and membrane locations, with a particular emphasis on the rotational-echo double-resonance (REDOR) approach which is robust and amenable to quantitative analysis. 🌱



*Models for influenza HA2-mediated membrane apposition based on our experimental data.*



## Angela K. Wilson

### Physical, Theoretical, and Computational Chemistry

JOHN A. HANNAH  
DISTINGUISHED PROFESSOR

AND

ASSOCIATE DEAN FOR  
STRATEGIC INITIATIVES

AND

PRESIDENT, 2022,  
AMERICAN CHEMICAL SOCIETY

B.S.,  
Eastern Washington Univ.;

Ph.D.,  
Univ. of Minnesota;

DOE/AWU Postdoctoral Fellow.

517-353-1111



#### SELECTED PUBLICATIONS

*Ab Initio Approaches for Heavy Element Energetics: Ionization Potentials for the Actinide Series of Elements*, S.C. North and A.K. Wilson, *J. Phys. Chem.* **2022**, DOI: 10.1021/acs.jpca.2c01007.

*Super-ccCA (s-ccCA): An Approach for Accurate Transition Metal Chemistry*, B.K. Welch, N.M.S. Almeida, and A.K. Wilson, *Mol. Phys.* **2021**, DOI: 10.1080/00268976.2021.1963001.

*Adsorption, Structure, and Dynamics of Short- and Long-Chain PFAS Molecules in Kaolinite: Molecular Level Insights*, Loganathan and A.K. Wilson, *Env. Sci. Tech.* **2022**, DOI: 10.1021/acs.est.2c01054.

*Machine Learning, Artificial Intelligence, and Chemistry: How Smart Algorithms are Reshaping Simulation and the Laboratory*, D. Kuntz and A.K. Wilson, *Pure Appl. Chem.* **2022** (in press).

*Multi-configuration Electron-nuclear Dynamics: An Open-shell Approach*, C. Wang, I.S. Ulusoy, L.E. Aebersold, and A.K. Wilson, *J. Chem. Phys.* **2021**, 155, 154103.

*Electronic-nuclear Quantum Dynamics of Diatomic Molecules: Nonadiabatic Signatures in Molecular Spectra*, L. Aeberold, I.S. Ulusoy, and A.K. Wilson, *Mol. Phys.* **2021**, e1988743.

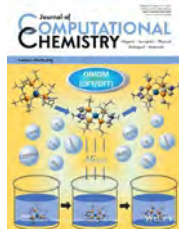
*Considering Density Functional Approaches for Actinide Species: The An66 Molecule Sets*, L.E. Aebersold and A.K. Wilson, *J. Phys. Chem. A*, **2021**, 125, 7029-7035.

*Binding of Per- and Polyfluoro-alkyl Substances (PFASs) to Peroxisome Proliferator-activated Receptor Gamma (PPAR $\gamma$ )*, N.M.S. Almeida, Y. Eken, and A.K. Wilson, *ACS Omega* **2021**, 6, 15103-15114.

*Multireference Calculations on the Ground and Lowest Excited States and Dissociation Energy of LuF*, N.M.S. Almeida, T.R.L. Melin, and A.K. Wilson, *J. Chem. Phys.* **2021**, 154, 244304.

The research in our group focuses upon the development and understanding of computational methodologies, and studies in transition metals and heavy element chemistry, catalysis, protein modeling, drug design/understanding of disease, environmental/green chemistry, and many other areas. One of the great features of theoretical and computational chemistry is that they can be utilized to investigate a broad array of challenges, and our group is engaged in areas including quantum mechanical and quantum dynamical method development, thermochemical and spectroscopic studies of small molecules, protein modeling and drug design, catalysis design, environmental challenges (i.e., CO<sub>2</sub>, PFAS), heavy element and transition metal chemistry, and mechanical properties of materials.

**Development and understanding of methodologies** – Much of our group's efforts are focused upon the development of ab initio approaches that aim for accurate prediction of thermochemical properties across the periodic table. Included in our efforts has been the development of successful and versatile

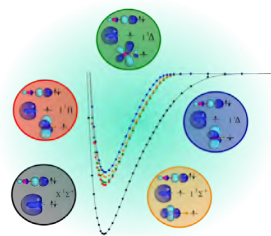


*This paper focused upon design strategies for the prediction of pKa of transition metal species.* (From *J. Comp. Chem.* **2020**, *41*, 171, cover article.)

ab initio composite schemes, called correlation consistent Composite Approaches (ccCA), that provide reduced computational cost (in terms of computer time, memory, and disk space) means to achieve energetic predictions. The approaches are useful for ground-state, excited-state, and transition-state energies, and can be applied to situations where single-reference wavefunctions or where multireference wavefunctions (i.e., bond-breaking, diradicals) are necessary. Included in our work is the development of Gaussian basis sets, providing new additions to the correlation consistent basis set family, and rigorous evaluation of existing and new basis sets. Another area of interest is in gauging the performance of methodologies, such as density functional theory, particularly for situations where there may be few, if any, needed experiments for comparison. Efforts extend across the periodic table, with substantial focus upon the transition metals.

**Heavy element chemistry** – The complexity of the heavy elements results in their great utility in applications from cell phones to stealth technology. We are developing a better understanding of the fundamental properties of heavy element species, as well

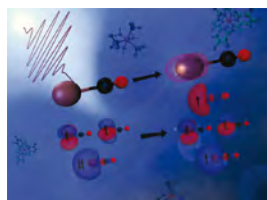
as the methodologies needed to describe their energetic and spectroscopic properties, and



*An analysis of the ground and excited state potential energy channels for LuF.* (*J. Chem. Phys.* **2021**.)

utilizing this knowledge in areas such as separation science and the development of new methodologies for heavy elements.

**Quantum dynamics** – A part of our group's efforts focuses on time-dependent quantum



*The spin density difference and the participating orbitals in a light-induced spin flip in FeCO determined using a newly developed time-dependent spin-*

*orbit coupling configuration approach from our group, designed to describe quantum dynamical phenomena.* (From *Phys. Chem. Chem. Phys.* **2019**, *21*, 7265; back cover article.)

mechanical approaches across the periodic table. Of particular interest in addition to our development of methodologies is the study of light-driven phenomena.

**Catalysis** – Homogeneous and heterogeneous catalysis are of interest, and we investigate a broad range of catalytic reactions, including novel electrocatalysts.

**Drug design/understanding disease and biological function** – We utilize a variety of computational chemistry approaches towards the understanding and design of potential pharmaceuticals for diseases including cancers and tuberculosis. We also investigate structure activity relationships, the role of signal transduction cascades in disease, and approaches to modulate biological functions.

**Environmental and sustainable chemistry** – We investigate the impact at the molecular level of contaminants such as CO<sub>2</sub> and PFAS compounds. For PFAS, the impact of the com-



*Per- and Polyfluoroalkyl Substances (PFAS) are prevalent in day-to-day products. Here, the interaction of some of the most prevalent PFAS with peroxisome proliferator-activated receptor gamma (PPAR $\gamma$ ), a nuclear receptor fundamental to the regulation of genes is considered.* (*ACS Omega*, 2021)

pounds on human and animal proteins and their absorption and transport in soil and water are of focus. Routes for possible mitigation are also considered. 🌱

My research efforts will mainly be on non-molecular inorganic materials involving almost the whole periodic table and diverse theories and methods to design, predict and synthesize new materials. We will work to answer three general questions: **1.** What are the chemical structures and physical properties of new metal-rich compounds? **2.** Why do they crystallize in their structure types and exhibit such physical properties? **3.** How does the structure influence physical properties? To address these problems,



powder and single crystal X-ray diffraction and neutron powder diffraction, if necessary, will be utilized to determine the crystal structure and phase information, in addition to magnetic and electrical conductivity measurements to be analyzed by a Quantum Design Physical Property Measurement System. With respect to theory, first-principle electronic structure calculations based on TB-LMTO-ASA, WIEN2k, and VASP packages will be employed to investigate patterns of atomic arrangements, structural phase transitions, magnetic ordering, superconductivity, and other properties.

### Critical Charge-Transfer Pairs and Electron Counting Rules for Superconductivity and Magnetism

– “Critical pairs” of atoms in the periodic table can be postulated where the balance between covalent and ionic bonding leads to just the right kind of charge transfer between the atoms so that the bond valence responds to perturbations from the other forces present to lead to instabilities in a compound’s electronic system that are delicately balanced with other factors such as electron-lattice coupling, magnetism or superconductivity. Well-known examples of such critical charge-transfer pairs in the periodic table are Cu-O and Fe-As, which lead to high-temperature superconducting properties. In contrast to the quantitative *k* space or Fermi surface view in physics, the concept of critical charge transfer pairs is clearly a qualitative, real space view of what can give rise to interesting physical properties. The design of new  $W_5Si_3$ -type superconductors  $T_5Sb_{3-x}Ru_x$  ( $T = \text{Hf, Zr}$ ) lead us to propose that Ru-Sb may be a third critical charge-transfer pair of elements for superconductivity in the periodic table along with Cu-O and Fe-As.

Moreover, based on our empirical theory- a fragmental formalism for making superconductors, we found that the superconductor  $\text{LaRu}_4\text{Sb}_{12}$  could be viewed as stuffing  $\text{RuSb}_6$  octahedra at  $(\frac{1}{4}, \frac{1}{4}, \frac{1}{4})$  site in *W*-type “La”. Similarly, another superconductor  $\text{Ca}_3\text{Rh}_4\text{Sn}_{13}$  can be considered as putting  $\text{RhSn}_6$  trigonal prisms at  $(\frac{1}{4}, \frac{1}{4}, \frac{1}{4})$  site in  $\text{Nb}_3\text{Ge}$ -type “ $\text{Ca}_3\text{Sn}$ ”.

Valence electron counting rules are favored by chemists because they can be useful to rationalize and predict the chemical behaviors of substances, for example, their structures and electrical properties. The Zintl-Klemm concept is such a valence electron counting scheme that has achieved wide usage among molecular and solid-state disciplines, similar to the octet (Lewis–Langmuir) rule applied to problems in organic, main-group inorganic, and biochemistry and the 18-electron counting rule for organometallic complexes.

Classical Zintl phases are considered to be valence precise semiconductors with electropositive cations (typically, Alkali and Alkali-earth or Rare-earth elements) donating their electrons to electronegative anions, which use electrons to form bonds in order to satisfy their valence. At the border between classical Zintl phases and normal metallic phases, for compounds called polar intermetallics, the semi-conducting band gap diminishes and metallic conductivity can result. These compounds can, for example, be made good thermoelectric materials. Moreover, a new series of superconductors, like  $\text{ReGa}_5$ , have been predicted and synthesized on the broader of Zintl phases with pseudo semiconducting band gap.

### Spin-Orbit Coupling (SOC) Effects on Magnetism in 4d/5d Transition Metal Halides

– The importance of spin-orbit coupling (SOC) to generate the electronic ground state in 4d/5d-based compounds has emerged and many novel routes to host unconventional physical states have been revealed, for example, quantum spin liquids, Weyl semimetals, and axion insulators. The major experimental and theoretical efforts in quantum spin-liquid state study have been solely undertaken to search for novel spin-orbit coupling systems in the various *d5* system with  $S = \frac{1}{2}$ , for example,  $\alpha\text{-RuCl}_3$ . Few references have been reported concerning other situations, for example,  $S = \frac{3}{2}$ , because octahedral *d3* configurations are expected to be orbitally quenched  $S = \frac{3}{2}$  states — in which case SOC enters only as a 3<sup>rd</sup> order perturbation. A common magnetic phenomenon related to SOC is spin-canting, which has been widely observed and investigated in many different systems. Spin-canting means spins are tilted a small angle about their axis rather than being accurately parallel. Generally, spin canting can be considered as a strong hint of large SOC in the different systems. We focus on the study of SOC on octahedral *d3* configurations with spin-canting.

### High-Pressure Single Crystal X-ray Diffraction on Solid State Materials

— Pressure provides a useful tool to precisely tune the interatomic distances in quantum materials, which is critical to understanding the organizing principles that govern electron dynamics with strong quantum fluctuations. We focus on the study of crystal structure and physical properties under high pressure. ●



Weiwei Xie

## Experimental and Theoretical Quantum Materials

ASSOCIATE PROFESSOR

B.S.,  
Nankai Univ. (Tianjin, China);

Ph.D.,  
Iowa State University;  
Postdoctoral Scholar,  
Princeton Univ.;

Assistant Prof.,  
Louisiana State Univ.;

Assistant Prof.,  
Rutgers Univ.;

517-355-9715



### SELECTED PUBLICATIONS

*The honeycomb and hyperhoneycomb polymorphs of  $\text{IrI}_3$* , D. Ni, K.P. Devlina, G. Cheng, X. Gui, W. Xie, N. Yao, R.J. Cava, *J. Solid State Chem.* **2022**, 312, 123240.

*$\text{Eu}_2\text{Mg}_2\text{Bi}_2$ : Competing Magnetic Orders on a Buckled Honeycomb Lattice*, M. Marshall, F. Wang, T. Klimczuk, R.S. Dissanayaka Mudiyanse, M. Greenblatt, D. Walker, and W.Xie, *Chem. Mater.* **2022**, 34, 9, 3902.

*Unusual Electrical and Magnetic Properties in Layered  $\text{EuZn}_2\text{As}_2$* , J. Blawat, M. Marshall, J. Singleton, E. Feng, H. Cao, W. Xie, R. Jin, *Adv. Quantum Technol.* **2022**, 2200012.

*Crystal Structure, Magnetism, and Electronic Properties of a Rare-Earth-Free Ferromagnet:  $\text{MnPt}_2\text{As}$* , Gui, X.; Xie, W., *Chem. Mater.* **2020**, 32, 9, 3922.

*Superconductivity in Metal-Rich Chalcogenide  $\text{Ta}_2\text{Se}$* , Gui, X., Górnicka, K., Chen, Q., Zhou, H., Klimczuk, T. Xie, W., *Inorg. Chem.* **2020**, 59(9), 5798.

*$\text{RuAl}_6$  – an endohedral aluminide superconductor*, Ryżyńska, Z., Chamorro, J.R., McQueen, T.M., Wiśniewski, P., Kaczorowski, D., Xie, W., Cava, R.J., Klimczuk, T., Winiarski, M.J., *Chem. Mater.* **2020**, 32, 9, 3805.

*Enhanced anomalous Hall effect in the magnetic topological semimetal  $\text{Co}_2\text{Sn}_2\text{In}_2\text{S}_2$* , Zhou, H., Chang, G., Wang, G., Gui, X., Xu, X., Yin, J.X., Guguchia, Z., Zhang, S.S., Chang, T.R., Lin, H. Xie, W., *Phys. Rev. B* **2020**, 101(12), 125121.

# ADMISSION

to graduate study begins when the Chemistry Department extends an offer of acceptance, which we routinely do to applicants from all around the world. Applying to our Graduate Program can easily be accomplished online at:

<http://www.chemistry.msu.edu/apply>

Incoming graduate students are expected to have the equivalent of a Bachelor's Degree in Chemistry, including at least one year of organic chemistry, one year of physical chemistry, at least one course in inorganic chemistry and at least one course in analytical chemistry/instrumental analysis — all at the undergraduate level. Minor deficiencies in these requirements may be remediated during the first year of the student's graduate program.

Each application for admission to the graduate program is considered individually by the faculty members on the Graduate Admissions Committee. Transcripts, three letters of recommendation, GRE scores (optional), TOEFL or IELTS scores for international students, and a statement of purpose are required of each applicant. Admission decisions are based on the apparent training, skills, experiences, and attitude

of the applicant, and the likelihood of a successful graduate career at MSU. Offers of acceptance are made to only a small fraction of the many applicants each year.

To begin the application process, please follow the Application Procedures which are listed on the Chemistry Department's website:

<http://www.chemistry.msu.edu/apply>

Submit the Applicant Datasheet and the University Application electronically, and arrange to have your three letters of recommendation, transcripts, official test scores, and statement of purpose mailed directly to the Chemistry Department Graduate Office.

After submitting your Applicant Datasheet, you may check your application status through our website

under Graduate Program, Check Application Status. Your Status Page will indicate what items have been received and what items are still missing, and will also give a short note at the end of the page concerning your general application status. Most applicants will receive a final decision on their application sometime between January and March, although some decisions are made before and after that time period. As soon as we have made a decision on your application, the decision will appear on your Status Page, and we will contact you through e-mail.

We hope that you will seriously consider choosing the Graduate Program in Chemistry at Michigan State University. Successful careers in Chemistry begin at MSU! 🍌



*Chemistry graduate students Xiaojing Shen and Rachele Lubeckyj from Professor Sun's group collaborate on performing an LC-mass spec experiment for their research.*

# MICHIGAN STATE UNIVERSITY

*was the country's first land-grant institution and was founded in*

*1855. The University was created with an initial focus on agriculture and farm science. When it was created, it established a new approach to education, research and public service. MSU is now the largest institution of higher learning in the state, with more than 200 programs of undergraduate and graduate studies in 19 colleges.*

## A Brief History of MSU

In 1855, the Michigan State Legislature passed Act 130 which provided for the establishment of the "Agricultural College of the State of Michigan," which came to be known as the Michigan Agricultural College or "MAC." They also appropriated "twenty-two sections of Salt Spring Lands for its support and maintenance...", as well as \$40,000 to carry the college through its first 2 years of operation. The MAC was formally opened and dedicated on May 13, 1857, in what is now East Lansing. MAC was the first agricultural college in the nation, and served as the prototype for the 72 land-grant institutions which were later established under the Federal Land Grant Act of 1862, unofficially known as the "Morrill Act" after its chief sponsor, Senator Justin Morrill of Vermont. The MAC's original tract of land in East Lansing consisted of 677 acres, but additional lands were purchased over the years as the MAC grew to become

Michigan State University. Presently MSU's campus and farms cover about 5,198 acres, of which about 2,100 acres are in existing or planned campus development.

## The Campus

The East Lansing campus of MSU is one of the most beautiful in the nation. Early campus architects designed it as a natural arboretum—a living laboratory—with 7,000 different species of trees, shrubs and vines represented. There are about 200 major buildings, 100 miles of walkways, and 12 miles of bicycle paths on campus. The campus is a unique blend of the traditional and the innovative. The Red Cedar River bisects the campus; north of the river's tree-lined banks and grassy slopes is the older, traditional heart of the campus. Some of the existing ivy-covered red-brick buildings found in this part of campus were built just after the Civil War. On the south side of the river are the more

recent additions to campus—the medical complex, the veterinary medical center, and most of the science and engineering buildings, including Chemistry. The National Superconducting Cyclotron Laboratory (NCSL) is also south of the river next to Chemistry and has recently completed a multimillion dollar upgrade to operate two cyclotrons in tandem, providing a wide range of heavy-ion beams, and includes a new office wing. This facility has received international recognition both for its active programs of basic research and for its pioneering innovations in cyclotron design. In addition, in 2010 MSU won a hotly-contested national competition to host the US-DOE Facility for Rare Isotope Beams (FRIB), a \$600M national user facility scheduled to begin construction in 2013 as an important extension to the NCSL.

Beyond the East Lansing campus of Michigan State University—about an hour's drive away—are our two natural

*MSU's Eli and Edythe Broad Art Museum is a contemporary museum devoted to the exploration and exhibition of significant works of art from around the globe.*



With a capacity of over 75,000, Spartan Stadium is home to the MSU Spartans football team, which had a very successful 2015-16 season culminating in winning the BIG 10 Championship and playing in the CFP Semifinal Cotton Bowl. They won the Big 10 in 2013-14 as well as the 100<sup>th</sup> Rose Bowl game against Stanford University. In 2014-15, they were ranked #5 in the nation and won the Cotton Bowl, defeating Baylor. Attending home games is a very popular pastime for many MSU students.



science research facilities: the Kellogg Biological Station at Gull Lake, and Hidden Lake Gardens near Tipton. The 2,200 acre Kellogg Biological Station is a bird sanctuary, experimental farm and research forest, and a national center for lake-and-land ecological research. Hidden Lake Gardens is a 670 acre landscape arboretum which serves as an outdoor classroom. Located in the Michigan Irish Hills, Hidden Lake features a conservatory complex containing collections of tropical, arid, and temperate plants from around the world. Both facilities are open to visitors all year.

### The Arts

The arts have flourished at MSU, especially in the past two decades after our impressive performing arts facility, the Wharton Center for Performing Arts, opened in the Fall of 1982. From the very beginning it has been the showcase for an extraordinarily broad array of performances in music, theater, and dance and popular shows. The Wharton Center's two large concert halls are regularly used for recitals, concerts and theater productions by faculty, student groups, and visiting and touring performing artists. The Center brings to our campus dozens of professional musical and theatrical productions each year, such as 2022-23 upcoming events like *Ballet Hispanico*, *Hades Town*, *Cats*, and *Disney's Frozen*,

and performers such as Leslie Odom, Jr., Kristin Chenoweth, and Rain—A Tribute to the Beatles.

In 1992, the Wharton Center was the site of one of the debates between U.S. Presidential hopefuls Bill Clinton, George H. Bush and H. Ross Perot. It's a short one-block walk from the Chemistry Building to the Wharton Center.

MSU is also home to the Jack Breslin Student Events Center, a 15,000+ seat arena which is home to the MSU Spartan basketball team, and also periodically plays host to world-class concerts and attractions.

A facility that offers both educational and recreational opportunities is the MSU Museum. The Museum houses documented research collections in Anthropology, Paleontology, Zoology and Folklife as well as regularly hosting traveling exhibits.

In addition, the [\*Eli and Edythe Broad Art Museum\*](#) is now a premier venue for international contemporary art in the Lansing area. The old Kresge Art Center's art collection has been combined with the Broad Museum; it was strongest in examples of 19<sup>th</sup> and 20<sup>th</sup> century art, but it also contains a wide variety of other artworks such as Egyptian sculpture of the Coptic Period, etchings by Rembrandt, and works by Salvador Dali, Ansel Adams, and Auguste Rodin.

### Recreational Opportunities

Many recreational activities are available on campus and in the Lansing area. Walking and running trails, available extensively throughout the campus, take you through protected natural areas along the Red Cedar River. MSU has two 18-hole golf courses available to students, faculty and staff. There are three fitness centers that provide basketball, handball and squash courts, exercise machine rooms, and aerobic workouts. Two indoor ice skating rinks, an indoor tennis facility, more than thirty outdoor tennis courts, and five swimming pools are accessible as well. In both summer and winter, nearby state parks such as Rose Lake and Sleepy Hollow offer many activities. In Michigan, snow is not a problem, but rather an activity, so bring your skis!

MSU, which was admitted to the Big Ten in 1948, has a rich tradition in athletics. MSU first competed in conference football in 1953, sharing the title that year with Illinois. Since that time, MSU has enjoyed considerable success in Division I athletics, including NCAA titles in basketball and hockey, among other sports. Graduate students, faculty, and staff in the Chemistry Department are strong supporters of the athletic programs, which offer ample opportunities for social interactions outside of the laboratory.





*Cobb Great Hall at the Wharton Center for Performing Arts at MSU seats over 2,400 guests, and is home to many Broadway plays, concerts, and comedy and dance performances each year. The Center also houses the Pasant Theatre (600 seats), the Fairchild Theatre (600 seats) and the MSU Concert Auditorium (3,600 seats). It opened in 1982, and was expanded and renovated in 2008.*

## Academics

There are over 50,500 students on campus—from all 83 counties in Michigan, all 50 U.S. states, and 138 foreign nations. Of these, approximately 11,400 are in graduate and professional programs. By gender, MSU is 51.5% women and 48.4% men. Michigan State leads all public universities in attracting National Merit Scholars, and is also a leader in the number of students who win National Science Foundation Fellowships. MSU was the first university to sponsor National Merit Scholarships.

The extensive MSU library system includes the main library and 5 branches. A total of over four million volumes are housed in these facilities. Across the street from Chemistry is the Abrams Planetarium, one of the most active planetariums in the world. It is used for teaching, and offers shows and exhibits to the general public.

If students are the lifeblood of a campus, then the faculty is the heart of a great university. The more than 5,000 MSU faculty and academic staff continue to distinguish themselves, and include 9 current members in the National Academy of Sciences, and honorees of prestigious fellowships such as the Fullbright, Guggenheim and Danforth.

The Chemistry Department and MSU continue to evolve, crossing traditional

research boundaries to offer teaching and research opportunities that will have an impact on the future of science. MSU is well known for its interdisciplinary research centers, which have an outstanding record for solving not only scientific problems, but social problems as well. These include the Department of Energy Plant Research Lab, The Center of Research Excellence in Complex Materials, the Institute for Integrative Toxicology, the A. H. Case Center for Computer-Aided Engineering and Manufacturing, the Mass Spectrometry Facility, the Center for Advanced Microscopy, the Institute of Water Research, the National Food and Safety Toxicology Center, the Center for Ethics and Humanities in the Life Sciences, and the Institute for Children, Youth and Families. The federal government has selected MSU's campus as the site for a number of facilities such as the National Superconducting Cyclotron Laboratory, the Plant Research Laboratory (a U.S. Department of Energy facility) and the USDA Avian Disease and Oncology Laboratory.

University-wide research has led to important developments throughout MSU's history. Early research led to agriculturally important vegetable hybrids, and the process for homogenization of milk. More recently, the world's widest-selling and most effective type of anti-cancer drugs (cisplatin and carboplatin) were

discovered in the Chemistry Department at MSU, and crop cultivars have been developed at MSU that can be used to produce biodegradable plastics.

## Housing

A variety of living accommodations is available to graduate students. One option is the Owen Graduate Center, which offers traditional furnished rooms, private telephones, and free broadband computer networking, with two rooms sharing an adjoining bathroom and shower. Housekeeping services are provided for all. The hall has recreational and laundry facilities and a cafeteria. Many incoming graduate students find Owen Graduate Center a good place to begin, and after a short period of time they get to know the surrounding area and then move off-campus. The Owen facility is only two blocks from the Chemistry Building.

A second on-campus option is the University apartment system. About 2,000 furnished one- and two-bedroom apartments are available on-campus, primarily intended for married students and their families. Also available now are [\*beautiful four bedroom on-campus University apartments\*](#) for students at 1855 Place.

The third option is, of course, off-campus housing. Many apartment complexes are available within a two-mile radius of



*Michigan State University was founded in 1855 by an Act of the Michigan State Legislature; this Act was subsequently used as the template for the federal "Morrill Act" which has provided for the funding of 72 land-grant institutions in other States across the U.S. As a result, this sign proudly proclaims our status as "The Pioneer Land Grant College".*

campus, some within a few blocks of the Chemistry Building. In the past, graduate students in Chemistry have also rented condominiums and houses — either alone or in small groups. The cost of living is very reasonable in the Lansing area, and houses can still be purchased with monthly mortgage payments that are competitive with apartment costs. This is why, each year, some students decide to buy a home in the area while they are in the graduate program. The surrounding communities are varied, and offer rural and small-town settings

as well as "big city" alternatives, without the usual congestion or pollution of a larger metropolis. MSU provides information on current off-campus housing listings to prospective students upon request.

For further information on MSU housing options for graduate students, you may call toll free 1-877-954-8366, or visit the University Housing web site at:

<http://liveon.msu.edu/>

For more information about life at MSU and in the greater Lansing area, please visit the MSU Graduate School home page at:

<http://grad.msu.edu/prospective/>



*The Breslin Student Events Center, home of the Spartans basketball team, has the capacity to accommodate over 16,000 fans. It also plays host to many MSU commencements, large concerts, monster truck rallies and the occasional circus.*

# LANSING, MICHIGAN'S CAPITAL,

*is centrally located in Michigan's lower*

*peninsula. The greater metropolitan area has a population of approximately 470,000, and is home to several large industries. The city offers a variety of restaurants, the Lansing Symphony Orchestra, a number of theater companies, and the Lansing Lugnuts. The Impression 5 Science Museum, the R. E. Olds Transportation Museum, and the Michigan Historical Museum attract visitors from throughout the region. Major local employers include MSU, the Michigan state government, and General Motors. Several high-tech companies are located in the area, including the Michigan Biotechnology Institute, Emergent Biosolutions, Niowave, and Neogen Corporation.*

There is a large scientific community in the Lansing area which, along with MSU, is owing in part to the presence of a number of the State of Michigan research laboratories in the area, including the Department of Agriculture, the Department of Natural Resources and Environment, the Department of Public Health Laboratories, and the Michigan State Police Crime Laboratories. In addition to MSU, Lansing Community College, the Thomas M. Cooley Law School, and Davenport College are all located in the capital city area, and the MSU College of Law is housed on the MSU campus.

It's only a short distance to a number of other Michigan cities that are scientific, educational and cultural centers as well. For example, Kalamazoo, which lies about 80 miles to the southwest, is the home of Western Michigan University and Kalamazoo College (a premiere liberal arts institution). Chemists at MSU also interact with scientists at the University of Michigan and Pfizer (formerly both Warner-Lambert and Pharmacia & Upjohn) in Ann Arbor,

and a number of other research laboratories in the state, including Dow Chemical (Midland, MI), General Motors (Detroit), Ford (Dearborn, MI), and BASF (Wyandotte, MI).

Situated in the heart of the Great Lakes region of the U.S., MSU's East Lansing Campus is centrally located not only to metropolitan areas such as Chicago and Detroit, but to outstanding natural resources and to northern Michigan's world-class summer and winter resorts. Michigan's Upper Peninsula is a relatively undeveloped and unspoiled area of immense natural beauty with a population density of less than twenty persons per square mile. It offers many unique "get-away" opportunities for all seasons. The Lansing area itself provides a variety of recreational opportunities including many golf courses, boating and beach life at Lake Lansing in the summer, and cross-country skiing in the winter. Hunting and fishing opportunities are also found widely throughout the state.

The Lansing area has outstanding transportation facilities. Lansing has an award-winning bus system (CATA) which operates both dedicated campus-only bus routes and routes that connect campus with metropolitan Lansing. Bicycles are a common mode of transportation in the area. Several miles of special bike paths are provided on campus which stretch into outlying towns. Transportation to other cities is also available by air, rail and bus. The Capital City Airport in Lansing and the Amtrak railroad station in East Lansing are both readily accessible from MSU. East Lansing is a stop on the train line that links Chicago to Toronto, Canada.

Complementing campus life is the city of East Lansing, which surrounds the northern edge of the MSU campus. East Lansing is noted for its congenial atmosphere and tree-lined avenues. Shops, restaurants, bookstores, cafés, malls and places of worship serve the student's needs. East Lansing provides students with a relaxing and stimulating environment for their graduate school experience. 🌿



## IN CLOSING...

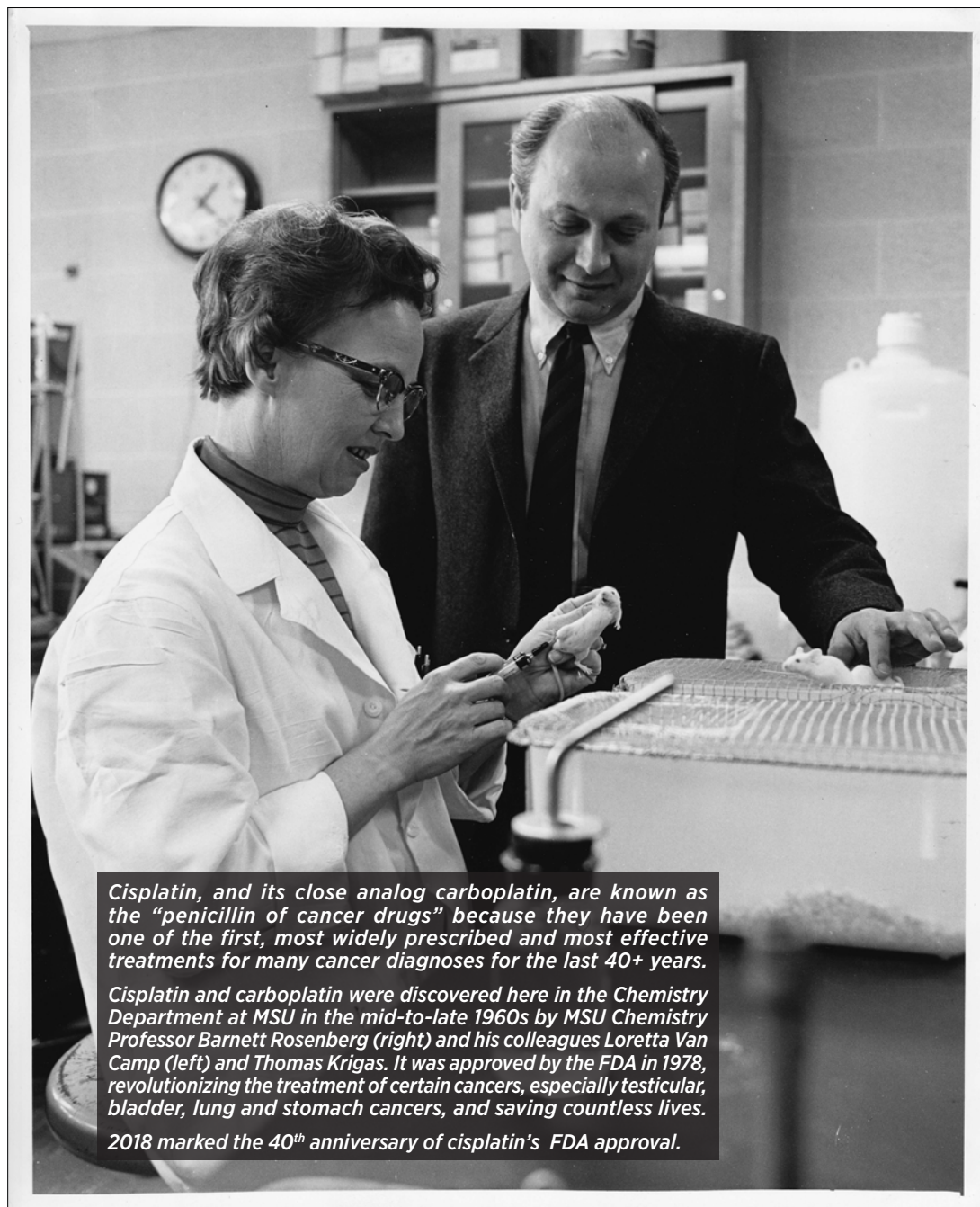
The State of Michigan, Michigan State University, and the MSU Chemistry Department have a common component to their histories — they have played important roles in defining a vision for the future. At the state level, the automobile industry established a new model for industries around the country. As the pioneer land grant university, MSU was dedicated to the discovery and application of knowledge. From the very beginning, the faculty were expected to engage in research that resulted in the acquisition of new knowledge, and to use this new knowledge to improve the quality of life for the citizens of the state and the world. This tradition of scientific research at MSU is frequently traced back to 1877, when MSU botanist William J. Beal became the first person to cross-fertilize corn, leading to today's vastly improved cultivars and hybrids which produce greatly increased yields.

When MSU was founded as Michigan Agricultural College in 1855, it dared to develop a chemistry curriculum. At the time, major U.S. universities emphasized the study of Greek, Latin, rhetoric, and philosophy. Not only did MSU develop a program in chemistry, it did so in an innovative way — approaching the discipline not as a static science to be taught in classrooms, but as an experimental discipline in which concepts are discovered and tested through creative thought and research.

Today in the USA, many universities compete for grants from federal and private sources to support academic research. MSU competes very effectively

in this endeavor. Each year, the number of proposals submitted by MSU faculty increases, leading to corresponding increases in federal research money on campus. The university faculty have made a permanent commitment to maintain a strong graduate program at MSU, and funding agencies have come to recognize MSU's research programs as good investments. The State, the University, and the Chemistry Department continue to be dynamic

forces which are defining aspects of the country and the role of Universities for the foreseeable future. We hope that you share our excitement, and will consider becoming a part of it! 🍀



*Cisplatin, and its close analog carboplatin, are known as the "penicillin of cancer drugs" because they have been one of the first, most widely prescribed and most effective treatments for many cancer diagnoses for the last 40+ years.*

*Cisplatin and carboplatin were discovered here in the Chemistry Department at MSU in the mid-to-late 1960s by MSU Chemistry Professor Barnett Rosenberg (right) and his colleagues Loretta Van Camp (left) and Thomas Krigas. It was approved by the FDA in 1978, revolutionizing the treatment of certain cancers, especially testicular, bladder, lung and stomach cancers, and saving countless lives.*

*2018 marked the 40<sup>th</sup> anniversary of cisplatin's FDA approval.*

# NOTES

# The Periodic Table of the Elements

1	2	3	4	5	6	7	8	9	10	11	12	13	14	15	16	17	18																																																											
1 <b>H</b> HYDROGEN 1.008	2 <b>He</b> HELIUM 4.003	3 <b>Li</b> LITHIUM 6.941	4 <b>Be</b> BERYLLIUM 9.012	5 <b>Na</b> SODIUM 22.989	6 <b>Mg</b> MAGNESIUM 24.305	7 <b>K</b> POTASSIUM 39.098	8 <b>Ca</b> CALCIUM 40.078	9 <b>Sc</b> SCANDIUM 44.955	10 <b>Ti</b> TITANIUM 47.867	11 <b>V</b> VANADIUM 50.941	12 <b>Cr</b> CHROMIUM 51.996	13 <b>Mn</b> MANGANESE 54.938	14 <b>Fe</b> IRON 55.845	15 <b>Co</b> COBALT 58.933	16 <b>Ni</b> NICKEL 58.693	17 <b>Cu</b> COPPER 63.546	18 <b>Zn</b> ZINC 65.39	19 <b>Ga</b> GALLIUM 69.723	20 <b>Ge</b> GERMANIUM 72.61	21 <b>As</b> ARSENIC 74.922	22 <b>Se</b> SELENIUM 78.96	23 <b>Br</b> BROMINE 79.904	24 <b>Kr</b> KRYPTON 83.80	25 <b>Rb</b> RUBIDIUM 85.467	26 <b>Sr</b> STRONTIUM 87.62	27 <b>Y</b> YTTORIUM 88.905	28 <b>Zr</b> ZIRCONIUM 91.224	29 <b>Nb</b> NIOBIUM 92.906	30 <b>Mo</b> MOLYBDENUM 95.94	31 <b>Tc</b> TECHNETIUM (98)	32 <b>Ru</b> RUTHENIUM 101.07	33 <b>Rh</b> RHODIUM 102.91	34 <b>Pd</b> PALLADIUM 106.42	35 <b>Ag</b> SILVER 107.87	36 <b>Cd</b> CADMIUM 112.41	37 <b>In</b> INDIUM 114.82	38 <b>Sn</b> TIN 118.71	39 <b>Pb</b> LEAD 207.2	40 <b>Tl</b> THALLIUM 204.38	41 <b>Po</b> POLONIUM (209)	42 <b>At</b> ASTATINE (210)	43 <b>Rn</b> RADON (222)	44 <b>Fr</b> FRANCIUM (223)	45 <b>Ra</b> RADIUM (226)	46 <b>Cs</b> CESIUM 132.91	47 <b>Ba</b> BARIUM 137.33	48 <b>La</b> LANTHANIDES	49 <b>Ce</b> CERIUM 140.12	50 <b>Pr</b> PRASEODYMIUM 140.91	51 <b>Nd</b> NEODYMIUM 144.24	52 <b>Pm</b> PROMETHIUM (145)	53 <b>Sm</b> SAMARIUM 150.36	54 <b>Eu</b> EUROPIUM 151.96	55 <b>Gd</b> GADOLINIUM 157.25	56 <b>Tb</b> TERBIUM 158.93	57 <b>Dy</b> DYSPROSIUM 162.50	58 <b>Ho</b> HOLIUM 164.93	59 <b>Er</b> ERBIUM 167.26	60 <b>Tm</b> THULIUM 168.93	61 <b>Yb</b> YTTERIUM 173.04	62 <b>Lu</b> LUTETIUM 174.97	63 <b>Ac</b> ACTINIDES (227)	64 <b>Th</b> THORIUM 232.04	65 <b>Pa</b> PROTACTINIUM 231.04	66 <b>U</b> URANIUM 238.03	67 <b>Np</b> NEPTUNIUM (237)	68 <b>Pu</b> PLUTONIUM (244)	69 <b>Am</b> AMERICIUM (243)	70 <b>Cm</b> CURIUM (247)	71 <b>Bk</b> BERKELIUM (247)	72 <b>Cf</b> CALIFORNIUM (251)	73 <b>Es</b> EINSTEINIUM (252)	74 <b>Fm</b> FERMIUM (257)	75 <b>Md</b> MENDELEVIUM (258)	76 <b>No</b> NOBELIUM (259)	77 <b>Lr</b> LAWRENCIUM (262)

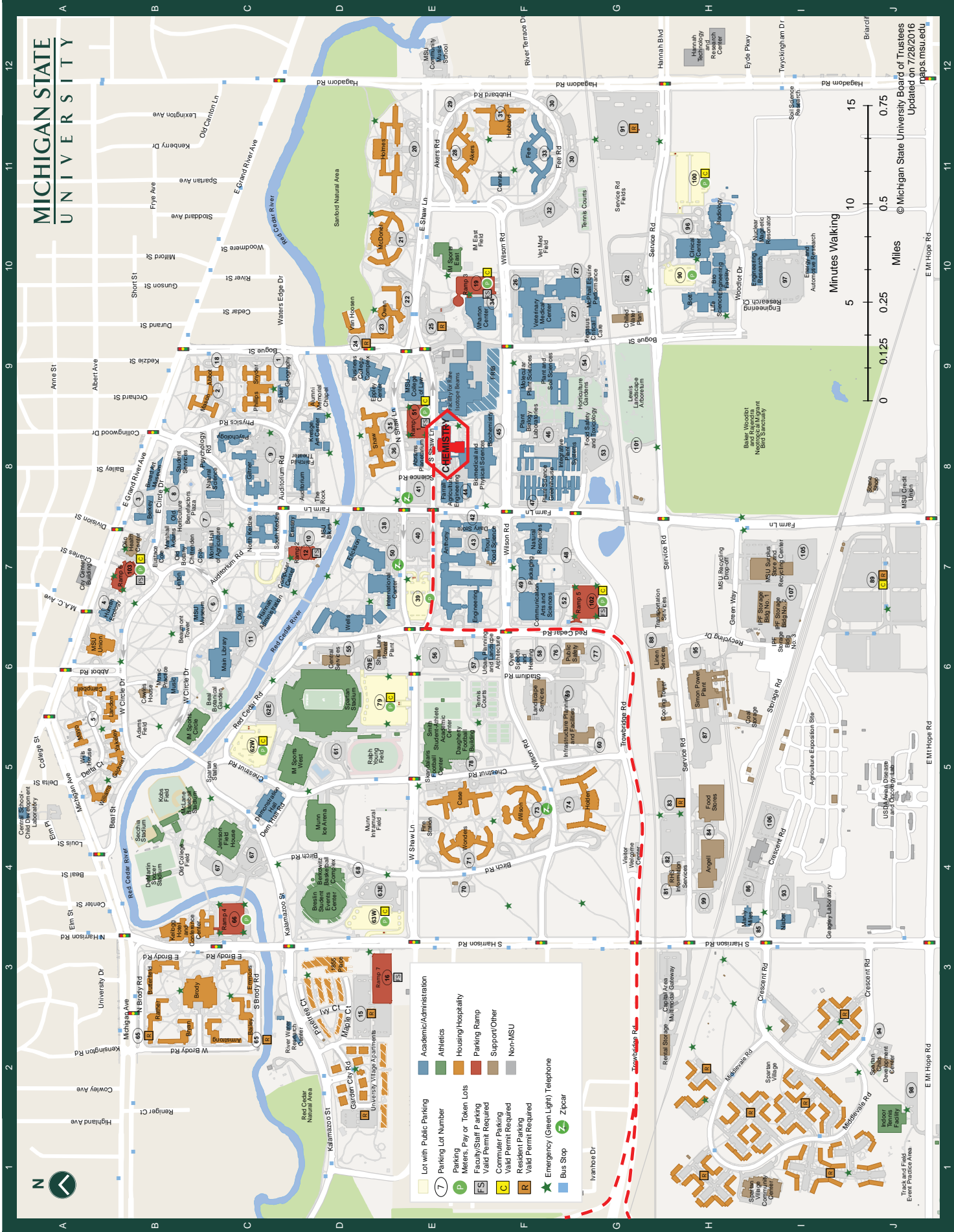
- Alkali Metals
- Alkaline Earth Metals
- Transition Metals
- Lanthanide Series
- Actinide Series
- Other Metals
- Nonmetals
- Noble Gases

**C** Solids **He** Gases  
**Br** Liquids **Tc** No stable isotopes

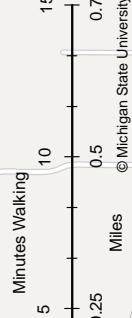
LANTHANIDES

ACTINIDES

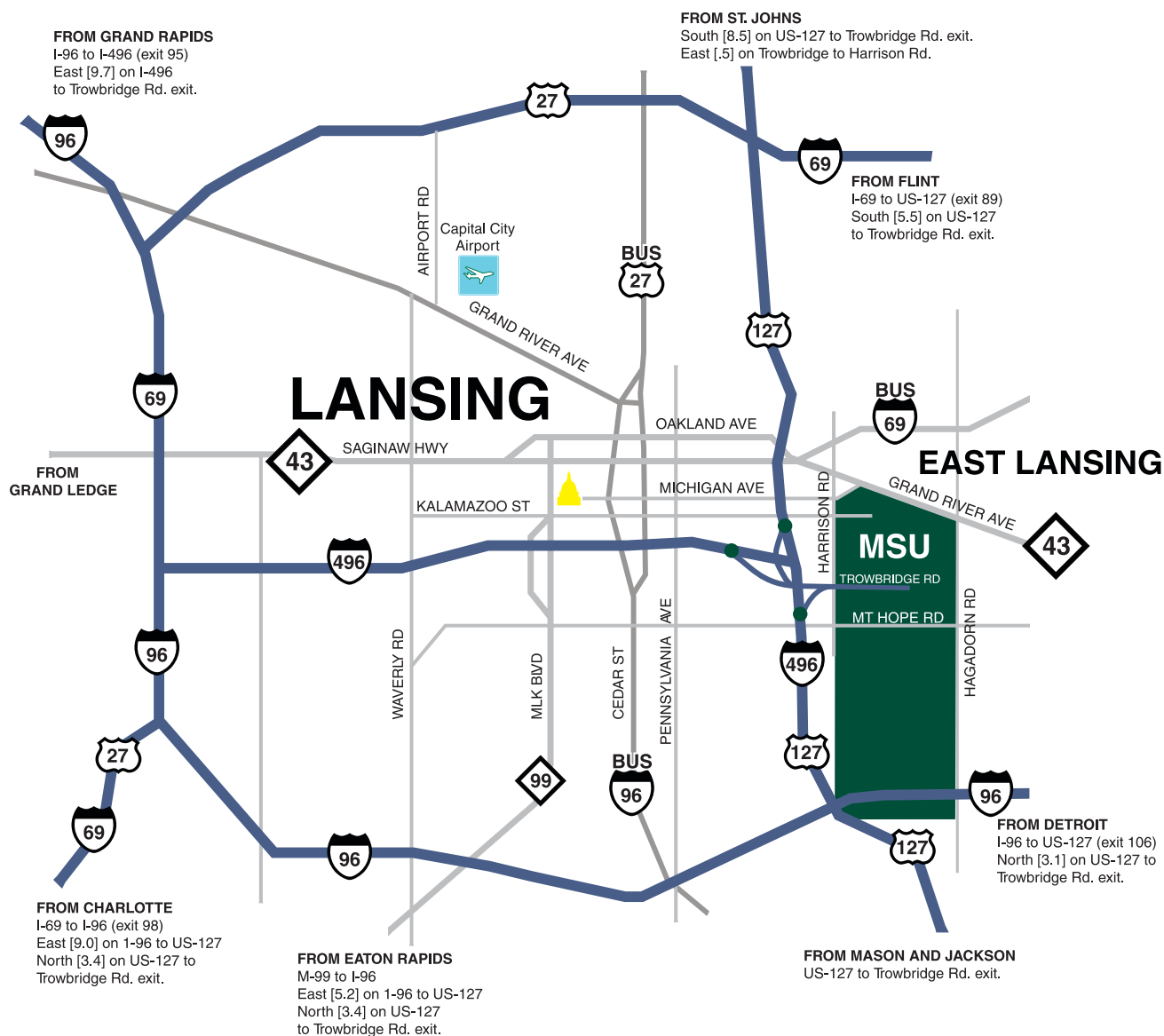
# MICHIGAN STATE UNIVERSITY



- Lot with Public Parking
- 7 Parking Lot Number
- Parking
- Maters, Pay or Token Lots
- Faculty/Staff Parking
- Valid Permit Required
- Computer Parking
- Valid Permit Required
- Resident Parking
- Valid Permit Required
- ★ Emergency (Green Light) Telephone
- Bus Stop
- Z Zipcar
- Academic/Administration
- Athletics
- Housing/Hospitality
- Parking Ramp
- Support/Other
- Non-MSU



© Michigan State University Board of Trustees  
 Updated on 7/28/2016  
[maps.msu.edu](http://maps.msu.edu)



Visit our website:  
[www.chemistry.msu.edu](http://www.chemistry.msu.edu)

